

Cohesive Smart Agriculture Services Management



Thesis Submitted to

The Superior College, Lahore

In Partial fulfillment of the

Requirement for the Degree of

Master of Philosophy in Information Technology

By

Farrukh Munir

MSIT-S17-001

SESSION: 2017-19

The Superior College (Department of Computer Sciences), Lahore

March-2019

Cohesive Smart Agriculture Services Management

By

Farrukh Munir

MSIT-S17-001

SESSION: 2017-19

Thesis Submitted to

The Superior College, Lahore

In partial fulfillment of the

Requirements for the degree of

Master of Philosophy in Information Technology

Approved By:

Dr. Usman Hashmi

Program Manager, Research Degrees

Dr. S. Khuram Shahzad

Research Supervisor

Mr. Muhammad Haris

Controller Examination

Thesis Submitted to



The Superior College

Department of Computer science, Lahore, Pakistan

**DECLARATION TO BE FILLED BY THE STUDENT AT THE TIME
OF SUBMISSION OF THESIS TO THE SUPERVISOR AND/OR FOR
EXTERNAL EVALUATION**

Section 1: Particular of the Student		
1.1	Full Name	Farrukh Munir
1.2	Father's Name	Muhammad Munir
1.3	Roll. Number	MSIT-S17-001
1.4	Program	Master of Philosophy in Information Technology

Section 2: Particular of the Thesis		
2.1	Title	Cohesive Smart Agriculture Services Management
2.2	Supervisor's Name	Dr. S. Khuram Shahzad
2.3	Date of Completion	23 March 2019



The Superior College

Department of Computer Science, Lahore, Pakistan

SUPERVISOR'S CERTIFICATE ON

THESIS SUBMITTED BY A STUDENT

Section 1: Particulars of the Supervisor		
1.1	Full Name	Dr. S. Khuram Shahzad
1.2	Address	The Superior College, Department of computer science, Lahore.

Section 2: Particulars of the Student		
2.1	Full Name	Farrukh Munir
2.2	Father's Name	Muhammad Munir
2.3	Registration Number	MSIT-S17-001
2.4	Program	Master of Philosophy in Information Technology

Section 3: Particulars of the Thesis		
3.1	Title	Cohesive Smart Agriculture Services Management
3.2	Date of Completion	23 March 2019

I certify that:

- The above-named student has completed the cited thesis under my guidance and supervision.
- I am satisfied with quality of the student's research work, and
- I consider it worthy of submission for external evaluation.

4.1	Supervisor's Full Signature	
4.2	Date	24-3-2019

Declaration of Originality

I **Farrukh Munir** hereby solemnly declare that this project:

- a) is my original work, except where otherwise acknowledged in the text?
- b) has not been published earlier and
- c) shall not be submitted by me in future for obtaining any degree from this or other university or institution
- d) has been incorporated HEC Plagiarism Policy
- e) In case of violation of HEC Plagiarism Policy, I shall be liable to punishable action under the plagiarism rules of HEC.

1	Student's Full Signature	
2	Date	

Dedication

This work is dedicated to my beloved Parents, my family and my respected teachers who inspired me for this research. They supported me throughout during my research and encouraged me to help achieve this goal. Thanks to all for their prayers and well wishes.



Acknowledgement

I am very grateful to Allah, who gave me the encouragement and willingness to do my best for this research. I obediently thank my respected teacher Dr. S. Khuram Shahzad. Not only did he provide support and guideline during this research, but he also provided valuable information, material and his time during the entire research. This project completed only due to his input and guidance. In addition, He also provided me valuable advice during the entire work. I am also thankful to Dr. Usman Hashmi. He really acts as a nice administrator and always guided me very positively during all stages of this thesis. I also acknowledge the support of Mr. Abdul Hameed our Program Coordinator.

Farrukh Munir

MSIT-S17-001



Abstract

Technology plays an important role in our everyday life. There has been a heavy demand of Internet of Things (IoT) in many sectors, which has drawn important research attention from both the academia and the industry. Smart agriculture is used to denote the application of IoT solutions in the area of agriculture. Precision Agriculture attaches smart devices to farmers like machines, soils, animals, climate, sensors etc. There are numerous smart agriculture services include, moisture sensing, spraying pesticides, Livestock monitoring, irrigation control, Water monitoring, Illumination control, Pest control etc. These Applications are working as individual services and the need of the hour is to provide a management platform where all these services work as a single unit providing all these facilities to the users.

Keywords: Internet of things (IoT), Smart Agriculture, Precision Farming, Drones, Sensors, Smart irrigation, Smart harvesting, Smart robots, Ploughing and seeding through IoT.

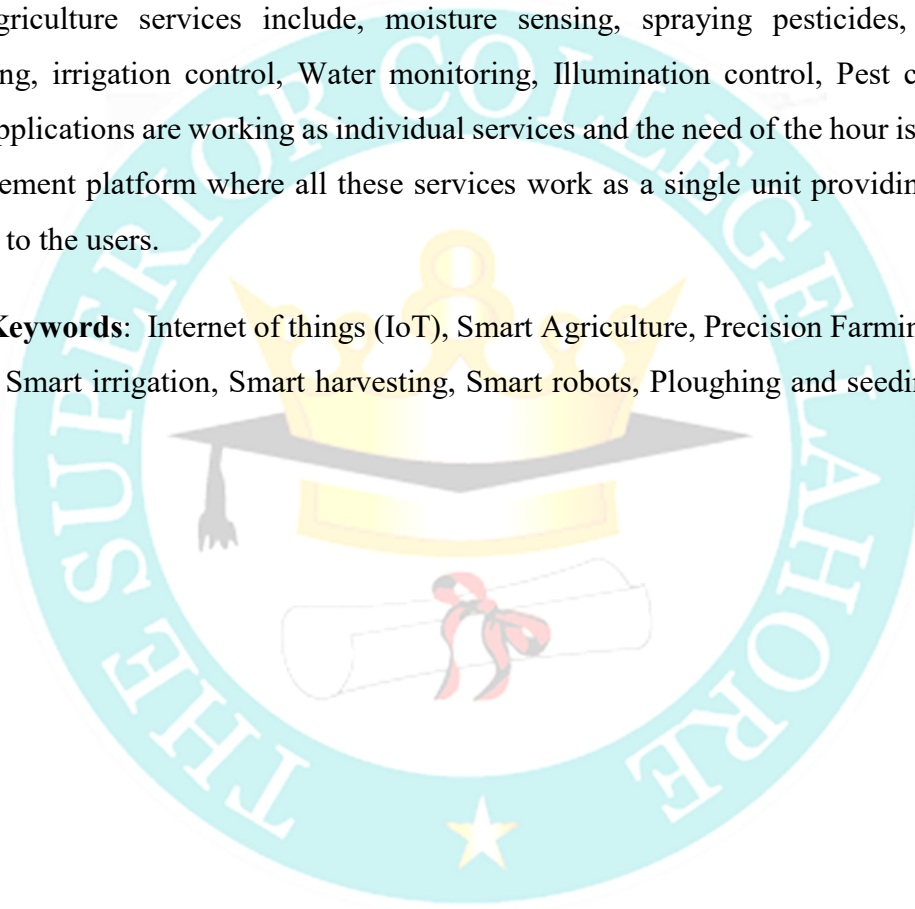

Table of Contents

Chapter 1 Introduction	13
1.1 Background.....	14
1.2 Problem Statement.....	15
1.3 Research Questions.....	15
1.4 Motivation of Research.....	16
1.5 Research Objectives.....	17
Chapter 2 Literature Review	18
2.1 Application of IoT in Agriculture.....	23
2.1.1 Disease Based Application.....	23
2.1.2 Monitoring.....	28
2.1.3 Soil Monitoring.....	34
2.1.4 Irrigation Monitoring.....	38
2.2 Ontology & Semantic Framework.....	41
Chapter 3 Methodology.....	44
3.1 Introduction.....	45
3.2 System Analysis.....	45
3.3 Competency Questions	46
3.4 Ontology Engineering.....	47
3.4.1 Requirement Analysis	47
3.4.2 Use cases	48
3.5 Glossary for Ontology	49
3.6 Vocabulary Building.....	50
3.7 Taxonomy Building	56

3.8 Semantic Relations	63
3.9 Constraints	66
Chapter 4 Experimentation & Results.....	67
4.1 Instantiation	68
4.2 SPARQL Based Validation	69
4.3 Reasoner based Validation.....	75
4.4 Conclusion and Future Directions	76
Chapter 5 References	78

List of Figures

Figure 2-1 Internet of Things (IoT).....	19
Figure 2-2 IoT Application Domain.....	21
Figure 2-3 Smart Agriculture	22
Figure 2-4 Vineyard Monitoring System.....	23
Figure 2-5 Weather and Forecast and Control System.....	25
Figure 2-6 Diagram of Intelligent Fertilizer and Pesticides	26
Figure 2-7 Agricultural disease and insect pest disasters information monitoring system.....	27
Figure 2-8 Structure of Monitoring Plant Disease and Insects Pests	27
Figure 2-9 Bock Diagram of Monitoring System.....	28
Figure 2-10 Block Diagram of AAFAMS.....	30
Figure 2-11 System Design	31
Figure 2-12 CPS	32
Figure 2-12 Four-layer architecture of IoT, WSN, M2M and CPS.....	33
Figure 2-14 Image Processing	33

Figure 2-15 Image Processing with help of IoT	34
Figure 2-16 Firmware Flowchart.....	35
Figure 2-17 Software Architecture of Citrus Soil and Humidity Monitoring System	36
Figure 2-18 System Architecture.....	37
Figure 2-19 Mobile Automated Irrigation.....	38
Figure 2-20 Automated Irrigation.....	39
Figure 2-21 Diagram	40
Figure 3-1 Taxonomy and Semantic Relation of Service Class.....	57
Figure 3-2 Taxonomy & Semantic Monitoring Service class	58
Figure 3-3 Taxonomy & Semantic Disease Service class.....	58
Figure 3-4 Taxonomy & Semantic Harvesting Service class.....	59
Figure 3-5 Taxonomy & Semantic Irrigation Service class	59
Figure 3-6 Taxonomy & Semantic relations of Activities	60
Figure 3-7 Taxonomy & Semantic Relation of Observation Class.....	61
Figure 3-8 Taxonomy & Semantic Relation of Actor Class	62
Figure 3-9 Taxonomy & Semantic Relation of Field Class	62
Figure 3-10 Semantic Relation of Service and System	63
Figure 3-11 Semantic Relation of Service and Activities	64
Figure 3-12 Semantic Relation of Activities and Actors.....	64
Figure 3-13 Semantic Relation of Observation and Activities.....	65
Figure 3-14 Semantic Relation of Observation and Activities.....	65
Figure 3-15 Semantic Relation of Observation and Activities.....	66
Figure 4-1 SPARQL Query of Use case 1.....	69

Figure 4-2 SPARQL Query of Use case 2..... 70

Figure 4-3 SPARQL Query of Use case 3..... 71

Figure 4-4 SPARQL Query of Automated Irrigation Service..... 72

Figure 4-5 SPARQL Query of DiseaseAndPestPerdictionService 73

Figure 4-6 SPARQL Query of Moisture 74

Figure 4-7 SPARQL Query of Robot..... 75



Chapter 1 **Introduction**



Internet of Things (IoT) is an important communication advancement in current time that joins the internet with everyday working devices and sensors with an IP based architecture. These electronic devices interconnect through wireless or wired channels to exchange and gather data. The numerous interdisciplinary applications of IoT includes smart cities, smart healthcare, automation in agriculture, industries, transportation where decision making is very difficult. Sensing objects and devices in internet of things sense and gather related information which later on can be analyzed, processes for healthier decision making [1].Internet of things allows physical objects in real-world to attach together to deliver computation based performance.

1.1 Background

The Internet of things in the last decade carried uncountable paybacks to organization and citizens all around Globe. Maybe most significant benefits were an ability to produce and consume data and services in actual period. IoT applications bring that same benefits to everyday objects, giving a way to spread awareness and ability to change environment around us [2]. Environmental fields and Agriculture are ideal for the implementation of Internet of things solution because that happen in wide ranged areas that need to be continuously controlled and monitored. Internet of things can be used at different points in the farming production chain. It can help to assess field variables such as soil state, atmospheric conditions and biomass of plants or animals. It can also be used to evaluate and control variables such as temperature, vibration, humidity and shock during the transport of products. [3]

The IoT smeared to the agriculture can donate a connected, informed, adaptable and developed rural area. Under the umbrella of Internet of things cheap electronic devices can better the human relations with all around the world. Software and computing power are available on Internet can provide valued analytics [4]. Internet of things is an important tool in the recent years to come for people interrelating within an agriculture system: farmers, distributors, suppliers, business, technicians, consumers and government officials. Internet of things can be combined with environmental applications to produce impenetrable and real time maps of water and air pollution, temperature, harmful radiation and noise level among

others. It is needed to incorporate different smart agriculture services in one solution. There is no such existing management architecture which can handle different smart agriculture service as a single architecture in the literature.

1.2 Problem Statement

- Current Solution are based on either
 - Service Functions/activities
 - Disease
 - Resources
 - Management
- Disjoint Solutions
 - Lacking Communication & data Sharing
 - Lacking Interoperability
- Heterogeneity
 - SOP
 - Architecture

1.3 Research Questions

Q1: What are the commonalities and differences among smart agriculture service architecture?

Q2: What are the commonalities and differences among smart agriculture service process model?

Q3: How can the standardization of common smart agriculture service architecture and process model be achieved?

Q4: How the Integration of different Smart agriculture service will be possible?

- H_0 : We cannot develop a cohesive smart agriculture services management architecture.
- H_1 : Develop a cohesive smart agriculture services management architecture

1.4 Motivation of Research

Many research organizations present viewpoints and trends for the future of Internet of things. International Data Corporation (IDC) guesses that IoT will reach about a US\$ 1.7 trillion market by 2020. Gartner predict that 25 billion associated devices by 2020. Cisco mentions around about 50 billion. Harvard Business Review thinks 28 billion devices connected to the Internet [5]. With the increasing adoption of the IoT linked devices have penetrated each aspect of life like fitness and health, automotive, logistics and home automation, smart cities and industrial internet of things. Thus, it is logical that Internet of things, connected devices and automation will find application in agriculture and vastly improve many facts of the agriculture practice. Now a days how someone rely on plows and horses when virtual reality and self-driving cars are no longer a science fantasy but an everyday incidence?

On the other hand, smart agriculture is typically used to provide the application of Internet of things solutions in farming.

This is a trend to use information technology for the development of modern agriculture. According to FAO, to feed the world's growing population, the world will need to produce more than 70% of the foods in 2050. For the fullness of demand agricultural companies and farmers are move towards the (IoT)Internet of Things for analytics and large production capabilities. The rapidly growing network of IOT linked items is meant to collect and exchange data using embedded sensors. The Internet of things is set to change the future of agriculture to the advance level. IoT technology mixes a variation of technologies such as automations, sensor, computer, telecommunications, RFID with agricultural machinery, Bio systems engineering, agricultural products supply chain management, animal, food science plants and soil science [3]

The market is still very dynamic, although smart agriculture as well as smart industrial are not as famous as consumer connected devices. Adoption of Internet of things solutions for farming is continuously growing. BI Intelligence predict about the number of smart agricultures IoT devices installations in 2020 will be 75 million. Growing rate is 20% per year. Global agriculture IoT market is probable to three time in 2025 at the same time, reaching \$15.3 billion related to being little'll over \$5 billion back in 2016. (**Reference4**)

Because the market is still developing, there are still plenty of opportunities for the businesses ready to join. In the coming years, building iot products for agriculture can be separated as early adoption and thus will help you to succeed.

1.5 Research Objectives

The aim is to provide all IoT based Smart Agriculture Services in smart environment under single management flow. Management of agriculture services will increase the cultivation quality and decrease the farming cost.

The objectives of this research are as follows:

- Exploring the commonalities and differences among smart agriculture service architecture
- Exploring the commonalities and differences among smart agriculture service process model
- The standardization of common smart agriculture service architecture and process model
- Integration of different Smart agriculture service
- Making sure the interoperability and standardization in the proposed integrated solution

Chapter 2 **Literature**

Review



The term IoT (Internet of Things) was first devised by Kevin Ashton in 1999.

The term 'Internet of Things' define as electronic devices of various sizes and capabilities which are connected to the Internet. The scope of connection capacity is only extended from machine to machine communication (M2M). internet of things devices deploys a wide array of applications, network domain and networking protocols the rising majority of internet of things technology various types of short-term wireless technologies are provided by the internet-related physical objects such as RFID, Zig-Bee, sensor, networks and through location based technology [6]. Internet of things make an effect of the Internet even more common, personal and daily life. According to Cisco Business Solutions the appearance of internet of things as a unique entity was attained, when many inorganic objects were linked to Internet than human users. According to this definition this is an accelerating continuing procedure with the rollout of Cisco Planetary Skin, intelligent vehicles and Smart Grid. [5]

Internet of things devices are not presently powerfully standardized in how they are linked with the Internet separately from their networking protocols. Internet of things working with additional security and management topographies to join for example, home environment management systems, vehicle electronics, telephonic networks and domestic utility services. The large scope of internet of things and how it can be used to linked different dissimilar networks is shown in Figure 2-1. [5]

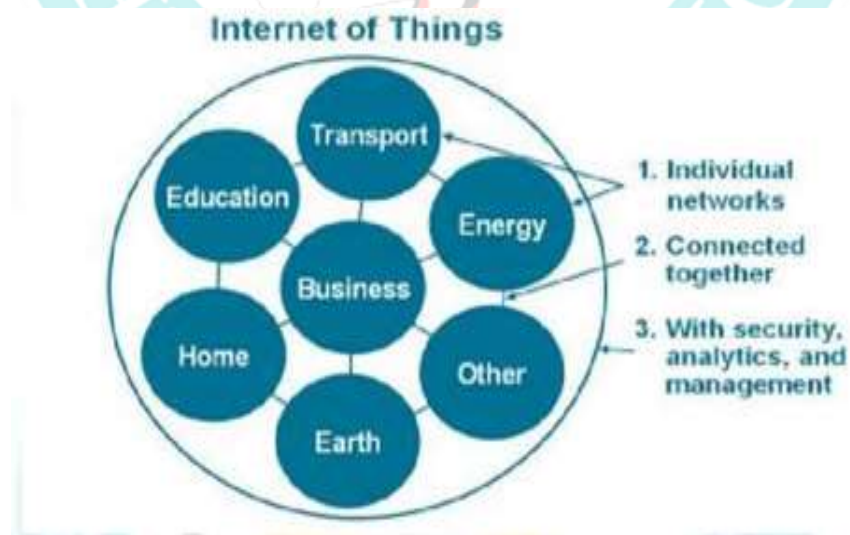

Figure 2-1 Internet of Things (IoT)

Probable applications of the Internet of things are several and different, soaking into basically all areas of everyday life of enterprises, society and individuals.

IoT is used in remotely handling different electronic appliances to save energy. Refrigerators having display screens showing what's inside and expiry of food. Alarms are generated on the smartphones to buy the vegetables and fruits that are going to be finished soon. Smart washing machines allow monitoring the laundry from anywhere anytime, and. Kitchen ranges like microwave oven can be handled using smartphone app as well. Outside weather conditions such as temperature, humidity, wind speed, pressure and rain levels can be seen using IoT.

Internet of things is also used in the arena of Transportation. Using smart roads can be built that warns the smart vehicles moving on the roads to avoid the travel during unwanted conditions like heavy snowfall or thunderstorms and it can also help people to avoid going to those roads where there is heavy traffic blockage. Smart Parking can also be enabled using IoT in which availability of parking spaces in the city can be monitored and the make populaces able to find and reserve the nearby obtainable spaces.

IoT in industry also plays a vital role. Explosive and Hazardous Gases can be detected using IoT enabled sensors. Gas levels and leakages can be monitored in industry. Monitoring of toxic gas and oxygen levels can help in securing the health safety for the workers in the industries.

Maintenance and repair of the equipment can be made easy using IoT due to early forecasts on equipment breakdowns and maintenance by services can be spontaneously planned ahead of a real part failure by planting sensors in the equipment to be monitored.

Internet of Things also influences the field of agriculture. Green Houses are maintained using IoT to controls climate conditions to increase the production of vegetables and fruits and it's also used for betterment of the quality. Temperature and humidity levels are monitored in different crops like hay, alfalfa, straw, etc. to avoid fungus and bacterial pollutants. Farming related animals is also one of the subcategories of Smart Agriculture in which location and identification of animals eating in open area in big strings are observed. Smart control of

rising conditions in animal farms is carried out to safeguard its health and survival, IoT also enable us to maintain a smart environment around us. Air Pollution monitoring can be done using IoT in which Carbon Dioxide emissions of factories can be controlled. Pollution released by vehicles and toxic gases produced in farms can be detected. Jungle Fire Detection can be smartly handled using IoT such as monitoring of burning gases and anticipatory fire conditions to generate alarming message. Weather monitoring can also be done in which weather conditions such as temperature, humidity, windspeed, pressure and rain are monitored. Any natural disaster can be anticipated using IoT techniques for example Earthquake Pre-detection is also possible by implanting sensors in the crust of the Earth. [7] Some IoT application are shown in Figure 2-2.

IoT Applications for :

- Home
- Cities
- Environment
- Energy Systems
- Retail
- Logistics
- Industry
- Agriculture
- Health & Lifestyle



Figure 2-2 IoT Application Domain

Smart Agriculture

In 2050 the world population is around 9.6 billion. For feeding this much of population the enhancement of Internet of things is very important. Against the challenges of extreme weather conditions such as climate change. More food is required to feed that much of population. For this purpose, the precision farming or smart agriculture is most important.

Smart farming based IoT technologies will help farmers. Farmers grow and promote the productivity generated by fertilizer, farm are made for that purpose.

The main question is what is smart farming? Smart farming is a capital-intensive and hi-tech system of growing food cleanly and sustainable for the masses. It is the application of modern ICT into agriculture.

In IoT-based smart farming, a system is built for monitoring the crop field with the help of sensors light, humidity, temperature, soil moisture, etc. and automating the irrigation system. The farmers can monitor the field conditions from anywhere. An IoT based system agriculture used for monitoring field of crops with the help of sensor light, humidity, temperature, soil moisture etc. Smart farming automatically monitors irrigation field. Farmers can monitor the field from anywhere. When smart agriculture is extremely efficient compared to the traditional viewpoint. The application of an IoT-based cannot only target traditional way but also a modern way of farming. Smart farming can provide many benefits including irrigation of water, Disease detection and pesticides for crops. The major applications of IoT Smart farming briefly discuss below.



Figure 2-3 Smart Agriculture

2.1 Application of IoT in Agriculture

2.1.1 Disease Based Application

Detection of Diseases in Grapes

Grapes cultivation has the economically and socially very important source of food. Grapes quality downed and the production of grapes is also decrease due to disease and less knowledge of information farmer has. In this system disease is early identified and according to that prediction we enhance the production of grapes. WSN are deployed in vineyard these wireless sensors take the reading of temperature, humidity and leaf wetness. These wireless sensors take data input of vineyard temperature, humidity etc. and transfer these data to server by using Zig-Bee module. Zig-Bee collect data from sensor and transmit these data to server. Wireless sensor is connected to Arduino board which convert analog system into digital. The data from sensor store in MySQL database. After data transmission system start data analysis for this Hidden Markov Model is used.



Figure 2-4 Vineyard Monitoring System

In this system Baum Welch algorithm is used. This model is based of three hidden state each state has some condition like leaf wetness or state changes from like state 2 to 1. By using Markov Model system classify the disease. The System is used for disease early

detection by using internet of things. This system help farmer to improve quality and production of Grapes. [8]

Disease and Pest Prediction IoT System in Orchard

Disease and Pest prediction system is used to reduce the diseases and insect which harm the orchard. The forecast IoT system consist on a weather station, prediction module and user app. Weather stations collects forward real-time weather information. Various type of sensors used to acquire data of humidity, temperature, dew, wind velocity and direction. These sensors connected with weather station near the orchard. Live real time display of the orchard. Weather Station transmitted data which stores in database. The pest prediction system examines weather information and forecast. Than calculate the probability of infection and occurrence date. Prediction module calculate the estimated date and stored in database. Than the estimated date is send to the user through app.

User use two type of applications. Pest forecasting and report is sent to the farmer through Android app. Farmer get the information of weather and estimated date. Web application is used for directors to get the information and weather data from all the station in real time. [9]



Fertilizers and Pesticide suggested system

System consist on three layers Data gathering, Database and Decision-Making approach. In first phase Temperature, Moisture and Humidity Sensors check the weather Condition and send data to Arduino. Than data is store in the Database. According to the condition of weather information will be provided to farmer from the Database. Last stage consists of a process of Decision making with help of Sensor appropriate quantity of fertilizers and pesticides will be suggested to the farmer after decision making.

Parameters result in the depletion of the growth of crops. The climate also plays an essential part in the cultivation of crops.

This system is be founded on IOT and Android area. The system is very useful for farmer the development of harvests. Sensor are used for detecting the atmosphere, checking the temperature and pH level of the soil. Temperature distinguishing ought to be conceivable either through direct contact with the warming source or remotely without organize contact with the source using transmitted essentialness. There is a wide grouping of temperature sensors accessible today including thermocouples assurance temperature locators' rtds thermistors infrared and Semiconductor Sensors. The LM35 can be related adequately comparatively as other composed circuit temperature sensors. It can be followed or set up to a surface and its temperature will be inside around the extent of 0.01°C of the surface temperature. Advances usually used to in a roundabout way measure volumetric water. [10]

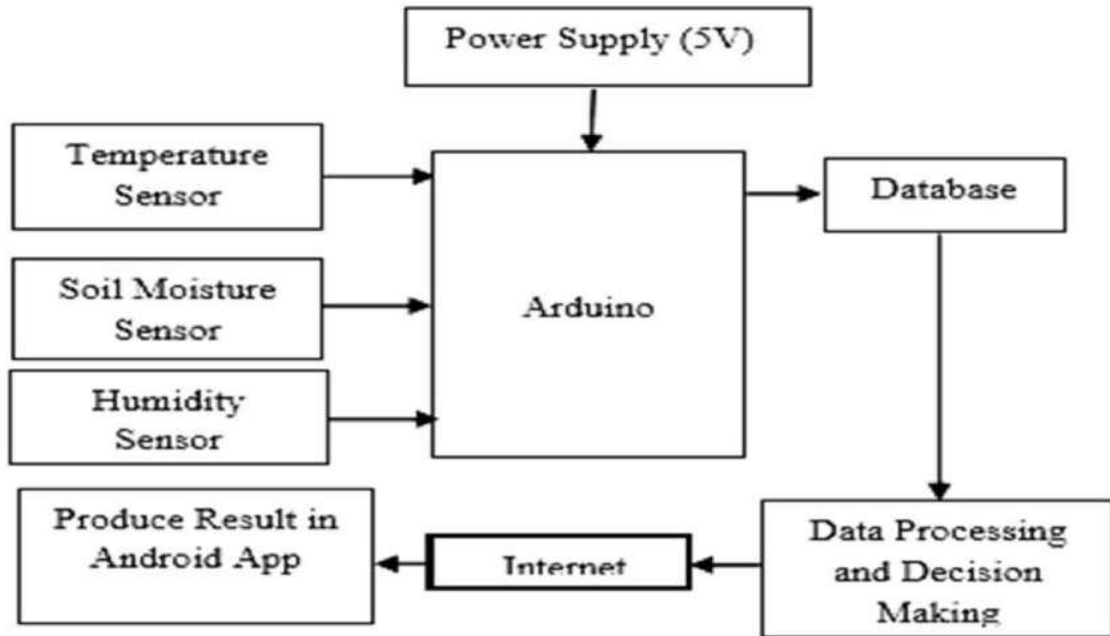

Figure 2-6 Diagram of Intelligent Fertilizer and Pesticides

Internet of Things Application to Monitoring Plant Disease and Insect Pests

In the monitoring system of agricultural disease and insect pests, the main aim is to achieve the disease and insect pests monitoring information and collection of the IOT. The system consists of sensor nodes, communication system, Internet, information service terminal and monitoring software and hardware system, and Sensor nodes are laid on targeted farmland areas and collected environmental signals are treated as a source of information.

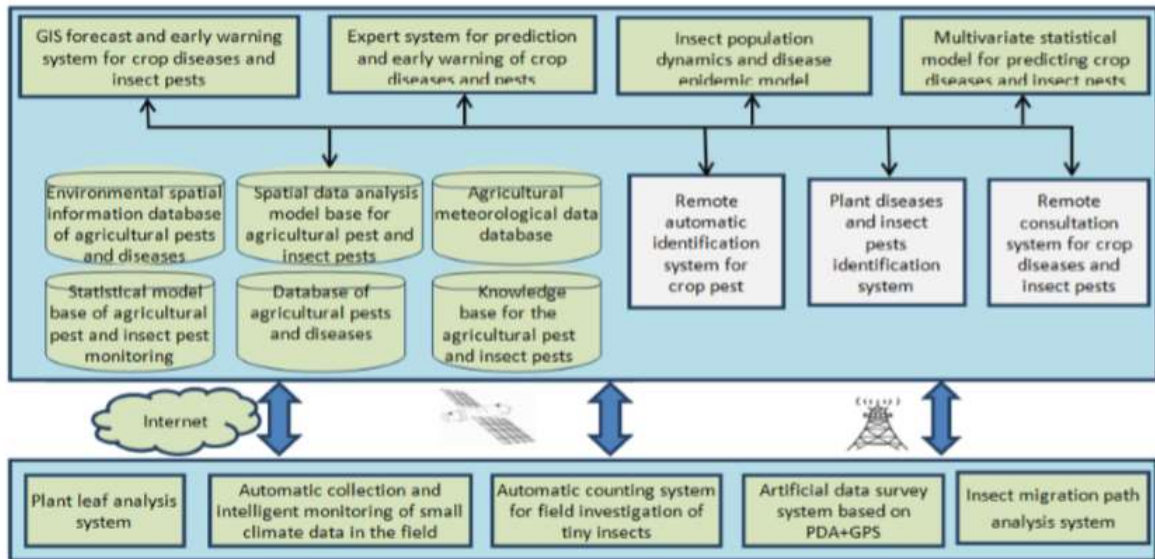

Figure 2-7 Agricultural disease and insect pest disasters information monitoring system

Disease and insect pest monitor system has experts, ordinary visitors and administrator. From any web or android device, they login to remote server and select real time data remote parameters and historical data by the monitoring sensor layer. Experts can analyze data and form an accurate database. The information platform of disease and insect pests monitor based on IOT is an integrated system that join all kinds of data which has agricultural knowledge, warehousing, purchase, retail and delivery information that interchange in different phases. The main function is data acquisition, reliable transmission, seamless connection and in-time search of information. [11]

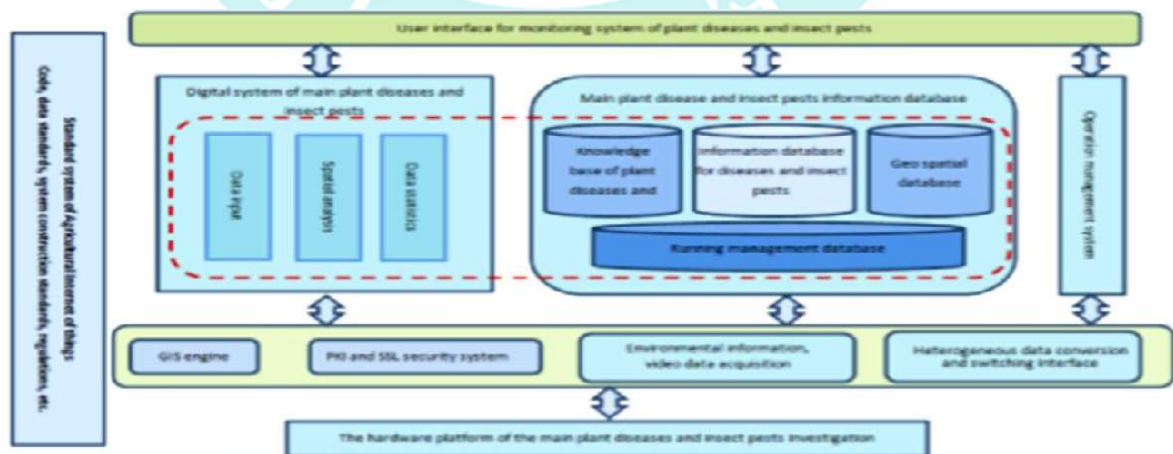

Figure 2-8 Structure of Monitoring Plant Disease and Insects Pests

2.1.2 Monitoring

Iot Based Smart Agricultural Monitoring System

Due to potential health risks after the use of insecticide, the cost of new wasting has increased rapidly in recent years. Government regulations have become more stringent, reducing the growth rate and consequently the price of new products increases. The biggest advantage of pesticides is that they are easily available and are very easy to use in contrast to alternative methods and other similar methods that can be taken long for planning and often but it does not matter. The system has wireless sensor network (WSN) to acquire data of water level, temperature and humidity. The data collected through sensors provided the detail information about the different environment factors.

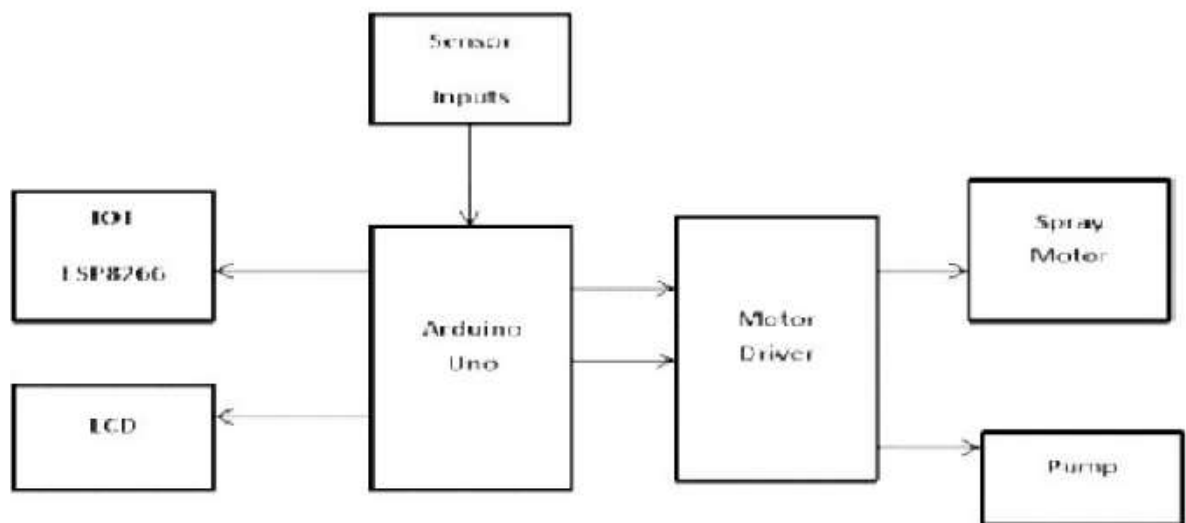

Figure 2-9 Block Diagram of Monitoring System

Thus, the system is useful to check the parameters for agriculture like temperature, moisture, humidity, leaf growth, spray the water and pesticides through the motor pump via IOT module. The system reduces the manual work, man power. This set up was carried out using Arduino UNO, Temperature and Humidity sensor, soil moisture sensor, ultrasonic sensor and IoT module. The Thing Speak page can be developed to control the system through the mobile. Damage caused by predators is reduced and also be used to increase the productivity. The system is integrated with ultrasonic

sensor to monitor the health of the plants to observe their plants anytime, anywhere on web. [12]

Automated Agricultural Field Analysis and Monitoring System Using IOT

Smart world is the result of the smart technology. Agriculture is the most important field, but the same traditional techniques like manual field monitoring, water feeding, pest detection, soil testing, etc. We are using for monitoring the field and frequently applying pesticides with or without having the knowledge of quantity to be used to control pests that affect the crops. So, it is very important to enhance the agricultural production by making use of technology to overcome the damages being done. Our aim is to provide smart monitoring system using the current technologies like IoT, cloud computing and image processing. “AAFAMS” (Automated Agricultural Field Analysis and Monitoring System Using IOT) is the system which is used not only for monitoring the field but also to suggest the farmers about the moisture content in soil, detecting pest and the type of crop suited for the soil. In AAFAMS, a line follower robot is developed by using a hardware kit called Raspberry pi, which monitors the soil moisture level at every 100m distance using a soil moisture sensor and the information obtained from the sensor will be sent to cloud for storage. A camera will be connected to the AAFAMS which will detect the pests. After complete survey of field AAFAMS retrieves all stored data from cloud and SQLite database to provide a detailed report of Moisture content and Pests information and suggests farmer with the required pesticide. AAFAMS runs either on batteries or solar panel by utilizing the solar energy available and thereby helping farmers to monitor their fields effectively.

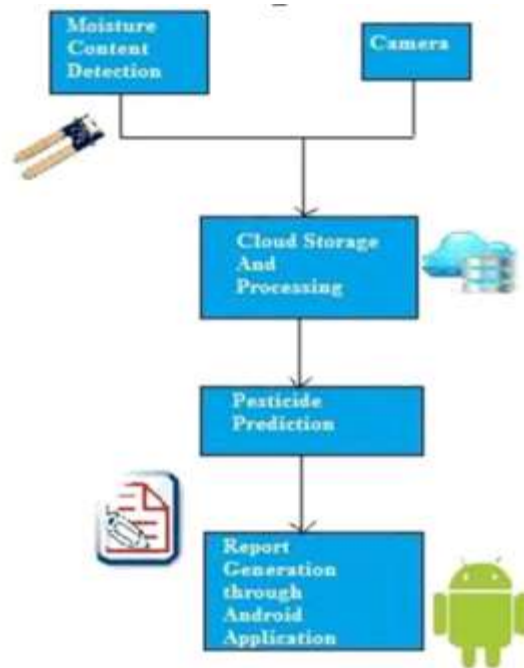

Figure 2-10 Block Diagram of AAFAMS

The objective of this is to simplify the task of farmers. [13]

IOT Based Crop-Field Monitoring and Irrigation Automation

In this way water and fertilizer are thrown into the roots of the plants regularly as the flavors of water. Designed for water application varies according to the type of crop. It uses 30-50% less water than the traditional method. The other way is potable irrigation in which the coast is more suitable for raining areas. The pitchers used here are fixed on the ground till the neck. The holes are made in pitches that throw the water around the soil and moisture for soil. This method is successful in areas where irrigation cannot be used. In other ways, the spraying method is like a natural rain. Water is distributed through a pipe system and then spreads in the air using sprinkling air to break into small water droplets. The pump supply can be designed in such a manner that water should be uniform at the soil level.

Soil moisture sensor, humidity sensors and temperature sensors are used for sensing data. Sensors nonstop monitor field and send data to web server using device NRF24LO1 transmitter to transmitted data on cloud. The data store with the help of sensor store in

database. Web Application is analyzing the data that receive from sensor and check with threshold values of humidity, moisture and temperature. Decision making start at server end and then start the process of irrigation according to value. If soil moisture value is less than threshold value water pump is on and if the soil moisture value is greater than the value of threshold the water pump is switch off. This method also be used for green houses.

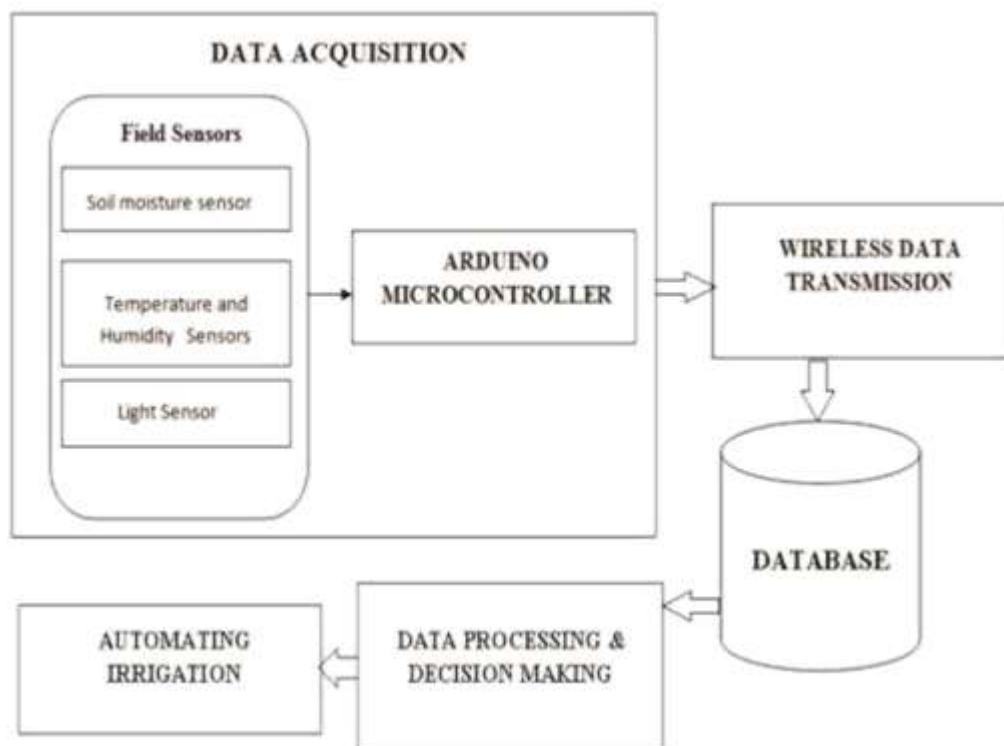

Figure 2-11 System Design

This system is very cost effective and it reduces the water consumption and it needs less maintenance power consumption. The system can be used in green houses. The System is very useful in areas where water scarcity is a major problem. The productivity of crop is increase and wastage is decrease through this process. [14]

Smart Monitoring of Potato Crop

Profitability of potatoes crop achieved if increase yield per hectare and production standards. Modern technology such as precision agriculture should ensure high profits

regarding potato crops. The biggest problem with precision agriculture has actually got data that could be very narrow and more difficult, but this problem could be less and less difficult because computing power and communication between different network systems Powerful, more user-friendly and less expensive. Precision farming is an application of Cyber Physical Systems.

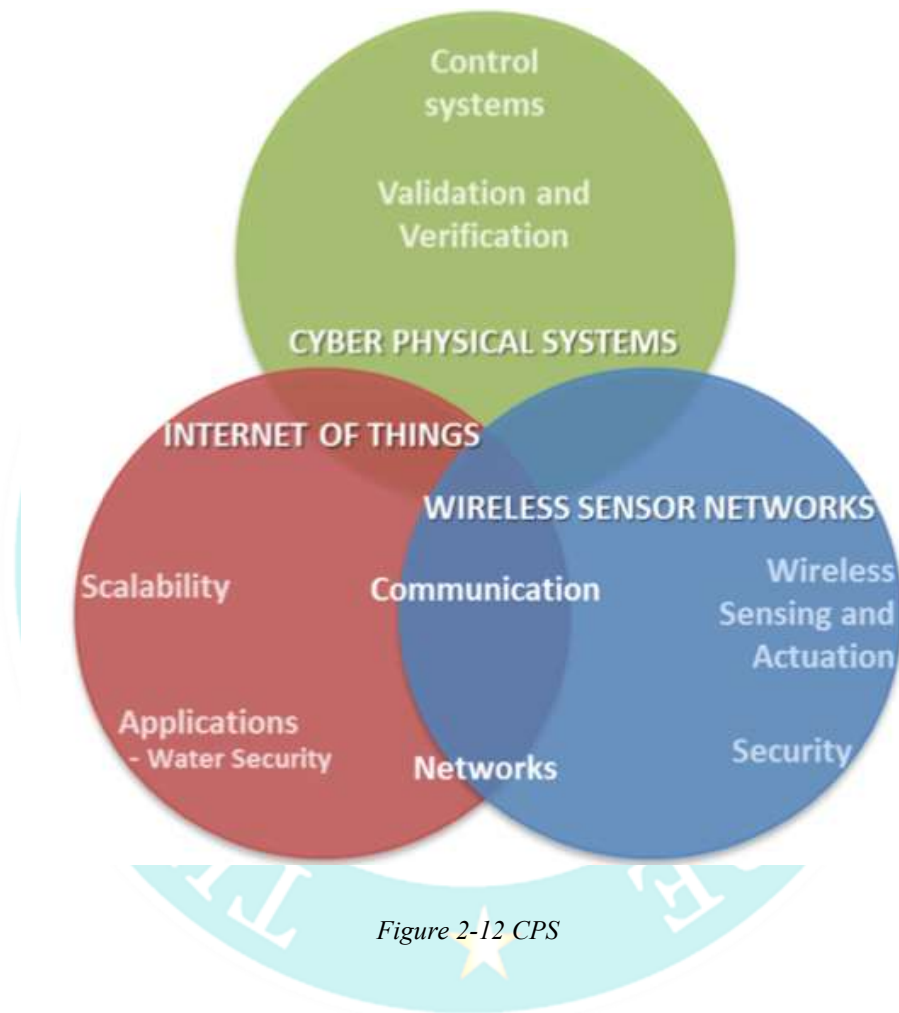

Figure 2-12 CPS

Precision agricultural management system is used for monitoring vegetation condition of potato crop by using CPS and design technologies. The proposed system allows farmers to follow the evolution of certain parameters of interest and make a fair decision to increase agricultural productivity. [15]

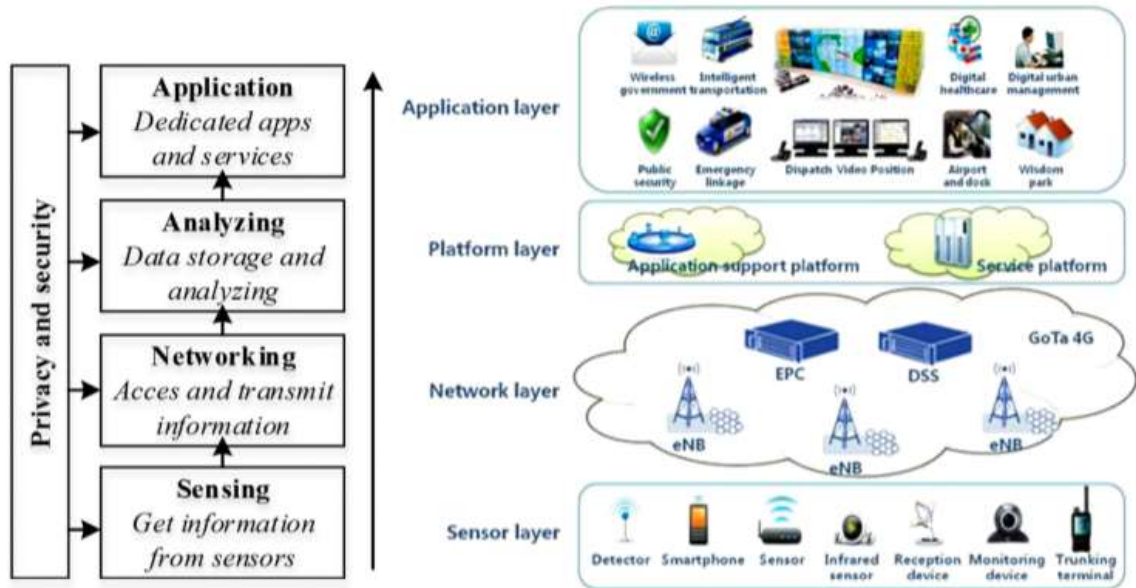

Figure 2-13 Four-layer architecture of IoT, WSN, M2M and CPS

Plant Growth using IoT and Image Processing.

The main idea of the system is joining the concept of Image Processing and IoT to the best result. Factors that considered are temperature and humidity for the betterment of health in Plant. The image capture by the camera and analyses the software name Matlab. The image capturing process and environmental factors is completed with the Internet of things network. Storage data store all the data for analysis. [16]

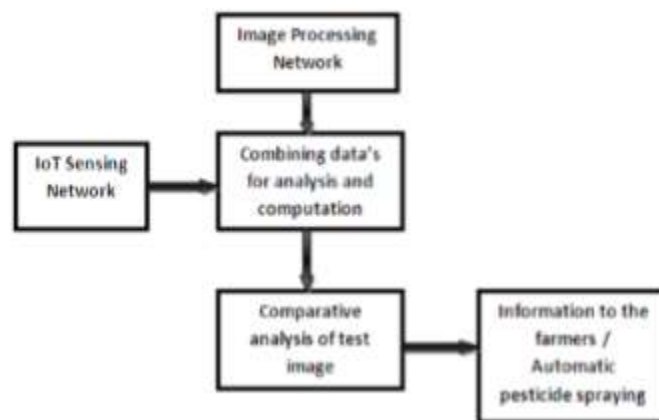

Figure 2-14 Image Processing

- Installation of sensor to send data
- Temperature and humidity value get with the help of analog pin.
- Print temperature C and Humidity in on the LCD
- Continue the read data step at a delay of 2000ms
- Uninstall the sensor and terminate

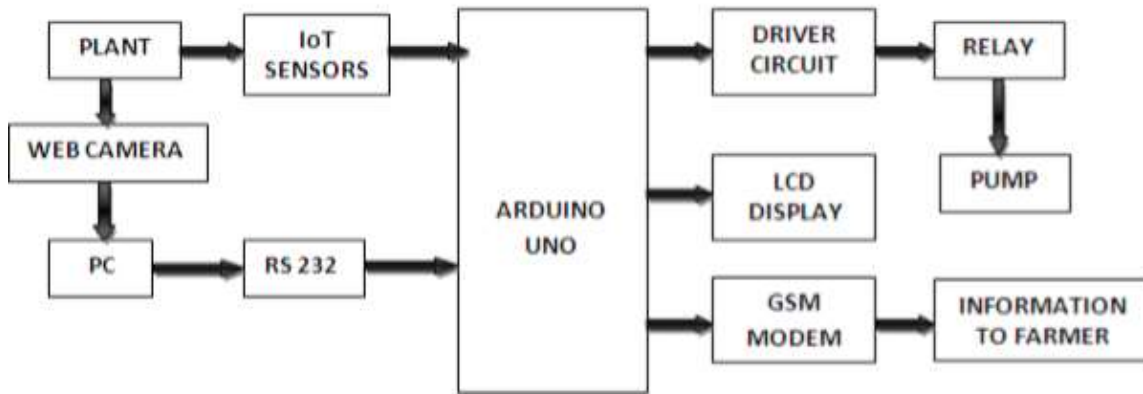

Figure 2-15 Image Processing with help of IoT

2.1.3 Soil Monitoring

The purpose of soil Monitoring is to provide embedded based system for soil monitoring and irrigation to reduce the manual monitoring of the field and get the information via mobile application.

An IoT Based System for Remote Monitoring of Soil Characteristics

Soil parameters through remote monitoring is an emerging trend which has capability to change agricultural and increase the productivity. Soil property is measure by pH value, moisture, and temperature its help us for fertilization process. Electrode is used to measure pH value. Soil moisture and humidity is taking place with the help of wireless sensor network. Soil temperature is measure by using the DS18B20 sensor working wire protocol. The system is connected by Bluetooth to send data on the Phone. Whole system name is STM32 Nucleon platform.

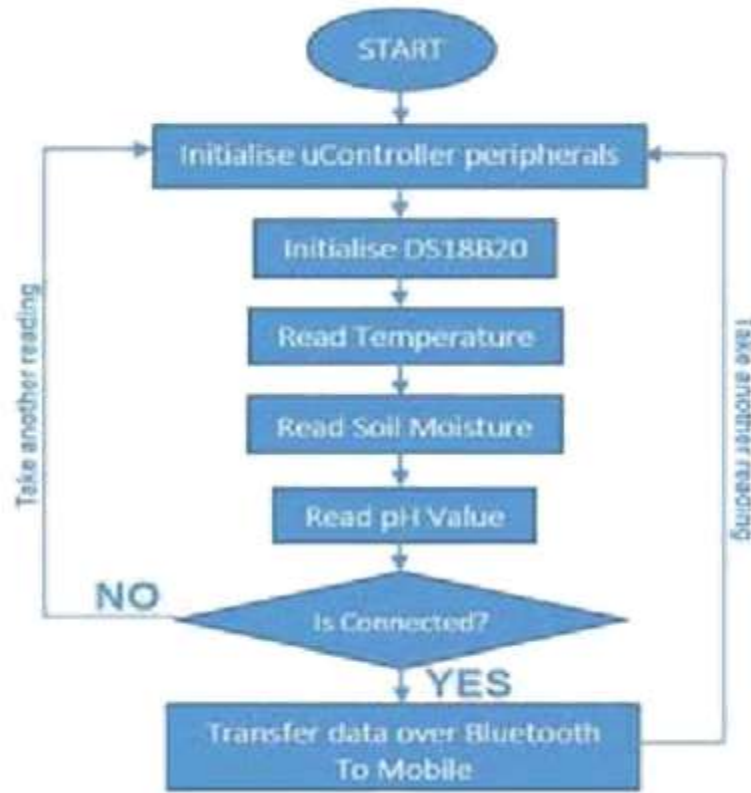

Figure 2-16 Firmware Flowchart

The system has been managed on STM32 board, Bluetooth is use for communication with farmer Mobile. Website developed for uploading sensor data to the cloud. [17]

Monitoring Citrus Soil Moisture and Nutrients Using an IoT Based System

Internet of things and single point multi-layer detection way is used to measure soil moistures, nutrient monitoring and temperature makes a citrus orchard fertilization irrigation knowledge-based method and make correct decision according to the condition of soil in real time to guide the actual production of citrus. Wireless sensor, data fusion and Internet technology make remote automatic monitoring system for emerging growth of citrus. And through model analysis and data processing, effective decision-making systems can take effectively manage the system. Practice has proved that a point multi-layer detection technology can increase the extent of detecting a lighter growth environment, and it is helpful to make another valid expert academic business. At the

same time, the system can guide the fruit farmers in improving the fruits of scientific pharmaceutical management and fruit production

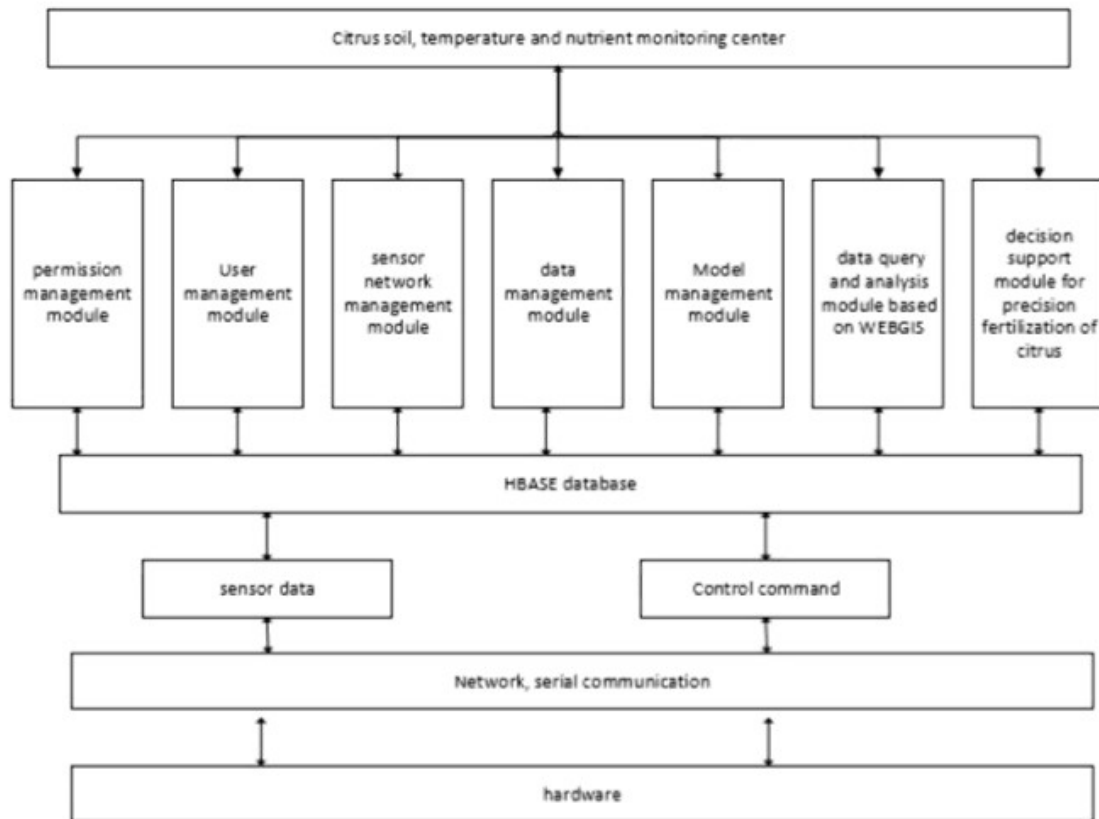

Figure 2-17 Software Architecture of Citrus Soil and Humidity Monitoring System

This idea connects between different services and improves the system's reliability. The only point to obtain temperature, moisture and nutrients is the modern approach of the multi-layer detection method. It will not only increase the detection threshold but also increase the accuracy of the model. According to the characteristics of the geographical environment and many years of management experience, the basis of special knowledge was established for the three Gorgeous Reserve area, which provided a model for the support of farm fertilizers and irrigation decision. [18]

Cloud based soil monitoring and smart irrigation system using IoT and precision farming

The planned stage safeguards fast access to organize Internet of things nodes, enables variable parameters on the sensor and to ensure that the overall sensor nodes are included, ensure equipment and modifications and rapidly setting up the prototype. On the hardware part, sensors like DHT11/22, pH rod, soil conductivity, soil moisture, and nutrients like NPK are identified and aggregated. Solenoid valve is used to control the water level which is irrigated via drip irrigation. By controlling the waste of water in such a way the crops are sent only to the appropriate amount of water.

Expanding solutions for data aggregation and analytics, efficient cluster head selection and integrating with open source programming platforms, (MQTT) and (CoAP), giving detailed experimental evaluation of performance metrics. [19]

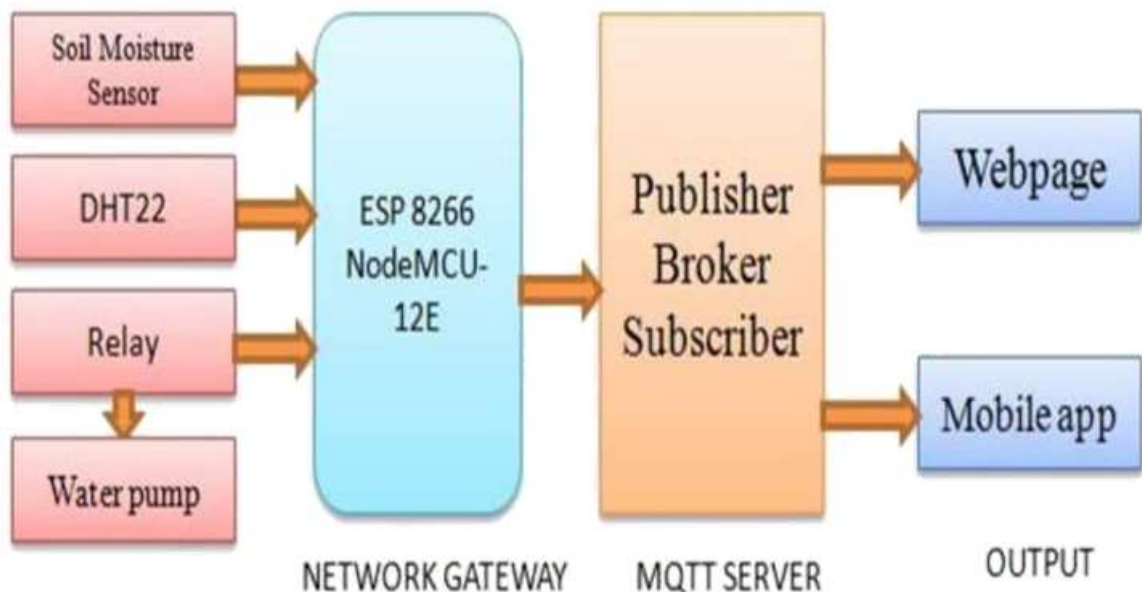

Figure 2-18 System Architecture

2.1.4 Irrigation Monitoring

Mobile Integrated Smart Irrigation Management and Monitoring System Using IOT

The System contain different types of sensor such as moisture sensor for measuring soil's water, temperature is detected by temperature sensor. DC Motor is design for irrigation purpose. Soil moisture electrode is buried in soil. It is used to read the value of that sensor and also read the value of temperature sensor.

If the value of Soil moisture is less, an alert message is generated and the Motor start the process of irrigation. When the soil moisture reached on final value Motor off and the supply of water is stop. Raspberry send all the information to cloud or server using Wifi module. "Blue term" connected with raspberry pi through Bluetooth to control the motor using text message. [20]

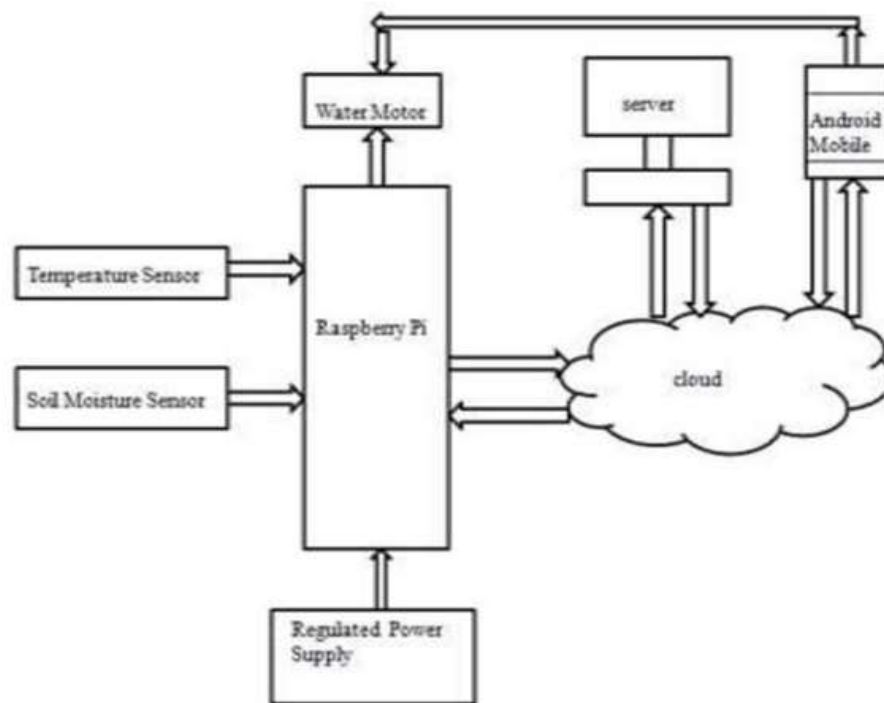

Figure 2-19 Mobile Automated Irrigation

Automated Irrigation System-IoT Based Approach

The Soil Moisture Sensor (SMS) is used to measure soil. Arduino is an electronics platform hardware. The Soil Moisture Sensor is connected with irrigation controller that measures soil moisture. The soil moisture sensor reads the value of moisture. Moisture data is upload on cloud through Arduino than the process of Data Analysis is start the value of moisture is compare with threshold value. If the value is smaller than the Water flowing start and if the threshold value is greater the water flow stops. [21]

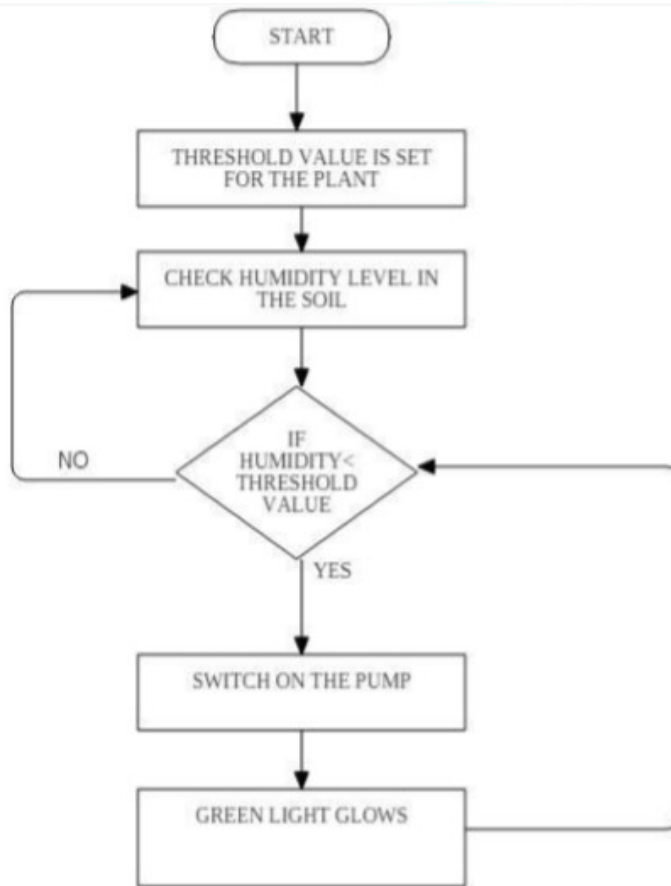

Figure 2-20 Automated Irrigation

Automated Irrigation System based on IoT and Wi-Fi

There are some ways to save water and harvest irrigation. Plant Evapotranspiration is an alternative parameter to solve estimation of irrigation water. Water used by plants during the period of time has been praised by Evapotranspiration. When water changes in the

vapor at the surface of the soil or soil, it has an effect. Water fall from leaves of plants is given as transpiration. ET estimate is the important factor: Local weather condition is first and the second is the cropping system for which evaluation are needed type of crop, crop development, planting date. By measuring four weather variables solar radiation, temperature, wind, humidity we can precisely predict ET losses in a given area. There are a lot of ways to calculate the information in the field. Data is collected through Zig-Bee network. The automatic irrigation system plays main role in adding of the evaporation, temperature and soil moisture content values might be sensed from the sensor and forward to the far area. The Wi-Fi module is used to do this. ESP8266 is interfaced to microcontroller. Using this, the values are updated in web periodically. The system receives the sensed values of temperature and soil moisture. [21]

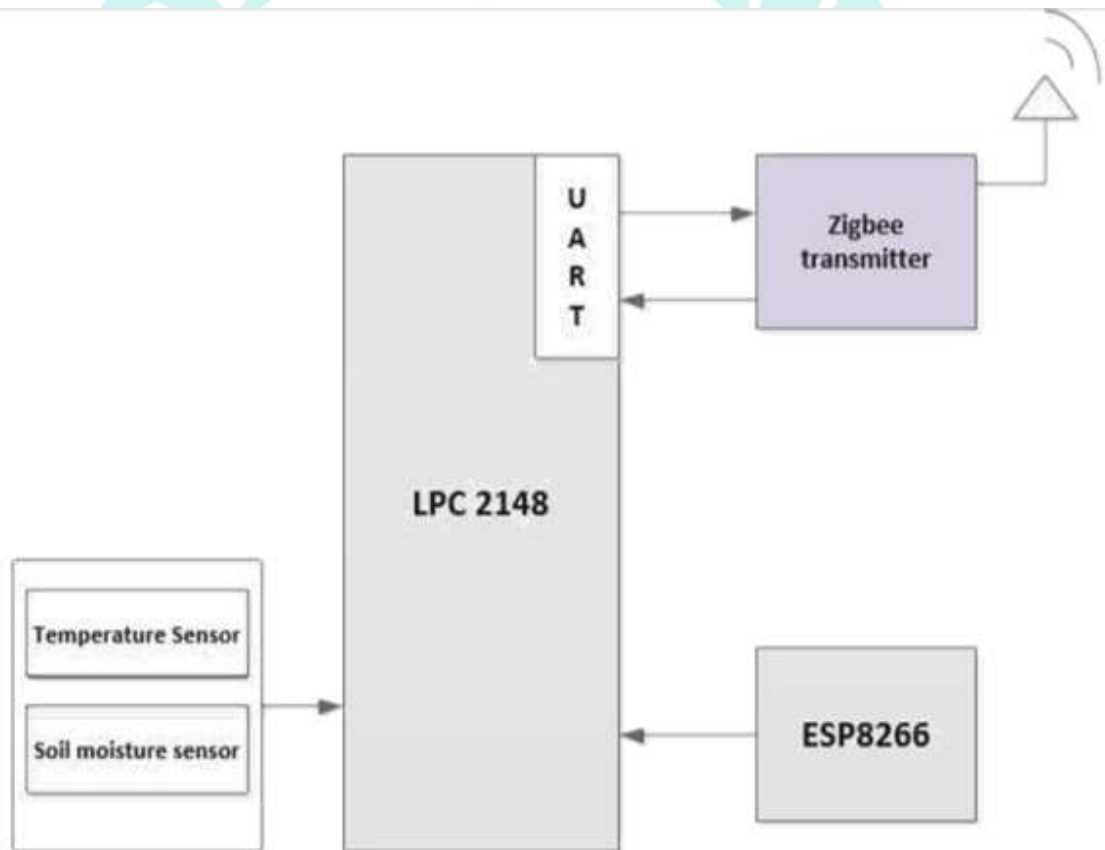

Figure 2-21 Diagram

Irrigation system plans can be determined as per the specific crop requirements and require minimum protection. The standard structure of Irrigation Systems which allows

it to automatically rate for large nurseries or open gardens. Despite being worried for the increase of water, nature should be re-powerful and moderate again for ensuring the natural environments, water conservation for the irrigation system. While at least accuracy while using ground water, and efficiency in irrigation system for water system, while increasing crop production.

IoT Based Smart Irrigation System and Nutrient Detection with Disease Analysis

The use of technology in agriculture is increasing, but a large part of agriculture, especially irrigation equipment. It seems that the production of the plant depends on the various factors. The maximum availability of water available in this regard is very important. The negotiation with farmers of Kerala Rice Station, and agricultural motivation shows that the current automatic irrigation facilities are expensive and some extent are wrong. It was the driving factor behind us to select automatic irrigation as a topic for our project. Providing a platform to monitor the irrigation system, irrigation and irrigation conditions, using earth moisture, will have an impact on the production of plants for temperature and moisture.

We built a weather irrigation system which contain Raspberry Pi as its main portion. Important factors related to water loss are environment temperature, moisture, wind patterns, and soil radiation patterns. Of these, we choose to consider prototype considering temperature and moisture, because it was relatively convenient and practical. For above purpose DH11 sensor is used and the digital readings sent to raspberry which got from sensor. [22]

2.2 Ontology & Semantic Framework

Ontologies is used for last decade to perform set of tasks. One of task of Ontology is achieve interoperability between heterogeneous information system. Ontology is used create communication between different agent like human or computer system by sharing information, data and knowledge. Ontology has different components like concept, properties, formula and instance

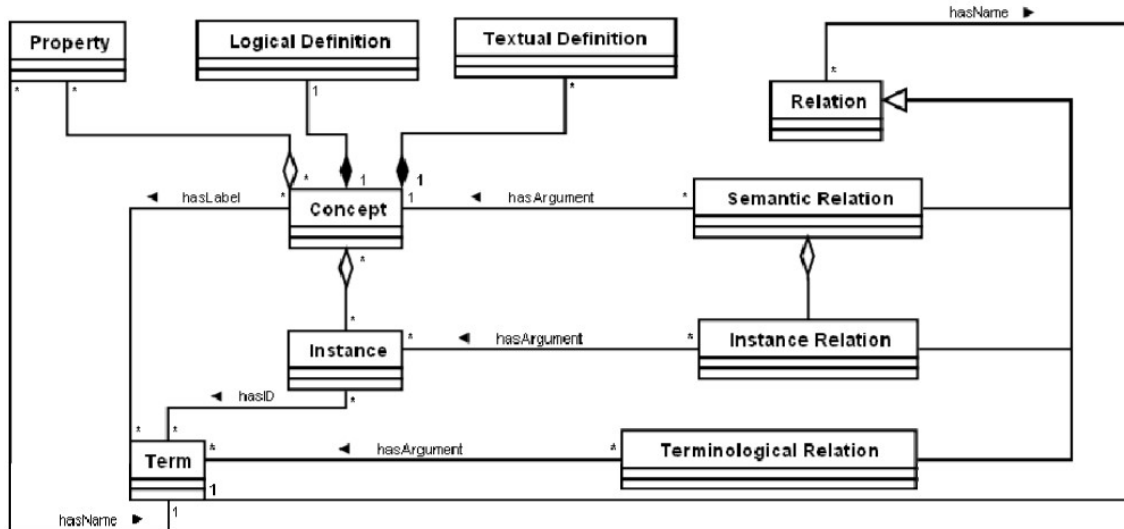

Figure 2-22 Scheme of relationship

Ontologies arrange the items or concepts of data in such a way that it creates meaning among them using relations and restrictions among the data terms and concepts so that vocabularies and taxonomies become more meaningful. The use of ontologies is to provide machine-processable semantics so that it can be shared among several other software and tools. [23]

Complex real-world concepts can be formally defined using ontologies. Ontologies can be logically reasoned and they can also be shared within a domain. The word shared refers to the concept that they capture consensual knowledge. So, it is accepted by the community or a group and is not restricted to an individual. Therefore, using ontologies, we can formally represent the concepts of a particular domain and also allow automated reasoning among those concepts. Because ontologies are shared concepts and provide a standardized solution, therefore, research is also focused on building technology for reuse of these ontologies, worldwide

Ontologies are used for defining terms in the domain and relationships among them. Defining concepts in the domain are termed as classes. These concepts are arranged in a hierarchy in the form of sub-classes. Object properties and data properties are assigned to these classes.

Smart agriculture Systems are hard to define formally because most of the systems lack standardization of architecture. By doing literature review of different Iot based agriculture systems we come to know that there are shared concepts in different smart agriculture systems

working in isolation. These shared concepts can be represented using ontologies, with the help of which we will not only be able to define smart agriculture system formally but also, we will find the commonalities and differences among these systems. By finding the shared concepts between these systems and defining them in ontologies, we can merge them in a cohesive system. This will lead us to the standardization of smart agriculture systems.



Chapter 3 **Methodology**



3.1 Introduction

Many systems are studied as the literature review of IoT based agriculture applications. These systems are working on requirement specific tasks. These Systems provide specific services based on the requirements which are fulfilled by performing different activities within these services.

This section of the thesis describes the plan of studies and solution exploration for integration of various smart agriculture architectures. The ontological modeling is being used for smart agriculture systems in depth definition. This ontological model is going to represent smart agriculture knowledge with its all semantic relations and constraints provided by them. This ontology modeling is done for different smart agriculture application which leads to find the commonalities and differences between the IoT based agriculture system. Exploring the commonalities and differences help to merge the modeled ontologies of different systems in one ontology of cohesive smart agriculture system.

In our scenario we have different smart agriculture applications working independently based on different services and activities. These services and their corresponding activities need to be managed jointly to form an IoT based cohesive agriculture solution and for this purpose we are making use of ontology engineering.

3.2 System Analysis

We have studied a number of systems in the domain of smart agriculture. These systems are working independently on their own architecture and standards. A number of smart agriculture systems are being studied and out of which 21 systems are selected for the analysis. The details of these 21 systems in the form of table are provided in appendix-I for consideration. These systems are classified on the basis of targeted requirements specified in the literature. These systems are classified in two categories namely disease-based system and service-based systems.

Service based systems provide different types of services i.e. Monitoring services, Irrigation services, harvesting services, Disease-based Service and Robotics Service etc. Monitoring systems provide different services like automated agriculture monitoring, rice crop monitoring, potato crop monitoring etc. Irrigation System provide irrigation management service in this service time and schedule of watering is decided. There is another type of irrigation service in which live monitoring of irrigation performed. These kinds of services help farmer to save their time and for better production of food by providing bi-directional communication over the cloud.

Service based systems can be further classified into two type of systems i.e. disease-based systems and robotics System. Disease based systems are disease specific and work on specific requirement driven service. For example, Disease detection of Cotton Crop system is used to detect different types of diseases in cotton crop. Grapes disease detection system is used to detect all kind of infections which occur due to moisture. Robotic system is used to performed different kind of functions like seeding and ploughing. Automatic Ploughing system in which robot perform the activity of plough with the help of farmer commands. These Systems are being performed by different services which are comprised of different activities. These activities within different services perform specific functionality depending on the type of system we are utilizing.

The detailed study of these systems shows that these systems have many common activities within similar services like data acquisition, data analysis and processing, data transmission. These common activities perform similar type of operations. The devices like sensors for such common activities may be different but the observation involving in them are quite same. For example, processes to detect and diagnose a disease may be different but the observation values will remain same. Frequency of observation will be similar but the analysis algorithm may vary for the processing purposes.

3.3Competency Questions

Competency questions in ontology engineering define the objective of the ontology to be built and they also are used to verify the ontology after it's developed. These questions are requirements that the ontology should be able to fulfill in answering them. And therefore, an

informal justification is presented using these questions by specifying the relationship between motivational scenarios and competency questions.

Our competency question for the development of ontology is as follows:

CQ1: How can smart agriculture be formally defined?

CQ2: How can the standardization of common smart agriculture service architecture and process model be achieved?

CQ3: How can smart agriculture services be merged over the commonalities and differences among variant architectures?

CQ4: What are the semantic relations and constraints within and across different Smart agriculture Architectures?

These competency questions define what we need from our solution of ontology. We will have to prove that software requirements can be defined (specified) in the form of ontologies and be validated as well. For the purpose, we have adopted ontology engineering methodology.

3.4 Ontology Engineering

3.4.1 Requirement Analysis

Ontologies are useful for representing and interrelating various knowledge. Since Requirement Engineering involves knowledge capturing and analysis, there is a clear synergy between the ontological modeling of a domain and the modeling that a Requirements Engineer will perform during the requirements process. Due to this overlap, numerous works dating back have addressed the use of ontologies in Requirement Engineering. The requirements considered need to be modeled to ontology use cases. These are different from software use cases used in domain modeling of the software requirements. It simply defines for what purpose it is to be developed, who will develop that and for what purpose it will be developed.

3.4.2 Use cases

We have developed 3 use cases for three different cohesive systems using 21 systems we are considering for ontology engineering. These use cases show different services of different systems working together to achieve one goal. These services are coined together to make an integrated smart agriculture system.

UC 1: Irrigation:

- Moisture Sensing (System 6 Service 1)
- Temperature Sensing (System 6 Service 1)
- Humidity Sensing (System 6 Service 1)
- Light Sensing (System 7 Service 1)
- Weather data (System 13 Service 2)
- Transfer Data to Cloud using Zig-Bee (System 10 Service 3)
- Combining data for analysis and computation (System 9 Service 2)
- K-mean clustering Accuration (System 13 Service 4)
- Generate Alarming Message (System 2 Service 4)
- Pump on Off (System 6 Service 3)

UC 2: Pest Control:

- Image Capturing (System 19 Service 1)
- Humidity Sensing (System 18 Service 1)
- Moisture Sensing (System 18 Service 1)
- Temperature Sensing (System 18 Service 1)
- Data Upload on cloud (System 8 Service 2)
- Image Remove Distortion (System 17 Service 2)
- Prediction of Forecast (System 11 Service 3)
- Prediction of Pest (System 11 Service 4)
- Cluster Analysis (System 18 Service 3)
- K- Mean Clustering (System 18 Service 3)

- Hierarchical Clustering (System 18 Service 3)
- Live Monitoring (System 11 Service 6)
- Average Moisture report (System 8 Service 3)
- Pest attacking report (System 8 Service 3)
- Pesticide for the crop report (System 8 Service 3)

UC 3: Ploughing and Seeding:

- Moisture Sensing (System 6 Service 1)
- Temperature Sensing (System 6 Service 1)
- Humidity Sensing (System 6 Service 1)
- Wireless Data Transmission (System 7 Service 2)
- Analyzing Data (System 7 Service 3)
- Command to robot (System 12 Service 1)
- Field Display (System 14 Service 2)
- Ploughing (System 12 Service 2)
- obstacle detection (System 21 Service 6)
- Break Obstacles (System 21 Service 6)
- Distributed Seed (System 14 Service 4)
- User Receive Output from Robot (System 20 Service 10)

3.5Glossary for Ontology

The first step in ontologies building is the concept. The final difference between the ontology and traditional representation is the analysis and level of relationship between the concepts.

System	Services	Activities	Field	Actors
Action Performed	Moisture Sensing	Data Acquisition	Monitoring Service	Director
IR Sensor	Disease based Services	Web Service	Weather Data	Image Collector
Data Processing	Web Application	Data Management	Harvesting Service	Machine

Prediction System for Disease and Pest	Obstacle Detection	Light Sensing	Analog to Digital Conversion	Wireless Data Transmission
Action Performed	Field Tiller	Software Application	Data Visualization	Diagnostic Activities
Weather Forecast System	UV Precipitation	Wireless Network System	Automated Robotic Service	Live Monitoring
Communication System	App and Services	Alarming Message	Weather Data	Humidity Display
Wind Velocity	Acidity Sensing	Video Streaming	Temperature Sensor Data	Image
Environmental Data	Data Analysis	Robot	Monitoring Services	Irrigation Service
Precision Agriculture	Disease and Pest Prediction System	Service based System	Spray	Meta Data
Watering	Farmer	Temperature Data Transfer	Cherry Tomato Crops	Mobile Irrigation System
Rice Crop	Air Temperature	Automated Irrigation System	Cotton Crop Image	Light Control
Seed Sowing	Moisture Sensing	Solenoid Value	Smart Agriculture Robot	Grape Leaf Image
Image Segmentation	Support Vector Machine	Grape Vineyards	Ploughing	Soil
Water Salt	Servo Motor	Robot for E-Farming	Water Sprinkle	Land Environment

3.6 Vocabulary Building

The Ontologies is initialized in the form of Classes.

Classes		Object Properties	Individuals
"Robot (Manipulator)"	LeafDiseaseRegionSegmentation	acquire By	Acidity
AciditySensing	LeafImageSegmentation	has	AirTemperature

ActionPerformed	LightControl	hasActivity	AnalogSignalConvertIntoDigitalSignal
Activities	LightSensing	hasObservation	AnalyzingData
Actors	LiveMonitoringOfIrrigation	performedBy	AndroidApp
ActualLeafRegionSegmentation	LocationOfInfectedArea	processedBy	AndroidApplicationForFarmer
AirTemperatureSensing	Machine	providedBy	AutomatedIrrigationService
Alarm	MeasureMoisture	transmittedBy	BreakingObstacle
AllowStartAndStopWaterFlow	MeterlogocalDataset		Camera
AnalogtoDigitalConversion	Moisture		Chlorophyll
AppAndServices	MonitoringPlantDiseaseAndInsectPest		ClusterAnalysis
Arduino	MonitoringService		CombiningDataForAnalysisAndComputation
ArduinoAnalogSystem	MonitoringSystem		CommandToRobot
AutonomousRobotForE-Farming	MotorDriver		CottonCropImage
Bulb	Motors		CropImage
CalculateMomentum	NitrogenSensing		DataAnalysisUnit
CalculatingEuclideanDistance	Observations		DataMiningSystem
Camera	ObstacleDetectionInField		DataTramissionUnit
CapturedImageOfRiceCrop	OpenAndCloseContainer		DataTransmissionToCloud
CherryTomatoCrop	OperationsOfPloughing		DataUploadOnCloud

ChlorophyllSensing	OutputAngle		DcMotor
ClassificationThroughSVM	owl:Nothing		Dew
ClimateSensing	PedoAndAgrodemData		DewSensing
CloudReceiveInputFromRobot	Person		DigitalSystem
CloudSendInputFromUserToRobot	PesticideSpray		DiseaseAndPestPredictionService
ColorImageCapture	PhosphorousSensing		DistributedSeed
CombineWithClimateData	Plants		EnvironmentSignal
CommandFromWebBrowser	PLCRobotHarvestFruit		FieldDisplay
CommunicationSystem	Ploughing		GenerateAlarmingMessage
CommunicationSystems	PloughingThroughRobot		GrapeLeafImage
ComputeAngleOfHarvesting	PotassiumSensing		HierarchicalClustering
ConvertDataAnalogToDigitalImage	PouringWaterOnField		Humidity
CropBasedSystems	PrecisionAgricultureUsingAgribot		HumiditySensing
CropMonitoringAndIrrigationAutomation	Prediction		ImageCapturing
DataAcquisition	PredictionSystemForDisease&Pest		ImageDistortionRemove
DataAnalysis	PredictionSystemForForecast		K-MeanClustering
DataMiningMethodForPredictionOfDisease	PumpOnOf		K-meanClusteringForAccuration
DataProcessing	PumpOnOff		Light

DataStoreInDatabase	RaspberryPi		LightSensing
DataTransmission	Report		LiveMonitoring
DataTransmissionToCloud	ReportSendToFarmer		Matlab
DataVisualization	Result		MobileIrrigationService
DecisionLayer	RiceCrop		Moisture
DecisionMaking	RiceCropMonitoringSystem		MoistureAnalysis
DedicateAppAndSServices	RoboticService		MoistureReport
DetectInsectMigrationPath	RobotMovement		MoistureSensing
DetectionOfInfectedArea	RobotWatering		MonitoringSystem
DHT11SensorCheckHumidityAir	SeedSowing		Nitrogen
DigitalSystem	SeedSowing1		ObstacleDetection
DilationProcessing	SeedStorageInContainer		PestAttackingReport
Director	SendMessageToFarmer		PesticideReport
DiseaseDetectionOfCottonCrop	SendResultOnWebApplication		Phosphorus
DiseasePredictionOnPlants	Sensors		Ploughing
DiseaseService	Service		Potassium
DisplayCoordinateInXAndY	ServiceBasedSystems		PredictionOfDisease
DistributedSeed	SmartAgriculturalMonitoring		PredictionOfForecast

EarlyDetectionGrapesDisease	SMARTAGRICULTUREROBOT		PredictionOfPest
EarlyWarning	SmartAgricultureSystem		PredictionSystemForDisease&Pest
EnvironmentSignal	SmartIrrigationManagementSystem		PredictionSystemForForecast
ErosionProcessing	SmartIrrigationMonitoringSystem		PumpOnOff
Farmer	SmartMonitoringPotatoCrop		ReportGenerateForDirectors
FarmerCommand	SoftwareApplication		ReportGenerateForFarmer
FeatureExtraction	SoilData		Robot
Field	SoilMoistureSensing		Seed
FieldTiller	SoilResourceData		ServoMotor
FinalPredictedSoilMoisture	SoilTemperatureSensing		Soil
GisForecast	SolenoidValue		SoilTemperature
GrapeLeaf	Spray		Spray
GrapeVineyard	Sprayer		Sys1_AutomatedIrrigationSystem
GSM	SprayerMachine		Sys2_MobileIrrigationSystem
Harvesting	StartAndStopIrrigation		Sys3_DiseaseAndPestPredictionSystem
HarvestingService	StateTransitionProbability		Temperature
Humidity	SupportVectorMachine		TemperatureSensing
HumidityDisplay	System		Time

HumiditySensing1	Tap		TomatoCropImage
IdentificationFruitMaturity	TargetDistanceMeasurement		UC1_IrrigationService
ImageAcquisition	Temperature		UC1_IrrigationSystem
ImageBinaryProcessing	TemperatureData		UC2_PestControlService
ImageCollector	TemperatureDataTransfer		UC2_PestControlSystem
ImageEnhancement	TemperatureSensing		UC3_PloughingAndSeedingService
ImageIdentification	TemperatureSensing2		UC3_PloughingAndSeedingSystem
ImageOfPlantsThroughWebcam	TransferDataToCloudUsingZig-Bee		UltrasonicSensor
ImagePre-Processing	TransmittedDataToWebserver		UserReceiveOutputFromRobotViaCloud
ImageSegmentation	User		Video
ImagesOfCrops	UserCommandThroughMobileApp		WaterFlow
ImageTransmissionToCloud	UVPrecipitation		WaterPump
InformationGathering	VegetationStateData		WaterSalt
InformationToFarmer	VideoStreamingOfRiceCrop		WaterTap
InsectPopulationDynamics	WaterData		Weather
InvestigationTinyInsects	WATERING		WeatherData
Irrigation	WaterPump		WeatherForecast
IrrigationService	WaterSprinkle		WeatherStation

IrSensor	WaterSprinkleOnOff		WebApplication
LandEnvironment	WeatherCenter		WebApplicationForDirectors
LCD	WeatherData		WindSpeedSensing
LCDDisplay	WeatherDataAcquisitionSystem		WindVelocity
WebCam	WeatherStation		WirelessDataTransmission
WebServiceForWeatherForecast	WebApplicationAnalysesData		WirelessSensorSystem
WebServiceSystem	WebBrowser		Zig-BeeNetwork

3.7 Taxonomy Building

Taxonomies have been proven successful in resolving several problems in computerized systems using in different sciences. It has also been used in software requirements analysis to understand several concepts and to resolve particular problems. Several other taxonomies have been proposed by others for requirements engineering in general. They also provide the basis for the implementation of ontology. Taxonomy is a network of classes, sub-classes, and individuals. After all the terms to be used in our taxonomy are chosen, the next step is to identify the proper placements of these terms in our taxonomy. We have adopted bottom up (Generalization) approach. A bottom-up development process starts with the definition of the most specific classes, the leaves of the hierarchy, with subsequent grouping of these classes into more general concepts.

In our system we have defined some super classes like Actors, Services, Activities, Machine, Field, Observation and Smart Agriculture Systems. Actors class has different physical stakeholders in it i.e. it has a sub class of Machine and Person. Person has Farmer, User and Director in it. Machine has sub classes like communication system, Motors, Robots, Sensors, Software Application, Water Tap etc. Same like that Observation has different data values

like Moisture, Humidity, Acidity, Temperature etc. Actor and Observation classes are certainly involved in mostly Smart agriculture Systems. We have 21 different smart agriculture services known to us on studying different IoT agriculture systems. To combine them under one class we have used Services class. This services class is arranged in major subclasses like Monitoring Services, Disease based Services, Robotic Services, Harvesting Service and Irrigation Systems etc. These subclasses in Services superclass contain all types of services used in different systems under study.

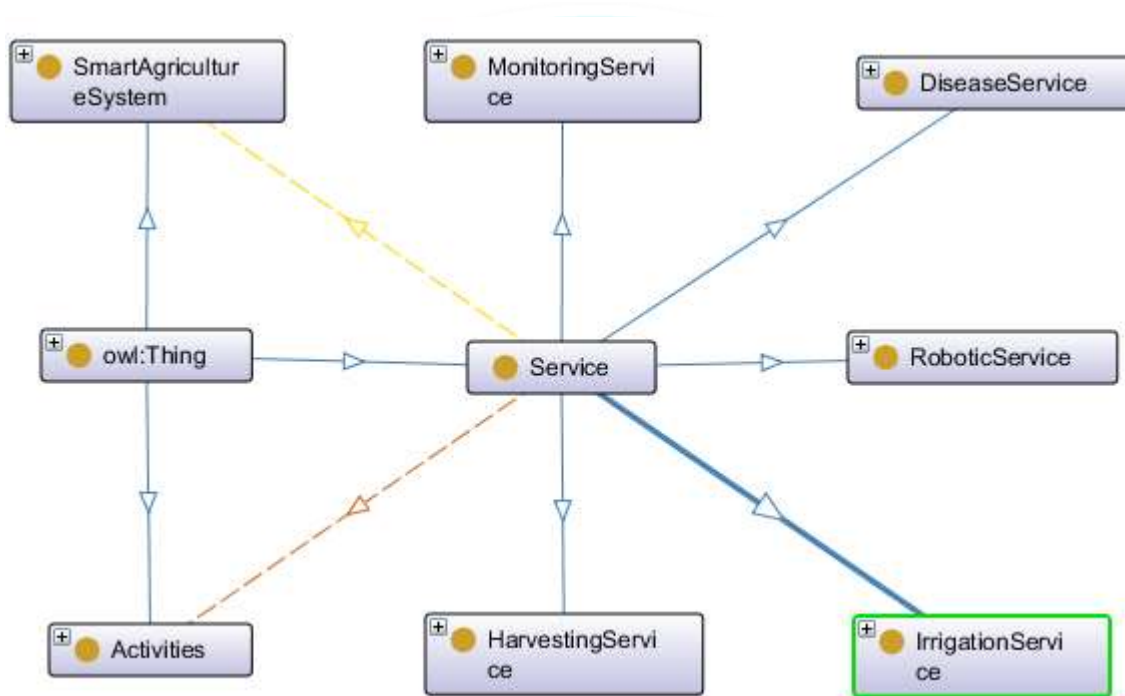

Figure 3-1 Taxonomy and Semantic Relation of Service Class

Different types of services are provided in the Services class. Fig 3.1

These services are further containing many sub services.

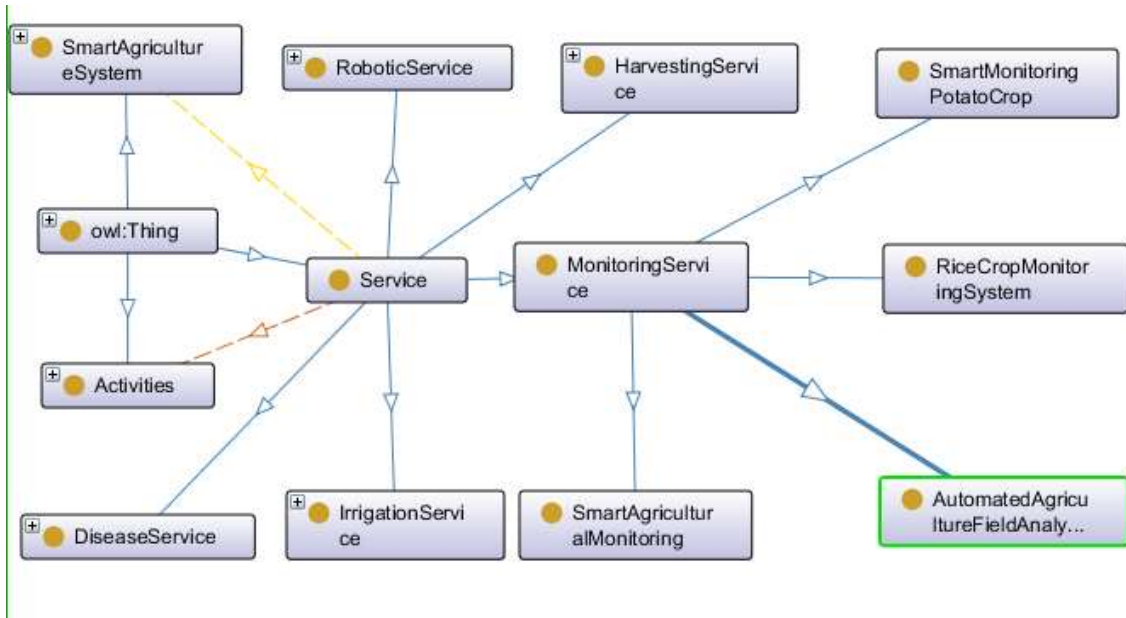

Figure 3-2 Taxonomy & Semantic Monitoring Service class

Monitoring service has sub class of Smart monitoring of Potato Crop, Rice Crop monitoring and Automated Field Analysis as shown in Figure 3-2

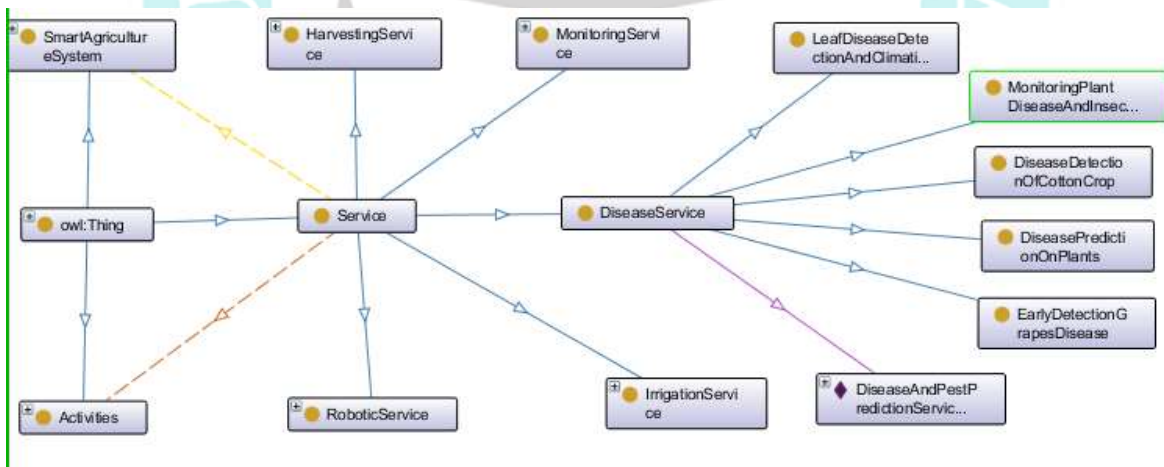

Figure 3-3 Taxonomy & Semantic Disease Service class

Disease services are further divided in sub classes shown in Figure 3.3

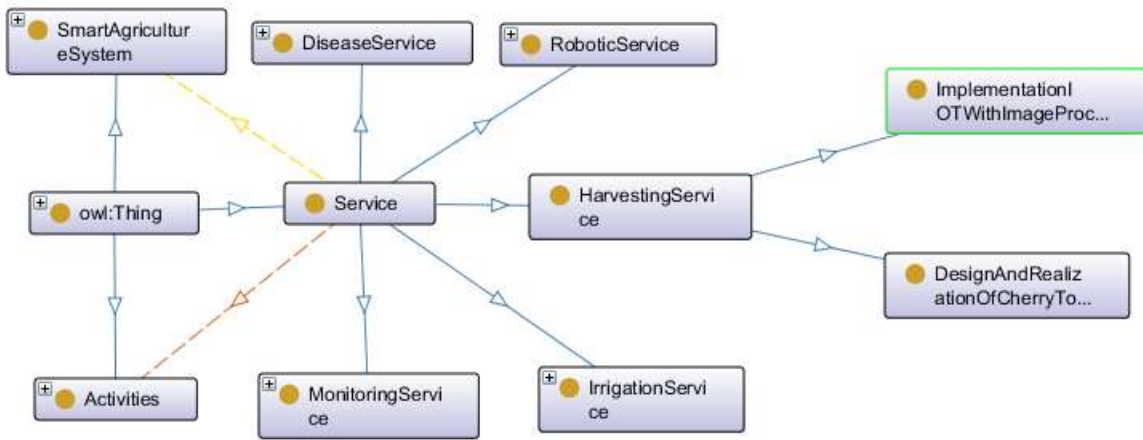

Figure 3-4 Taxonomy & Semantic Harvesting Service class

Harvesting services are further divided in sub classes shown in Figure 3.4

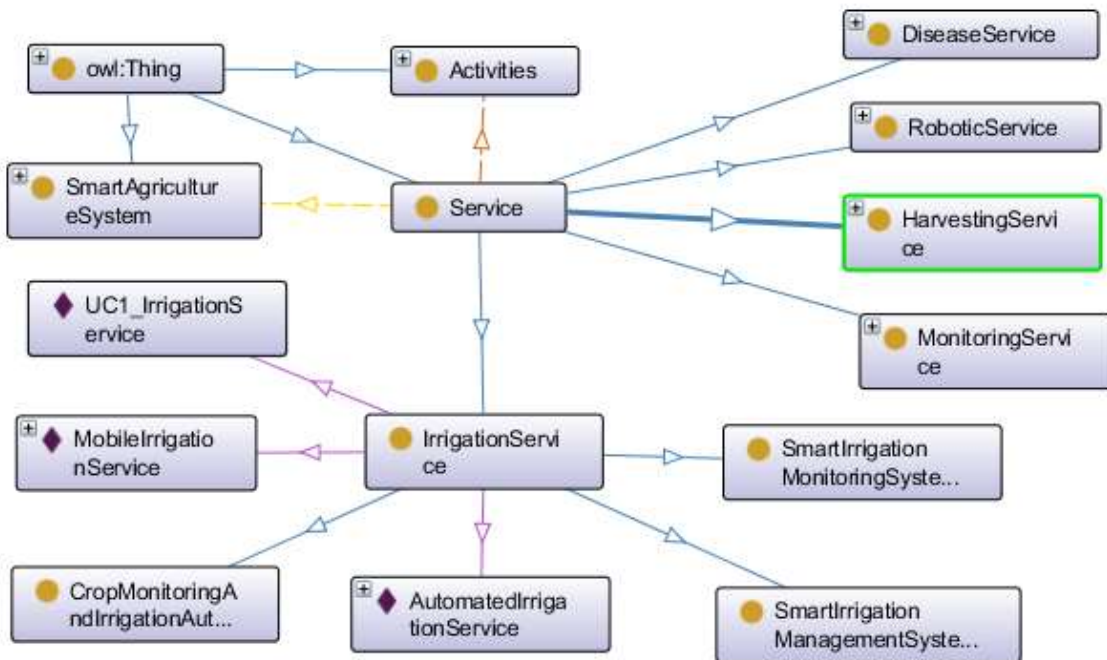

Figure 3-5 Taxonomy & Semantic Irrigation Service class

Irrigation services are further divided in sub classes shown in Figure 3.3

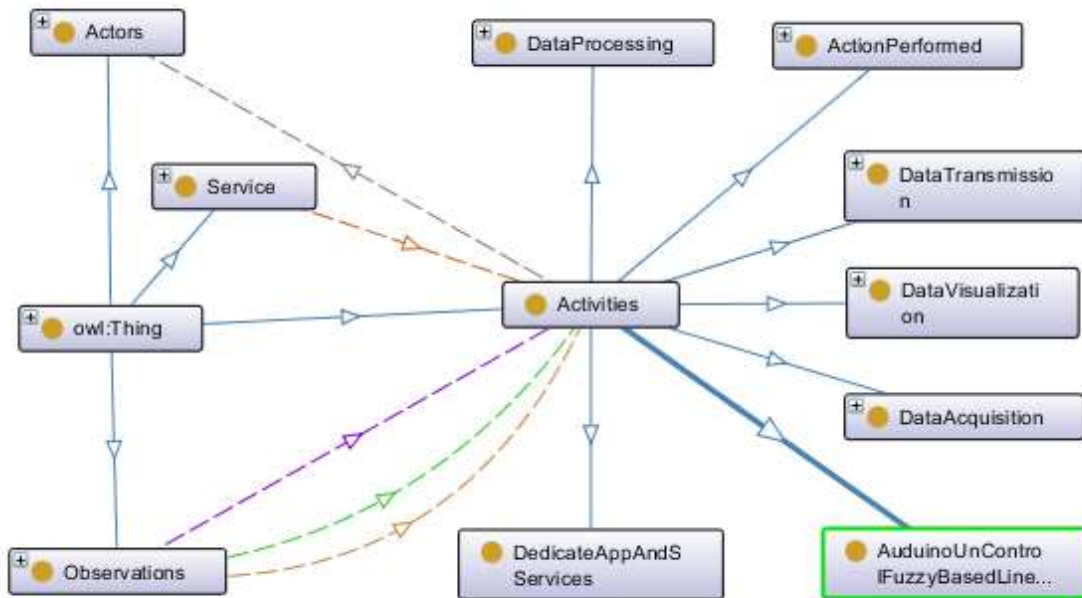

Figure 3-6 Taxonomy & Semantic relations of Activities

Different services have different activities we have an activities class which has many sub classes shown in Figure 3.6. Activities class has different classes like Data Acquisition, Action Performed, Data Transmission, Data Visualization, Data Processing, Dedicate App and Services. These activities are performed accordingly to related services. After taking data from Observation activities are performed on that data like data acquisition, Data processing, Data transmission etc.

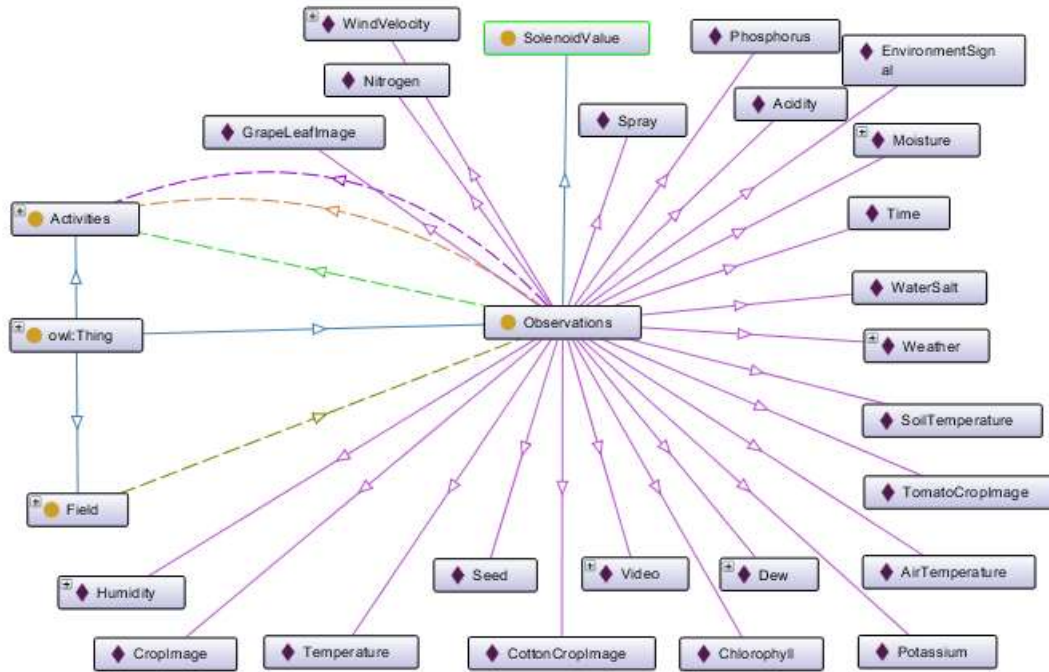

Figure 3-7 Taxonomy & Semantic Relation of Observation Class

Fig 3.7 shows Observation class is a super class that contains different subclasses like Moisture, Time, Temperature, Water Salt, Weather, Soil Temperature, Tomato Crop Image, Dew, Wind Velocity, Solenoid Value, Potassium etc. On these observation different activities are performed.

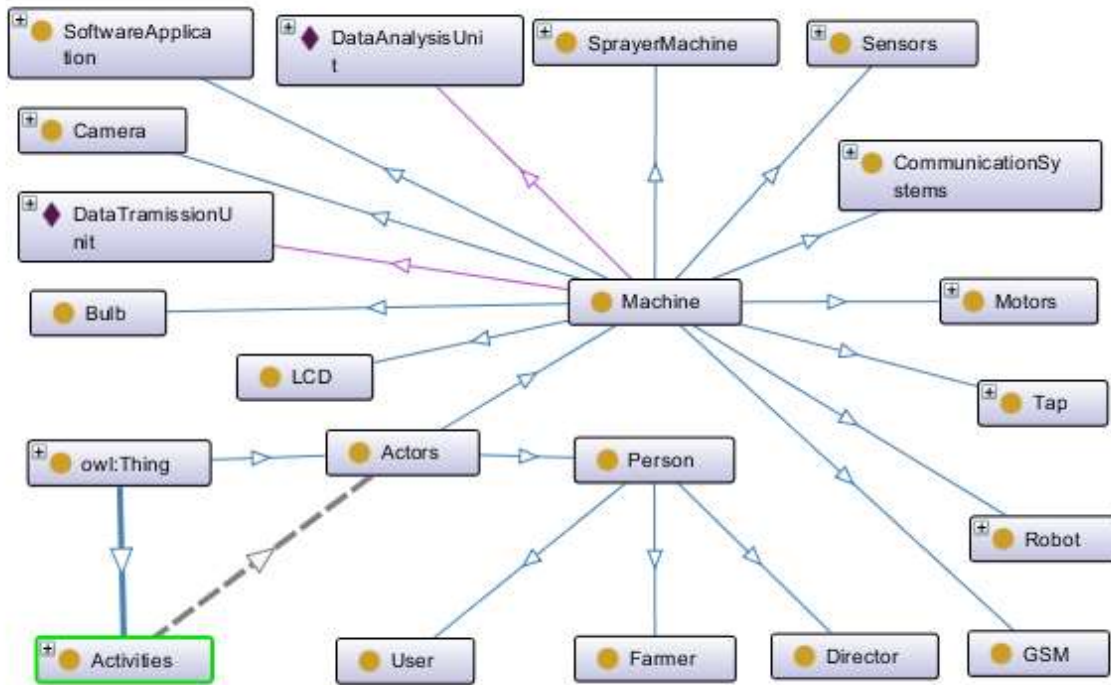

Figure 3-8 Taxonomy & Semantic Relation of Actor Class

Fig 3.8 shows the expansion of superclass Actors which has different subclasses i.e. Person class, Machine class. Person class has sub class of Farmer, User, Director. Machine class has subclass Software Application, Data Analysis Unit, Sprayer machine, Sensors, Camera, Communication Systems, Data transmission unit, Bulb, LCD, Motors, Tap, Robot.

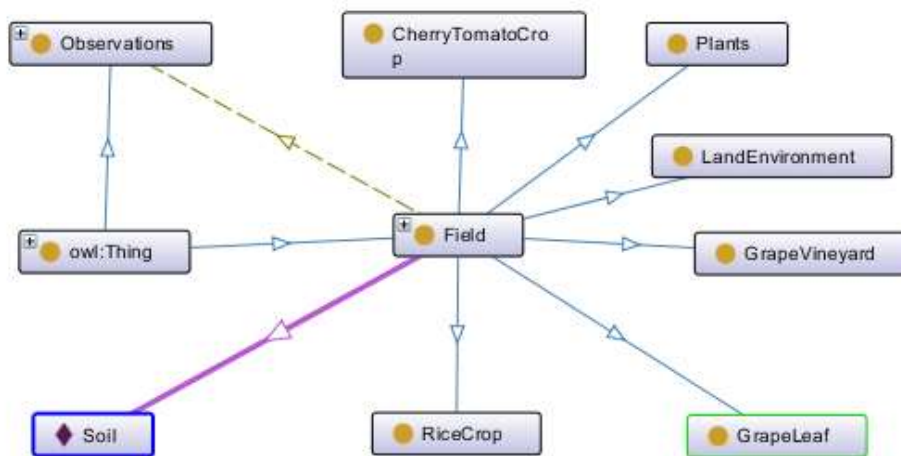

Figure 3-9 Taxonomy & Semantic Relation of Field Class

Different actions are performed on Field class like ploughing and seeding etc. Field class has different sub classes like Soil, Land environment, Grape Leaf, Grape Vineyard, Rice crop, Plants, Cherry Tomato Crops shown in figure 3-9

3.8 Semantic Relations

The conceptual structures that clearly define the ontology provide the key to machine-processable data on the Semantic Web. Ontologies assist as metadata schemas, serving a controlled vocabulary of concepts, each with unambiguously defined and machine-processable semantic relationship. By outlining shared and common concepts, ontologies help people and machines to communicate concisely supporting semantics exchange, not only just syntax. The semantic relations are represented through the predicates defined in two different concepts like services, systems, actor or disease.

- **Service is provided by Smart Agriculture Systems:**

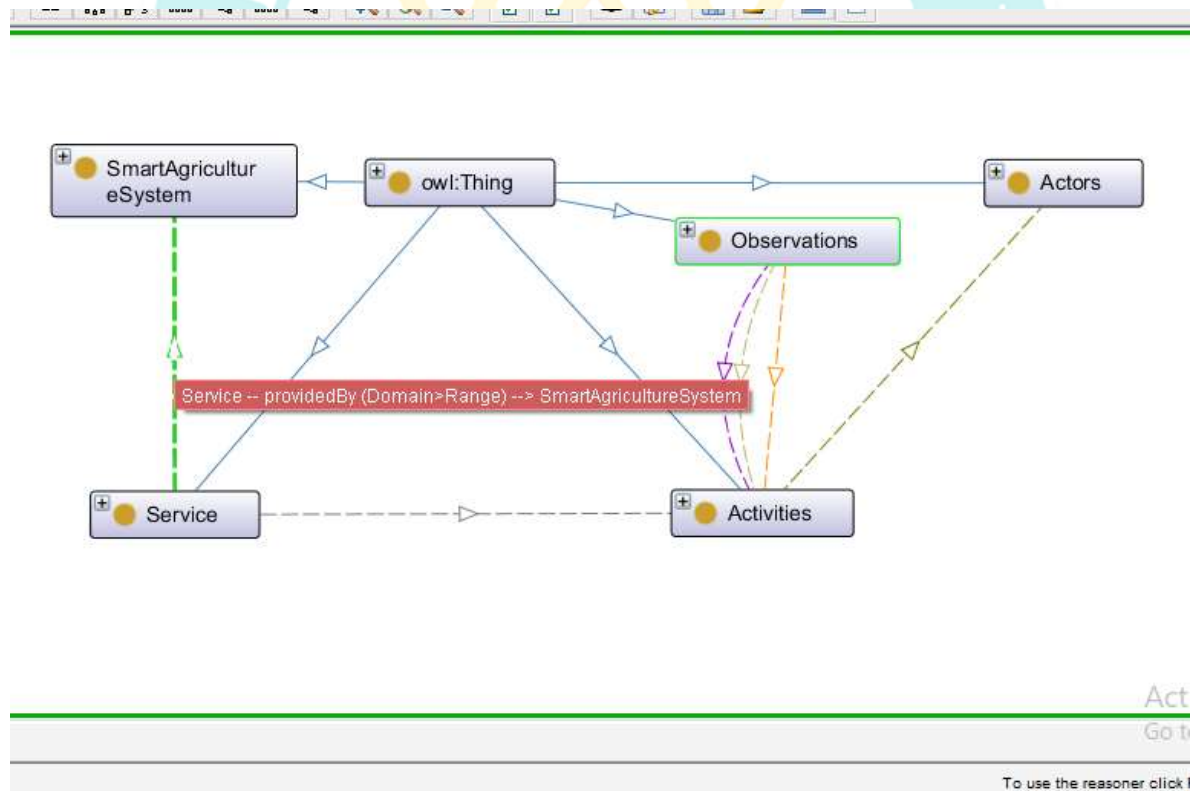

Figure 3-10 Semantic Relation of Service and System

- **Service has Activities:**

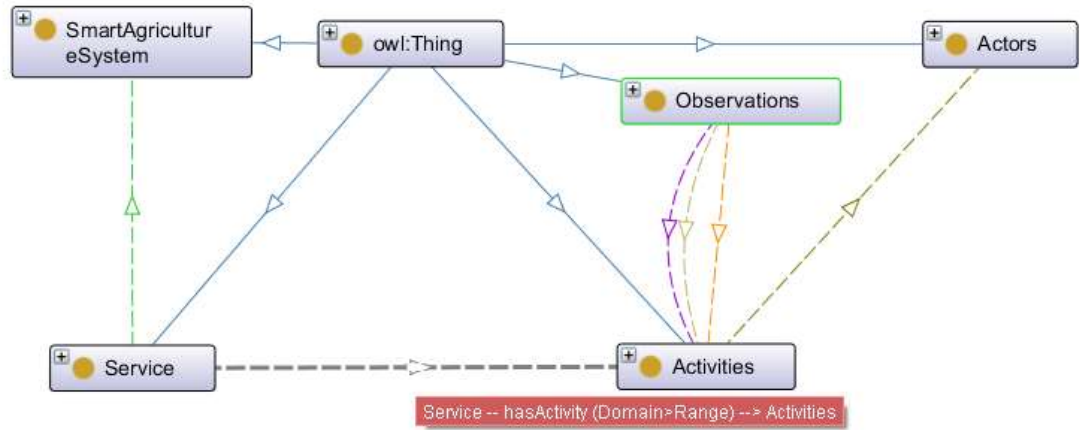

Figure 3-11 Semantic Relation of Service and Activities

- **Activities performed by Actors:**

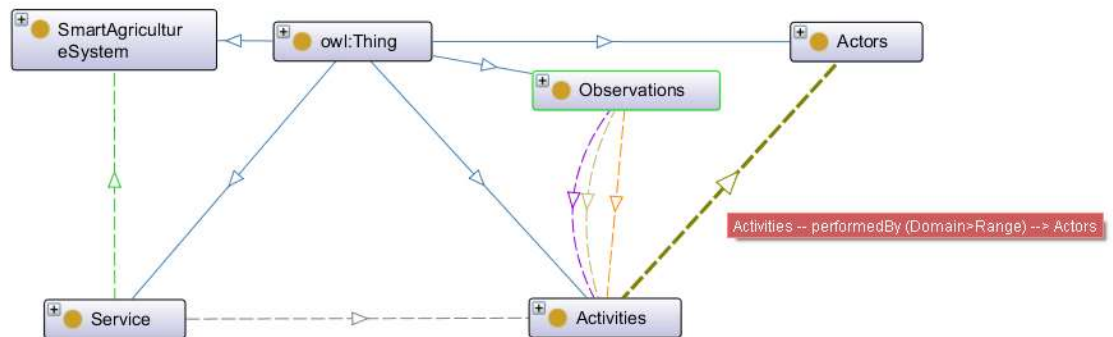

Figure 3-12 Semantic Relation of Activities and Actors

- **Observations acquired by activities:**

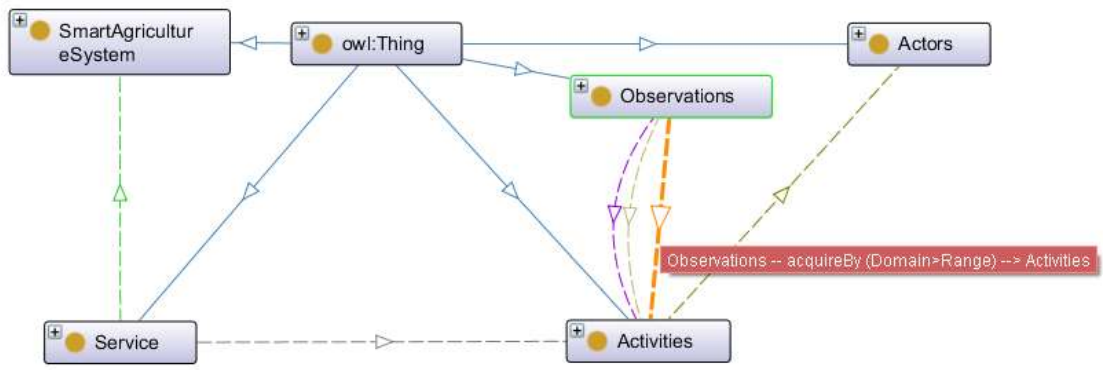

Figure 3-13 Semantic Relation of Observation and Activities

- **Observation transmitted by activities**

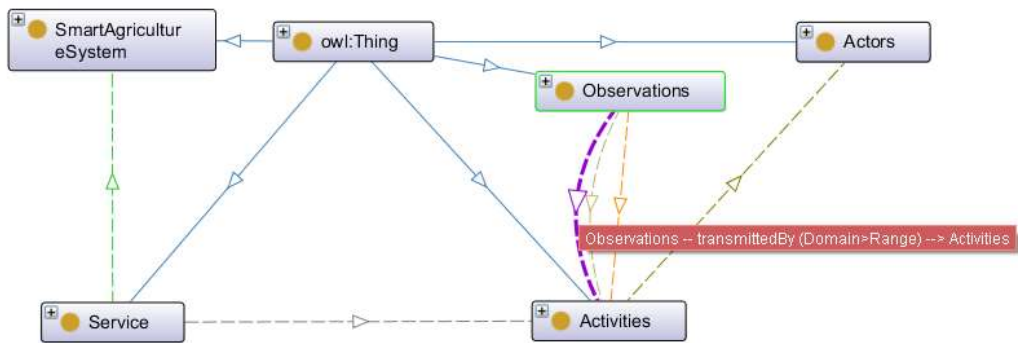

Figure 3-14 Semantic Relation of Observation and Activities

- **Observations processed by Activities**

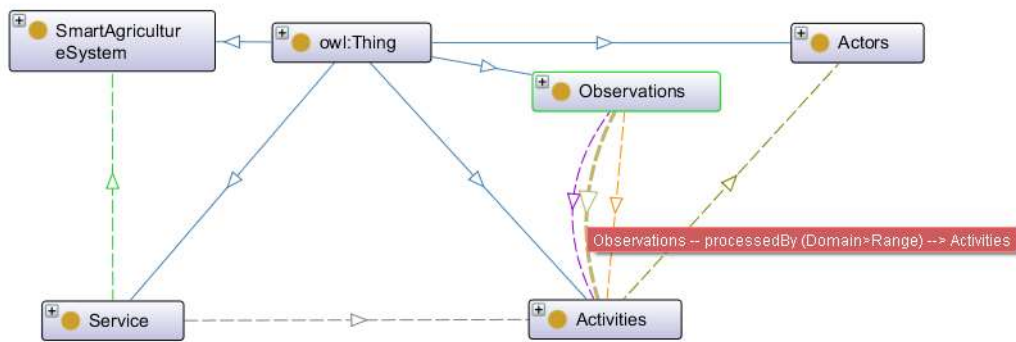

Figure 3-15 Semantic Relation of Observation and Activities

3.9 Constraints

In addition to the semantic relations and possible connections of knowledge, system constraints are also defined. These constraints represent the binding of some concept being disjoint with not allowed relations. These constraints include following system restrictions:

- Temperature cannot be sensed by Moisture Sensor
- Moisture cannot be sensed by Temperature Sensor
- Farmer does not have Disease
- Pest control spay is never finished.
- Fields are not watered manually.

Chapter 4 **Experimenta tion & Results**



4.1 Instantiation

In this section we will show how we can analyze an individual to view all of its related object properties in better understanding different dimensions of individuals in software development process. We will show all the object properties in our ontology used and discussed in this section. Object property assertions may be represented by different arc types in the whole document because of the selection of arc types by Protégé for selected number of individuals in a search. But the legend in figure will correspond to only the object properties described in this section therefore, most of the object properties shown elsewhere might not be consistent with this legend because for them, their legend is provided elsewhere with them or mentioned in their discussion.

After, we have completed the creation of ontology and represented it only then we can be interested in viewing all roles individual object properties. In this, we will first show all the object properties of Smart Cohesive agriculture System individuals. Then we will move on to showing all object properties of End User type individuals. Since, each derived individual in the domain ontology represents the specific requirement of the intended software. Since we are concerned with capturing the requirements specification in ontology, among other advantages of this approach is that we can examine all possible relations related to a single requirement or individual through that very individual.

Such approach of object properties and data properties and linking with the main classes provide insights into the inner, deeper and the smallest possible details of each software requirement that might not be specified entirely in paper-based SRS. In the similar manner of creating object properties, data properties are also created and maintained like for example, Moisture, Temperature reading and humidity of soil etc. Therefore, complete requirements ontology is made of specific software.

Now we will move on to the validation of our competency question in our next section and therefore the methodology we applied for software requirements specification using ontology. Validation is of two types. One is reasoner based which checks for inconsistencies.

And the SPARQL queries will show us if we are actually been able to define the software requirements.

4.2 SPARQL Based Validation

SPARQL is an SQL like query language. For our validation we use SPARQL for the answer of ours questions. Queries answer our question and prove the logic we built. The queries are written in the DL Query portion in Protégé.

The screenshot shows a SPARQL query editor with a purple header. The query text is as follows:

```

SPARQL query:
PREFIX rdf: <http://www.w3.org/1999/02/22-rdf-syntax-ns#>
PREFIX owl: <http://www.w3.org/2002/07/owl#>
PREFIX rdfs: <http://www.w3.org/2000/01/rdf-schema#>
PREFIX xsd: <http://www.w3.org/2001/XMLSchema#>
SELECT DISTINCT *

WHERE {

  <http://www.semanticweb.org/farrukh/ontologies/2019/2/untitled-ontology-11#UC1_IrrigationService> ?predicate ?object

}

```

Below the query, a table displays the results. The table has two columns: 'predicate' and 'object'.

predicate	object
rdf:type	IrrigationService
rdf:type	owl:NamedIndividual
hasActivity	WeatherData
hasActivity	LightSensing
hasActivity	K-meanClusteringForAccuration
providedBy	UC1_IrrigationSystem
hasActivity	MoistureSensing
hasActivity	HumiditySensing
hasActivity	DataTransmissionToCloud
hasActivity	TemperatureSensing
hasActivity	CombiningDataForAnalysisAndComputation
hasActivity	PumpOnOff

Figure 4-1 SPARQL Query of Use case 1

Our first use case is verified from the query shown in figure 4-1 which is UC1_IrrigationService. This service belongs to the Irrigation class and this service is provided by UC1_IrrigationSystem. The result of the query shows that this service has different

activities from different system. UC1_IrrigationService has many activities like UC1_IrrigationSystem has Activity of Moisture Sensing, Humidity Sensing and Temperature Sensing: These services is used to acquire moisture, temperature and humidity data of Soil. UC1_IrrigationService has two more Activity of Weather Data and Light Sensing: These activities are used to acquire data of climate and Light. UC1_IrrigationService has Activity DataTransmissionToCloud in this activity data gather from above activities upload on cloud. The Next Activity is CombiningDataForAnalysisAndComputation in this activity we analyses data. Next two activities are UC1_IrrigationService has Activity K-MeanClusteringForAccuration: this activity is used for decision making. UC1_Irrigation System has Activity of PumpOnOff for water flow

```
SPARQL query:
PREFIX rdf: <http://www.w3.org/1999/02/22-rdf-syntax-ns#>
PREFIX owl: <http://www.w3.org/2002/07/owl#>
PREFIX rdfs: <http://www.w3.org/2000/01/rdf-schema#>
PREFIX xsd: <http://www.w3.org/2001/XMLSchema#>
SELECT DISTINCT *
WHERE {
  <http://www.semanticweb.org/farrukh/ontologies/2019/2/untitled-ontology-11#UC2_PestControlService> ?predicate ?object
}
```

predicate	object
hasActivity	DataUploadOnCloud
rdf.type	owl:NamedIndividual
hasActivity	MoistureReport
hasActivity	HierarchicalClustering
hasActivity	LiveMonitoring
hasActivity	K-MeanClustering
hasActivity	HumiditySensing
providedBy	UC2_PestControlSystem
hasActivity	PredictionOfForecast
hasActivity	PredictionOfPest
hasActivity	ClusterAnalysis
hasActivity	ImageCapturing
hasActivity	PestAttackingReport
rdf.type	DiseaseService
hasActivity	TemperatureSensing
hasActivity	PesticideReport
hasActivity	ImageDistortionRemove
hasActivity	MoistureSensing

Figure 4-2 SPARQL Query of Use case 2

Figure 4-2 show the query in which we describe the 2nd Use case name is UC2_PestControlService provided by UC2_PestControlSystem. This service has a list of activities like UC_PestControlService has activity of Moisture sensing, Temperature Sensing, Humidity Sensing: these activities acquire data Moisture, Temperature and Humidity. UC_PestControlService has activity of Image Capturing for images of crops. UC_PestControlService has activity DataUploadOnCloud : acquire from above activities is transmitted to cloud. UC_PestControlService has activities for data mining: the name of data mining activities are K-meanClustering, HierarchicalClustering and Clustering analysis. UC2_PestControlSystem has activities of Prediction of Pest and Prediction of Forecast. UC_PestControlSystem has activities of generating reports like Pesticide Report, Pest Attacking Report and these reports send to User to Android App.

SPARQL query: 🏠 📄 🗑️

```

PREFIX rdf: <http://www.w3.org/1999/02/22-rdf-syntax-ns#>
PREFIX owl: <http://www.w3.org/2002/07/owl#>
PREFIX rdfs: <http://www.w3.org/2000/01/rdf-schema#>
PREFIX xsd: <http://www.w3.org/2001/XMLSchema#>
SELECT DISTINCT *

WHERE {

  <http://www.semanticweb.org/farrukh/ontologies/2019/2/untitled-ontology-11#UC3_PloughingAndSeedingService> ?predicate
  ?object
}

```

predicate	object
hasActivity	CommandToRobot
rdf:type	owl:NamedIndividual
rdf:type	RoboticService
hasActivity	HumiditySensing
hasActivity	UserReceiveOutputFromRobotViaCloud
hasActivity	BreakingObstacle
hasActivity	FieldDisplay
providedBy	UC3_PloughingAndSeedingSystem
hasActivity	DistributedSeed
hasActivity	TemperatureSensing
hasActivity	WirelessDataTransmission
hasActivity	MoistureSensing

Figure 4-3 SPARQL Query of Use case 3

Fig 4.3 the query show UC_PloughingAndSeedingService provide by UC3_PloughingAndSeedingSystem. UC_PloughingAndSeedingService has activity for data acqisiting like Moisture sensing, humidity sending and temperature sensing. UC_PloughingAndSeedingService has activities wireless data transmission, command to robot, Robotic service, Breaking Obstacle, Distributed Seed, Field display and User receive output from robot via cloud.

SPARQL query:

```

PREFIX rdf: <http://www.w3.org/1999/02/22-rdf-syntax-ns#>
PREFIX owl: <http://www.w3.org/2002/07/owl#>
PREFIX rdfs: <http://www.w3.org/2000/01/rdf-schema#>
PREFIX xsd: <http://www.w3.org/2001/XMLSchema#>
SELECT DISTINCT *

WHERE {

  <http://www.semanticweb.org/farrukh/ontologies/2019/2/untitled-ontology-11#AutomatedIrrigationService> ?predicate ?object
}

```

predicate	object
hasActivity	MoistureAnalysis
rdf:type	owl:NamedIndividual
providedBy	Sys1_AutomatedIrrigationSystem
rdf:type	IrrigationService
hasActivity	MoistureSensing
hasActivity	WaterFlow

Figure 4-4 SPARQL Query of Automated Irrigation Service

Figure 4.4 show a query od Automated irrigation system provide by Sys1_AutomatedIrrigationSystem. Autamated Irrigation has Activity of Moisture Sensing for acquiring data, has activity of Moisture Analysis than has activity Water flow for field and soil.

```

SPARQL query:
PREFIX rdf: <http://www.w3.org/1999/02/22-rdf-syntax-ns#>
PREFIX owl: <http://www.w3.org/2002/07/owl#>
PREFIX rdfs: <http://www.w3.org/2000/01/rdf-schema#>
PREFIX xsd: <http://www.w3.org/2001/XMLSchema#>
SELECT DISTINCT *

WHERE {

  <http://www.semanticweb.org/farrukh/ontologies/2019/2/untitled-ontology-11#DiseaseAndPestPredictionService> ?predicate
  ?object
}

```

predicate	object
hasActivity	DataTransmissionToCloud
rdf:type	owl:NamedIndividual
hasActivity	PredictionOfForecast
hasActivity	WindSpeedSensing
hasActivity	DewSensing
hasActivity	HumiditySensing
hasActivity	WeatherForecast
hasActivity	LiveMonitoring
hasActivity	MoistureSensing
hasActivity	ReportGenerateForFarmer
providedBy	Sys3_DiseaseAndPestPredictionSystem
hasActivity	PredictionOfDisease

Figure 4-5 SPARQL Query of DiseaseAndPestPerdictionService

Figure 4-5 query show the system and activities of Disease and Pest prediction system. This service is provided by Sys3_DiseaseAndPestPredictionSystem. The name of the activities is Moisture sensing for gathering data, Dew sensing, Humidity sensing, wind speed sensing also for data gathering. Than next activity is Data Transmission to cloud than weather forecast than prediction of forecast, next activity is prediction of pest, next generate report fir farmer and generate report for director.

SPARQL query:	
<pre> PREFIX rdf: <http://www.w3.org/1999/02/22-rdf-syntax-ns#> PREFIX owl: <http://www.w3.org/2002/07/owl#> PREFIX rdfs: <http://www.w3.org/2000/01/rdf-schema#> PREFIX xsd: <http://www.w3.org/2001/XMLSchema#> SELECT DISTINCT * WHERE { <http://www.semanticweb.org/farrukh/ontologies/2019/2/untitled-ontology-11#Moisture> ?predicate ?object } </pre>	
predicate	object
rdf:type	owl:NamedIndividual
processedBy	AnalogSignalConvertIntoDigitalSignal
processedBy	PredictionOfDisease
processedBy	MoistureAnalysis
processedBy	K-meanClusteringForAccuration
rdf:type	Observations
transmittedBy	DataTransmissionToCloud
processedBy	CombiningDataForAnalysisAndComputation
rdf:type	owl:Class
rdfs:subClassOf	WeatherData
acquireBy	MoistureSensing

Figure 4-6 SPARQL Query of Moisture

Figure 4-6 query show that Observation Moisture is acquire by Moisture Sensing. Than Moisture is transmitted by Data Transmission to cloud. Moisture processed by different activities like Moisture Analysis, K-mean clustering for accuration. Combining Data for analysis and computation, Analog Signal covert into digital signal, Prediction of Disease.

SPARQL query:	
<pre> PREFIX rdf: <http://www.w3.org/1999/02/22-rdf-syntax-ns#> PREFIX owl: <http://www.w3.org/2002/07/owl#> PREFIX rdfs: <http://www.w3.org/2000/01/rdf-schema#> PREFIX xsd: <http://www.w3.org/2001/XMLSchema#> SELECT DISTINCT * WHERE { <http://www.semanticweb.org/farrukh/ontologies/2019/2/untitled-ontology-11#Robot> ?predicate ?object } </pre>	
predicate	object
has	DcMotor
rdf:type	owl:NamedIndividual
has	UltrasonicSensor
rdf:type	Actors
has	ServoMotor

Figure 4-7 SPARQL Query of Robot

Figure 4-7 query show that Robot type is Actor. Robot has contained different machine on itself like Robot has DC Motor. Robot has Ultrasonic Sensor and Robot has Servo Motor

4.3 Reasoner based Validation

Protégé itself isn't an expert system but it is a tool that helps researchers to build ontologies to support expert systems. And for the purpose of validating the ontologies, it provides the third-party reasoners like Hermit, FaCT++ and others. Reasoners provide validation of the ontologies by knowledge discovery and by detecting and finding inconsistencies or contradictions. These reasoners are based on mathematical models. They provide logical deductions based on inferences rules defined that are specified in description logic. They either use forward chaining or backward chaining to perform inference.

We have used Hermit reasoner in our research. It is based upon hyper tableau calculus and provides reasoning for OWL based ontology files. Two types of validations exist for our approach. One is the reasoner-based validation that checks for the knowledge discovery and consistency of the classes, sub-classes and of the instances. The second one corresponds to the SPARQL validation that will prove that the requirements are defined and can be retrieved

accordingly using these queries. For the first one, i.e., reasoner-based validation, we will take some examples from our ontology to inject some inconsistencies in the definition to check whether reasoner identifies that or not.

4.4 Conclusion and Future Directions

Different Smart agriculture systems are studied which are providing a number of smart agriculture services. These services are composed of different activities. These activities perform specific tasks under the specific service. For example. Automated irrigation system provided by Automated Irrigation System. Automated Irrigation has Activity of Moisture Sensing for acquiring data, has activity of Moisture Analysis than has activity Water flow for field and soil

These systems of different agriculture applications categorized in 5 types

- Disease based IOT agriculture applications
- Monitoring based IOT agriculture applications
- Irrigation IoT agriculture application
- Harvesting IoT agriculture application
- Robotics IoT agriculture application.

All these services work in an isolation manner to entertain user in specific problem. Cohesive agriculture applications are missing. Each of these applications works on their own flow and architecture. This work includes finding certain differences and commonalities in these stand-alone applications of IOT agriculture. Depending upon these commonalities and differences an integrated architecture of different IOT agriculture applications can be developed. This cohesive architecture will provide a variety of agriculture applications to the users under one umbrella.

To achieve this goal theoretically, we have adopted the ontology engineering methodology. We have formally defined 21 systems on the ontology providing the services and activities of each service individually. Once the ontology for each system is defined, an integrated ontology for cohesive smart health system is designed based on ontology engineering principles. This cohesive ontology is then verified by defining different use cases. Different services of different smart agriculture system are utilized to ensure the cohesiveness of this

system. We have not worked on the physical infrastructure of all the systems and it will be a vital future direction to work on the physical infrastructure of different agriculture systems in combination with the formal definition of the systems shown by the ontology engineering.



Chapter 5 **References**

- 
- [1] Jan Holler et al, "Introduction to a New Age of Intelligence," in *Machine-to-Machine to the Internet of Things*, 1st ed. London, Academic Press Ltd, 2014.
- [2] A. M. Alberti, G. D. Scarpioni, V. J. Magalhaes and S. A. Cerqueira, "Advancing Nova Genesis architecture towards future Internet of Things," *IEEE Internet Things J.*, 2018.
- [3] Vandana Sharma and Ravi Tiwari, "A review paper on "IOT" & It's Smart," in *International Journal of Science, Engineering and Technology Research (IJSETR)*, 2016.
- [4] Sommayya Madakam, R. Ramaswamy and Siddharth Tripathi, "Internet of Things (IoT): A Literature Review," *Journal of Computer and Communications*, pp. 164-173, 2016.

- [5] Dave Evans, "The Internet of Things: How the Next Evolution of the Internet Is Changing Everything," in *Internet Business Solutions Group (IBSG), Cisco Systems, Inc., San Jose, CA, USA, White Paper*, 2011.
- [6] Mohamed Ali Feki, Fahim Kawsar, Mathieu Boussard and Lieven Trappeniers, "The Internet of Things: The Next Technological Revolution," in *ieeexplore.ieee.org*, 2013.
- [7] Keyur K Patel and Sunil M Patel, "Internet of Things-IOT: Defination, Characteristics,Architecture,Enabling Technologies,Application & Future Challanges," *ISSN 2321 3361 IJESC*, vol. 6, 2016.
- [8] Suyash S. Patil and Sandeep A. Thorat, "Early Detection of Grapes Diseases Using Machine Learning and IoT," in *Second International Conference on Cognitive Computing and Information Processing (CCIP)*, 2016.
- [9] Heamin Lee, Aekyung Moon, Kiyeong Moon and Youngjae Lee, "Disease and Pest Prediction IoT System in Orchard," in *Ninth International Conference on Ubiquitous and Future Networks (ICUFN)*, Milan, 2017.
- [10] Mr. Kunal Sonawane, Mr. Abhishek Patil and Mr. Sandesh Nikam, "Intelligent fertilizers & pesticide advisory system using IOT and android," in *International Journal for Research in Engineering Application & Management (IJREAM)*, 2018.
- [11] Yun Shi, Zhen Wang, Xianfeng Wang and Shanwen Zhang, "Internet of Things Application to Monitoring Plant Disease and Insect Pests," in *International Conference on Applied Science and Engineering Innovation*, 2015.
- [12] Dr.G.Rajakumar, M.Saroja Sankari, D.Shunmugapriya and S.P.Uma Maheswari, "Iot Based Smart Agricultural Monitoring System," *Asian Journal of Applied Science and Technology (AJAST)*, vol. 2, p. 474, 2018.
- [13] Kajol R, Akshay Kashyap K and Mr. Keerthan Kumar T G, "Automated Agricultural Field Analysis and Monitoring System Using IOT," in *I.J. Information Engineering and Electronic Business*, 2018.
- [14] Rajalakshmi.P and Mrs.S.Devi Mahalakshmi, "IOT Based Crop-Field Monitoring And Irrigation Automation," in *IEEE*, 2016.

- [15] Ciprian-Radu RAD, Olimpiu HANCU and Ioana-Alexandra, "Smart Monitoring of Potato Crop: A Cyber-Physical System Architecture Model in the Field of Precision Agriculture," in *ST26733 International Conference "Agriculture for Life, Life for Agriculture"*, 2015.
- [16] K.Lakshmi and S.Gayathri, "Implementation of IoT with Image processing in plant growth monitoring system," in *Journal of Scientific and Innovative Research*, 2017.
- [17] Abdullah Na, William Isaac, Shashank Varshney and Ekram Khan, "An IoT Based System for Remote Monitoring of Soil Characteristics," in *INCITE-The Next Generation*, 2016.
- [18] Xueyan Zhang, Jianwu Zhang, Lin Li, Yuzhu Zhang and Guocai Yang, "Monitoring Citrus Soil Moisture and Nutrients Using an IoT Based System," in *MDPI*, 2017.
- [19] C.Kishore Kumar and Veeramuth Venkatesh, "Cloud based soil monitoring and smart irrigation system using IoT and precision farming," *International Journal of Pure and Applied Mathematics*, vol. 119, p. no.18, 2018.
- [20] Vaishali S, Suraj S, Vignesh G, Dhivya S and Udhayakumar S , "Mobile Integrated Smart Irrigation Management and Monitoring System Using IOT," in *IEEE-International Conference on Communication and Signal Processing*, India, 2017.
- [21] Dweepayan Mishra, Arzeena Khan, Rajeev Tiwari and Shuchi Upadhyay, "Automated Irrigation System-IoT Based Approach," in *IEEE*, 2018.
- [22] P. Divya Vani and K. Raghavendra Rao, "Measurement and Monitoring of Soil Moisture using Cloud IoT and Android System," *Indian Journal of Science and Technology*, vol. 9, p. no.2, 2017.
- [23] C. Roussey, V. Soullignac, J. Champomier and C. Abt, "Ontologies in Agriculture," in *International Conference on Agricultural Engineering*, 2010.
- [24] G. Parameswaran and K.Sivaprasath, "Arduino Based Smart Drip Irrigation System Using Internet of Things," *IJESCI*, vol. 6, p. no. 5, 2015.

- [25] Mr. V. Gowrishankar and Dr. K. Venkatachalam , "IoT Based Precision Agriculture using Agribot," *GRD Journals- Global Research and Development Journal for Engineering*, vol. 3, no. 5, pp. 2455-5703, April 2018.
- [26] AmarendraGoap, DeepakSharma, A.K.Shukla and C.RamaKrishna, "An IoT based smart irrigation management system using Machine learning and open source technologies," *Elsevier.ComputersandElectronicsinAgriculture*, no. 27September2018, pp. 41-49, 2018.
- [27] Amrita Sneha.A, Abirami.E, Ankita.A, Mrs.R.Praveena and Mrs.R.Srimeena, "Agricultural Robot for Automatic Ploughing and Seeding," in *IEEE International Conference on Technological Innovations in ICT for Agriculture and Rural Development* , 2015.
- [28] Tanmayee.P , "Rice Crop Monitoring System - A Iot Based Machine Vision Approach," in *IEEE*, 2017.
- [29] Li Biqing, Ling Yongfa, Zhang Hongyan and Zheng S, "The Design and Realization of Cherry Tomato Harvesting Robot Based on IOT," *iJOE*, vol. 12, no. 12, 2016.
- [30] Naik Durgesh Manikrao and Dr. Prof. A.J.Vyavahare, "Disease Detection of Cotton crop using Image Processing Technique," *International Journal for Research in Applied Science & Engineering Technology (IJRASET)*, vol. 3, no. IV, 2015.
- [31] Mr. P. S. Chopade and Mr. S. A. Korde , "Disease Prediction on Plants with the Helps of IOT," *International Journal on Recent and Innovation Trends in Computing and Communication*, vol. 5, no. 11, pp. 212-218, November 2017.
- [32] SRAVANTHI SAVANAM and B. P. V. SUBBA RAO, "Leaf disease Detection and Climatic Parameter Monitoring of Plants Using IoT," *International Journal of Management, Technology And Engineering*, vol. 9, no. 1, pp. 3002-3006, January 2019.
- [33] V.Narendran , Lewis Edberg C.P. and Dr G. Meera Gandhi, "Autonomous Robot for E-farming Based on Fuzzy Logic Reasoning,"

International Journal of Pure and Applied Mathematics , vol. 118, pp. 3811-3821, 2018.

- [34] M.ARUN, R.PRATHIPA, PRIYANKA S and AKSHAYA ANAND, "SMART AGRICULTURE ROBOT," *International Journal of Pure and Applied Mathematics* , vol. 119, no. 15, pp. 1901-1906, 2018.



APPENDIX-I

System	Participants	Transactions (Services)	Data
SYS 1 [24]	<ul style="list-style-type: none"> • Wireless Sensor Network • Water Pump • Soil 	<p>Automated Irrigation System</p> <ul style="list-style-type: none"> • Data Acquisition <ul style="list-style-type: none"> ○ Moisture Sensing • Data Analysis <ul style="list-style-type: none"> ○ Measure moisture • Water Flow 	<p>Moisture</p> <p>Unit: cubic meter</p>
SYS 2 [20]	<ul style="list-style-type: none"> • Farmer • Android App • Digital System • Wireless Sensor Network • Soil 	<p>Mobile Irrigation System</p> <ul style="list-style-type: none"> • Data Acquisition <ul style="list-style-type: none"> ○ Moisture Sensing • Analog Signal Convert into Digital Signal • Data Analysis <ul style="list-style-type: none"> ○ Measure Moisture • Generate Alarming Message 	<p>Moisture</p> <p>Unit: cubic meter</p>
SYS 3 [11]	<ul style="list-style-type: none"> • Farmer • Investigation System • Land Environment • Weather Center • Web Application 	<p>Monitoring Plant Disease and Insect Pest</p> <ul style="list-style-type: none"> • Data Acquisition <ul style="list-style-type: none"> ○ Environment signal • Investigation of tiny insects • Detect insect migration path • Data transmission • Gis Forecast • Early warning • Insect population Dynamics • Statically Model for prediction crop disease 	<p>Environment Signal</p>
SYS 4 [19]	<ul style="list-style-type: none"> • Soil • Pump • Wireless Sensor Network 	<p>Smart Irrigation Monitoring System</p> <ul style="list-style-type: none"> • Data Acquisition <ul style="list-style-type: none"> ○ Moisture Sensing • Data Analysis <ul style="list-style-type: none"> ○ Measure moisture • Decision Making <ul style="list-style-type: none"> ○ Pump on Off 	<p>Moisture</p> <p>Unit: cubic meter</p>
SYS 5 [15]	<ul style="list-style-type: none"> • Soil • App and Services • Farmer • Wireless Sensor Network 	<p>Smart Monitoring of Potato Crop</p> <ul style="list-style-type: none"> • Data Acquisition 	<p>Moisture</p>

		<ul style="list-style-type: none"> ○ Moisture Sensing ○ Acidity Sensing ○ Nitrogen Sensing ○ Potassium Sensing ○ Phosphorous Sensing ○ Chlorophyll Sensing ● Data Transmission <ul style="list-style-type: none"> ○ Access and Transmit Information to Cloud ● Decision Layer <ul style="list-style-type: none"> ○ Soil Resource Data ○ Vegetation State Data ○ Pedo and Agrodem Data ● Dedicate app and services 	Unit: cubic meter Acidity Unit: pH Nitrogen Potassium Phosphorus Chlorophyll
SYS 6 [12]	<ul style="list-style-type: none"> ● Soil ● Wireless Sensor Network ● Spray ● Water Tap 	<p>Smart Agricultural Monitoring</p> <ul style="list-style-type: none"> ● Data Acquisition <ul style="list-style-type: none"> ○ Moisture Sensing ○ Temperature Sensing ○ Humidity Sensing ● Data Transmission to Cloud <ul style="list-style-type: none"> ○ Soil Data ○ Temperature Data ○ Water Data ● Action Performed <ul style="list-style-type: none"> ○ Spray ○ Water Tap on and off 	Moisture Unit: cubic meter Temperature Unit: Celsius Humidity Unit: Percentage Water Salt

<p>SYS 7 [14]</p>	<ul style="list-style-type: none"> • Soil • Web Application • Tap • Bulbs • Wireless Sensor Network 	<p>Crop Monitoring and Irrigation Automation</p> <ul style="list-style-type: none"> • Data Acquisition <ul style="list-style-type: none"> ○ Soil Moisture Sensing ○ Temperature Sensing ○ Light Sensing • Wireless Data Transmission <ul style="list-style-type: none"> ○ Transmitted Data to webserver • Analyzing Data <ul style="list-style-type: none"> ○ Web application analyses Data • Action Performed <ul style="list-style-type: none"> ○ Irrigation ○ Light Control 	<p>Moisture</p> <p>Unit: cubic meter</p> <p>Temperature</p> <p>Unit: Celsius</p> <p>Light</p>
<p>SYS 8 [13]</p>	<ul style="list-style-type: none"> • Field • Crop • Robot • Android Application 	<p>Automated Agriculture Field Analysis and Monitoring System</p> <ul style="list-style-type: none"> • Data Acquisition <ul style="list-style-type: none"> ○ Images of Crops • Data Transmission <ul style="list-style-type: none"> ○ Data Upload on cloud • Report Generate <ul style="list-style-type: none"> ○ Average Moisture ○ Pest attacking the crop ○ Pesticide for the crop 	<p>Crops Image</p>
<p>SYS 9 [16]</p>	<ul style="list-style-type: none"> • Soil • Plants • Webcam • Farmer • Pump • LCD • GSM Modem 	<p>Implementation of IOT with Image Processing in Plant Growth</p> <ul style="list-style-type: none"> • Information Gathering <ul style="list-style-type: none"> ○ Image of plants through webcam ○ Humidity Sensing ○ Temperature Sensing • Data Analysis <ul style="list-style-type: none"> ○ Combining data for analysis and computation ○ Report Send to Farmer • Result <ul style="list-style-type: none"> ○ Pump on Of ○ LCD Display ○ Information to Farmer 	<p>Temperature</p> <p>Unit: Celsius</p> <p>Humidity</p> <p>Unit: - Percentage</p> <p>Image of Plant</p>

<p>SYS 10 [8]</p>	<ul style="list-style-type: none"> • Grape Vineyard • Web Application • Wireless Sensor Network • Arduino (Analog System) • Zig-Bee Network 	<p>Early Detection Grapes Disease</p> <ul style="list-style-type: none"> • Data Acquisition <ul style="list-style-type: none"> ○ Temperature Sensing ○ Humidity Sensing ○ Moisture Sensing • Convert Analog Signal into Digital Signal • Data Transmission <ul style="list-style-type: none"> ○ Transfer Data to Cloud using Zig-Bee ○ Data Store in Database • Calculating Euclidean Distance. • Report <ul style="list-style-type: none"> ○ State Transition Probability 	<p>Temperature Unit: Celsius</p> <p>Humidity Unit: Percentage</p> <p>Time Unit: Hour</p>
<p>SYS 11 [9]</p>	<ul style="list-style-type: none"> • Weather Station • Soil • Prediction System for Disease & Pest • Prediction System for Forecast Monitoring System • Android Application for farmer • Web Application for Directors • Wireless Network System • Cloud 	<p>Disease and Pest Prediction System in Orchard</p> <ul style="list-style-type: none"> • Data Acquisition <ul style="list-style-type: none"> ○ Weather Forecast (Weather Station) ○ Moisture Sensing (WSN) ○ Humidity Sensing (WSN) ○ Dew Sensing (WSN) ○ Wind Sensing (WSN) • Data Transmission (Cloud) • Prediction of Forecast (Prediction System for Forecast) • Prediction of Pest (Prediction System for Disease & Pest) • Prediction of Disease (Prediction System for Disease & Pest) • Live Monitoring (Monitoring System) • Report Generate for Farmer (Android Application) • Report Generate for Directors (Web Application) 	<p>Video</p> <p>Weather Forecast</p> <p>Moisture Unit: - cubic meter</p> <p>Humidity Unit: - Percentage</p> <p>Dew</p> <p>Wind Velocity Direction</p>
<p>SYS 12 [25]</p>	<ul style="list-style-type: none"> • Robot • Web Browser 	<p>Precision Agriculture using Agribot</p> <ul style="list-style-type: none"> • Command from Web Browser 	<p>Soil</p>

		<ul style="list-style-type: none"> • Ploughing Through robot • Seed Sowing • Pesticide Spray • Solenoid Value (Irrigation) 	<p>Seed</p> <p>Spray</p>
SYS 13 [26]	<ul style="list-style-type: none"> • Soil • Application for User • Water Tap • Web service for Weather forecast • Monitoring System • Wireless Sensor Network 	<p>Smart Irrigation Management System With Machine Learning and Open Source Technology</p> <ul style="list-style-type: none"> • Data Acquisition <ul style="list-style-type: none"> ○ Moisture Sensing ○ Air Temperature Sensing ○ Humidity Sensing ○ Soil Temperature Sensing • Weather data (Web Application) <ul style="list-style-type: none"> ○ Moisture ○ Temperature ○ Humidity ○ UV ○ Precipitation • Develop Support Vector Regression Model <ul style="list-style-type: none"> ○ Prediction of soil moisture of upcoming days • K-mean clustering Accuration • Final predicted soil Moisture • Start and stop irrigation • Live Monitoring of irrigation 	<p>Moisture</p> <p>Unit: - cubic meter</p> <p>Air Temperature</p> <p>Unit: - Celsius</p> <p>Humidity</p> <p>Unit: - Percentage</p> <p>Ultra Violet UV</p> <p>Soil Temperature</p> <p>Unit: - Celsius</p> <p>Weather forecast</p>
SYS 14 [27]	<ul style="list-style-type: none"> • Robots • Field • Bluetooth • LCD • GSM • Water Sprinkle 	<p>Agricultural Robot for Automatic Ploughing and Seeding</p> <ul style="list-style-type: none"> • Robot Move (Ultrasonic Sensor) • Field Display (LCD) 	<p>Seed</p>

	<ul style="list-style-type: none"> • Camera • Farmer • AVR • Ultrasonic Sensor • Servo motor • DC Motor • Wireless Sensor Network 	<ul style="list-style-type: none"> • Field Tiller (Servo Motor) • Distributed Seed (DC Motor) • Data Acquisition <ul style="list-style-type: none"> ◦ Humidity Sensing (WSN) • Convert Data Analog to Digital image • Humidity Display (LCD) • Send Message to Farmer (GSM) • Farmer Command (GSM) <ul style="list-style-type: none"> ◦ Water Sprinkle on Off 	Soil Humidity Unit: - Percentage
SYS 15 [28]	<ul style="list-style-type: none"> • Rice Crop • DC Motor • Camera • Raspberry Pi • Android Application 	Rice Crop Monitoring System <ul style="list-style-type: none"> • Video Streaming of Rice Crop (Camera) • Detection of Infected Area <ul style="list-style-type: none"> ◦ Captured image of Rice Crop • Location of Infected Area (Raspberry Pi) <ul style="list-style-type: none"> ◦ Feature Extraction (Color Filter) ◦ Image Enhancement (removal of noise through Morphological) ◦ Calculate Momentum ◦ Display coordinate in x and y • Report generate (Android Application) 	Image of Rice Crop Start Temperature: - 24 to 30 Time of Harvest: - 30 to 40 degree
SYS 16 [29]	<ul style="list-style-type: none"> • Cherry Tomato Crop • Robot (Manipulator) • PLC Control Technology • Camera • Cloud • Mat lab 	Cherry Crop Tomato Harvesting Robot Based on Internet of things <ul style="list-style-type: none"> • Manipulator Close to Target (Robot) • Image Collector (Camera) • Image Transmission to Cloud • Image identification <ul style="list-style-type: none"> ◦ Image Binary Processing ◦ Dilation Processing ◦ Erosion Processing ◦ Identification Fruit Maturity • PLC Robot Harvest Fruit <ul style="list-style-type: none"> ◦ Compute the angle of harvesting ◦ Outputting the angle ◦ Harvesting 	Image of Tomato Crop
SYS 17 [30]	<ul style="list-style-type: none"> • User (Farmer) • Camera • SVM (Support Vector Machine) 	IoT and Image Processing used for Cotton Disease Detection <ul style="list-style-type: none"> • Image Acquisition 	Image of Cotton Crop

		<ul style="list-style-type: none"> ○ Color Image Capture (Camera) ● Image Pre-Processing <ul style="list-style-type: none"> ○ Remove Distortion ○ RGB image transform into Hue saturation ● Image Segmentation ● Feature Extraction ● Classification Through SVM (Support Vector Machine) ● Disease Detection Through Artificial Neural Network (ANN) 	
SYS 18 [31]	<ul style="list-style-type: none"> ● Rice Crop ● Weather Data Acquisition System ● Wireless Sensor Network ● Web Service System ● User ● Wireless Network Sensor 	<p>Disease Prediction on Plants with the Helps of IOT</p> <ul style="list-style-type: none"> ● Data Acquisition (WSN) <ul style="list-style-type: none"> ○ Moisture Sensing ○ Temperature Sensing ○ Humidity Sensing ● Metrological Dataset <ul style="list-style-type: none"> ○ 30 Days data of Moisture, temperature, Humidity ● Use Data Mining Method for Prediction of Disease <ul style="list-style-type: none"> ○ Cluster Analysis ○ K- Mean Clustering ○ Hierarchical Clustering ● Report Generate (User) 	Moisture Temperature Humidity Weather Prediction
SYS 19 [32]	<ul style="list-style-type: none"> ● Grape Leaf ● Web Application ● Camera ● Zig Bee Network ● Mat lab ● Arduino 	<p>Leaf Disease detection and climate monitoring of Plant</p> <ul style="list-style-type: none"> ● Image Capturing ● Climate Sensing ● Leaf Image Segmentation ● Actual Leaf Region Segmentation ● Leaf Disease Region Segmentation <ul style="list-style-type: none"> ○ Combine with Climate Data ● Send Result on Web Application 	Image of Grape Leaf Temperature (Climate)
SYS 20 [33]	<ul style="list-style-type: none"> ● User ● Robot ● Mobile App ● Cloud ● Raspberry Pi Model ● Arduino Uno ● Servo motors ● DC Motors ● Battery ● Motor Driver DHT11 Sensor ● IR Sensor 	<p>Autonomous Robot for E-farming Based on Fuzzy Logic Reasoning</p> <ul style="list-style-type: none"> ● User Command Through Mobile App ● Cloud Send Input from User to Robot ● Arduino Uno control Fuzzy Based Line Follower ROBOT ● The DHT11 sensor Check Humidity Air ● Robot Movement (DC Motor) ● Robot Watering (DC Motor) ● Ploughing (DC Motor) 	Soil Moisture Temperature

		<ul style="list-style-type: none"> • Seeding (Servo Motor) • Cloud Receive Input from Robot • User Receive Output from Robot via Cloud 	
SYS 21 [34]	<ul style="list-style-type: none"> • Robot • Field • Wireless Sensor Network (WSN) • Pump • Wi-Fi • Arduino • User • Ultrasonic Sensor • Servo Motor 	<p>SMART AGRICULTURE ROBOT</p> <ul style="list-style-type: none"> • Obstacle Detection In Field (Ultrasonic Sensor) • Temperature Sensing (WSN). • Ploughing <ul style="list-style-type: none"> ○ Ploughing Tool is interfaced with Arduino ○ Ploughing tool operated three modes on, off and mid • Seed Sowing <ul style="list-style-type: none"> ○ Seeds stored in container ○ Servomotor Open and Close Container • WATERING <ul style="list-style-type: none"> ○ The temperature sensor interfaced with the Arduino send detail through Wi-Fi module ○ Water Pouring in Field ○ Solenoid valve to Allow and stop water to the field. • OBSTACLE DETECTION AND CLEARANCE <ul style="list-style-type: none"> ○ Ultrasonic Sensor used for obstacle detection ○ After detection, robot automatically stops ○ Obstacle Clearance tool break Obstacles 	<p>Ploughing</p> <p>Seeding</p> <p>irrigation (Water)</p> <p>Temperature</p> <p>Moisture</p>