

SUPERIOR UNIVERSITY LAHORE



Faculty of Computer Science & IT

Final Year Project PROJECT REPORT

CMAH Web App

Project ID: **BSCS-FYP-F18-011**

Project Team

Student Name	Student ID	Program	Contact Number	Email Address
Ihtasham Akram	BCSM-F15-093	BSCS	03314602138	Ihtashamakram786@gmail.com
Faizan ul Haq	BCSM-F15-002	BSCS	03360690539	dfaizanshah@gmail.com
Munazza Tahir	BCSM-F15-078	BSCS	03379689696	Munazzatahir6966@gmail.com

Project Supervisor

Mam Faiqa Maqsood

Project Report

CMAH Web App

Change Record

Author(s)	Version	Date	Notes	Supervisor's Signature
	1.0		<Original Draft>	
			<Changes Based on Feedback from Supervisor>	
			<Changes Based on Feedback From Faculty>	
			<Added Project Plan>	
			<Changes Based on Feedback from Supervisor>	

APPROVAL

PROJECT SUPERVISOR

Comments: _____

Name: _____

Date: _____ Signature: _____

PROJECT MANAGER

Comments: _____

Date: _____ Signature: _____

HEAD OF THE DEPARTMENT

Comments: _____

Date: _____ Signature: _____

Dedication

I dedicated this project to my Parents who have been a great source of inspiration and support. This project is also dedicated to mam Faiqa Maqsood a great Teacher & a leader who encourages us to build our motivation.

Acknowledgements

All gestures of recognition are to Almighty of Allah, who gave us the quality, Learning and bravery to finish this errand. We might want to pay huge amounts of thanks and offer my regards to our Supervisor Mam Faiqa Maqsood for her valuable direction, advises and support all through the learning procedure that she gave me a helpful course to finish our venture.

Executive Summary

We are creating platform where a patient or person can get information about diseases and their basic medication. There is also a platform where patient and doctor can login; doctor can give appointment to patient.It will also help to get online appointment. Doctor's information will be arranged according to their specialization. Through image Prescription, patient can send report or photo to doctor and get prescription.

Table of Contents

Dedication	iv
Acknowledgements.....	v
Executive Summary.....	vi
Table of Contents	vii
List of Figures	Error! Bookmark not defined.
List of Tables	Error! Bookmark not defined.
Chapter 1.....	1
Introduction	1
1.1. Background.....	2
1.2. Motivations and Challenges.....	3
1.3. Goals and Objectives.....	3
1.4. Literature Review/Existing Solutions	4
1.5. Gap Analysis	5
1.6. Proposed Solution	5
1.7. Project Plan	6
1.7.1. Work Breakdown Structure.....	7
1.7.2. Roles & Responsibility Matrix.....	8
1.7.3. Gantt Chart	9
1.8. Report Outline.....	9
Chapter 2.....	10
Software Requirement Specifications	10
2.1. Introduction.....	11
2.1.1. Purpose.....	11
2.1.2. Document Conventions	11
2.1.3. Intended Audience and Reading Suggestions	12
2.1.4. Product Scope.....	12
2.1.5. References	12
2.2. Overall Description.....	13
2.2.1. Product Perspective.....	13
2.2.2. Product Functions.....	13
2.2.3. User Classes and Characteristics	14
2.2.4. Operating Environment.....	14
2.2.5. Design and Implementation Constraints.....	15
2.2.6. User Documentation	15
2.2.7. Assumptions and Dependencies	15
2.3. External Interface Requirements	16
2.3.1. User Interfaces.....	16
2.3.2. Hardware Interfaces.....	16
2.3.3. Software Interfaces	16
2.3.4. Communications Interfaces.....	16
2.4. System Features	17
2.4.1. System Feature 1	18

2.4.1.1.	Description and Priority	Error! Bookmark not defined.
2.4.1.2.	Stimulus/Response Sequences	Error! Bookmark not defined.
2.4.1.3.	Functional Requirements.....	Error! Bookmark not defined.
2.4.2.	System Feature 2	Error! Bookmark not defined.
2.4.2.1.	Description and Priority	Error! Bookmark not defined.
2.4.2.2.	Stimulus/Response Sequences	Error! Bookmark not defined.
2.4.2.3.	Functional Requirements.....	Error! Bookmark not defined.
2.4.3.	System Feature 3 (and so on).....	Error! Bookmark not defined.
2.5.	Other Nonfunctional Requirements	34
2.5.1.	Performance Requirements	34
2.5.2.	Safety Requirements	34
2.5.3.	Security Requirements	34
2.5.4.	Software Quality Attributes.....	34
2.5.5.	Business Rules.....	35
2.6.	Other Requirements.....	35
Chapter 3.....		37
Use Case Analysis.....		37
3.1.	Use Case Model.....	39
3.2.	Use Case Descriptions	Error! Bookmark not defined.
Chapter 4.....		40
System Design.....		40
4.1.	Architecture Diagram	41
4.2.	Domain Model.....	42
4.3.	Entity Relationship Diagram with data dictionary	43
4.4.	Class Diagram	44
4.5.	Sequence / Collaboration Diagram	45
4.6.	Operation contracts	45
4.7.	Activity Diagram	49
4.8.	State Transition Diagram.....	52
4.9.	Component Diagram	53
4.10.	Deployment Diagram.....	54
4.11.	Data Flow diagram [only if structured approach is used - Level 0 and 1].....	55
Chapter 5.....		58
Implementation		58
5.1.	Important Flow Control/Pseudo codes.....	59
5.2.	Components, Libraries, Web Services and stubs	60
5.3.	Deployment Environment	60
5.4.	Tools and Techniques.....	60
5.5.	Best Practices / Coding Standards.....	61
5.6.	Version Control	61
Chapter 6.....		62
Testing and Evaluation.....		62
6.1.	Use Case Testing.....	Error! Bookmark not defined.
6.2.	Equivalence partitioning	Error! Bookmark not defined.

6.3. Boundary value analysis.....	72
6.4. Data flow testing.....	72
6.5. Unit testing.....	73
6.6. Integration testing.....	73
6.7. Performance testing.....	73
6.8. Stress Testing.....	73
Chapter 7.....	Error! Bookmark not defined.
Summary, Conclusion and Future Enhancements.....	Error! Bookmark not defined.
7.1. Project Summary.....	Error! Bookmark not defined.
7.2. Achievements and Improvements.....	Error! Bookmark not defined.
7.3. Critical Review.....	Error! Bookmark not defined.
7.4. Lessons Learnt.....	Error! Bookmark not defined.
7.5. Future Enhancements/Recommendations.....	Error! Bookmark not defined.
Appendices.....	74
Appendix A: User Manual.....	Error! Bookmark not defined.
Appendix B: Administrator Manual.....	Error! Bookmark not defined.
Appendix C: Information / Promotional Material.....	Error! Bookmark not defined.
Reference and Bibliography.....	74
Index.....	Error! Bookmark not defined.

List of Figures

1.1	Caption of first figure of first chapter	6
1.2	Caption of second figure of first chapter	7
2.1	Caption of first figure of second chapter	14
2.2	Caption of second figure of second chapter	22
2.3	Caption of third figure of second chapter	26
5.1	Caption of first figure of fifth chapter	49
5.2	Caption of second figure of fifth chapter	49

List of Tables

1.1	label of first table of first chapter	6
1.2	label of second table of first chapter	7
2.1	label of first table of second chapter	14
2.2	label of second table of second chapter	22
2.3	label of third table of second chapter	26
5.1	label of first table of fifth chapter	49
5.2	label of second table of fifth chapter	49

Chapter 1

Introduction

Chapter 1:

Introduction

We are developing a Web Based Application with some amazing features. The main idea is that it is a Web Base application named as CMAH helps the patients in taking online appointments, diagnosis through image prescription, doctors list for appointment, finding doctors' profile. The basic reason for this task is to help the patient to effortlessly look for information about diseases and take online appointments. This framework causes the patient to decrease its search time, all things considered, by enabling the patient to enter its medical problems and inquire in like manner.

1.1. Background

Now a days, technology has changed life style of people. IT has so much facilitated people, they can buy products without going to some places and spending time. In Pakistan, government hospitals are overcrowded. People feel irritated in hospitals. They can't get a proper time and care by doctors. With that, hospitals in Pakistan don't have that much proper website to facilitate patients. There are few website that have functionalities appointment online. But overall, there is not any proper hospital website in Pakistan. No information about diseases, there preventions or health tips are available on hospital website. CMAH will be an innovative feature in a hospital website.

1.2. Motivations and Challenges

We witnessed that due to a huge crowd, people don't get proper time from doctors. Those people who have come from far areas like from southern Punjab to Lahore and they are not treated the way they should be treated. So it motivated us to have a web app so people can save their time without traveling long distance through Image Prescription .The biggest challenge is that people don't have awareness about hospital websites. That is because there isn't any proper response in Hospital Websites in Pakistan.

1.3. Goals and Objectives

Goal

The main idea is that it is a Web Base application named as CMAH helps the patients in taking online appointments, diagnosis through image prescription, doctors list for appointment, finding doctors' profile.

Time and Energy efficiency:

A person can search information by sitting at home. One can also take appointment and also send diseased part photo to doctor for image prescription. That can save time and Energy.

Accessibility:

An individual by sitting at their home can get appointment, get medicine details, E-Prescription through image prescription.

1.4. Literature Review/Existing Solutions

Most frequently people went online to look up information about a specific disease or medical problem (63 percent) or a particular medical treatment or procedure (47 percent). They were also interested in diet, nutrition and vitamins (44 percent) and exercise or fitness information (36 percent). Other popular health topics include: prescription or over-the-counter drugs (34 percent); alternative treatments (28 percent); health insurance (25 percent); depression, anxiety or stress (21 percent) and a particular doctor or hospital (21 percent).

The new study indicates that looking for health or medical information is one of the most popular activities online. Only e-mail, which is used by 93 percent of the Internet population, and researching a product or service before purchase, 83 percent of users, top it. “We wanted to get at the diversity of the topics being researched,” says Susannah Fox, Pew’s director of research. “It tells us that people are turning to the Internet to make better decisions in their lives, whether buying a book or making a health decision.”

Existing System

In Pakistan, hospitals have website but they are not much efficient. As a result of which people don’t have any interest in them. But there also exist website of hospitals like Ali Medical Center, Shifa International etc. which are comparatively better than others. But still they are not that much responsive. We will make our web app efficient and it will be helpful for patients.

1.5. Gap Analysis

GAP ANALYSIS		
Desire State	Current State	Actions Steps
We will make the percentage for search information about disease up-to 87 %	Most frequently people went online to look up information about a specific disease or medical problem (63 percent) or a particular medical treatment or procedure (47 percent).	For the boost in percentage we will aware people about online search and how online search can save their time and money.

1.6. Proposed Solution

We proposed a solution for this problem, by doing some Experiments:

- We have to create a web base Application.
- E-Prescription
- Information about disease
- Information of Doctors
- Doctor will set appointment according to his Timetable.

1.7. Project Plan

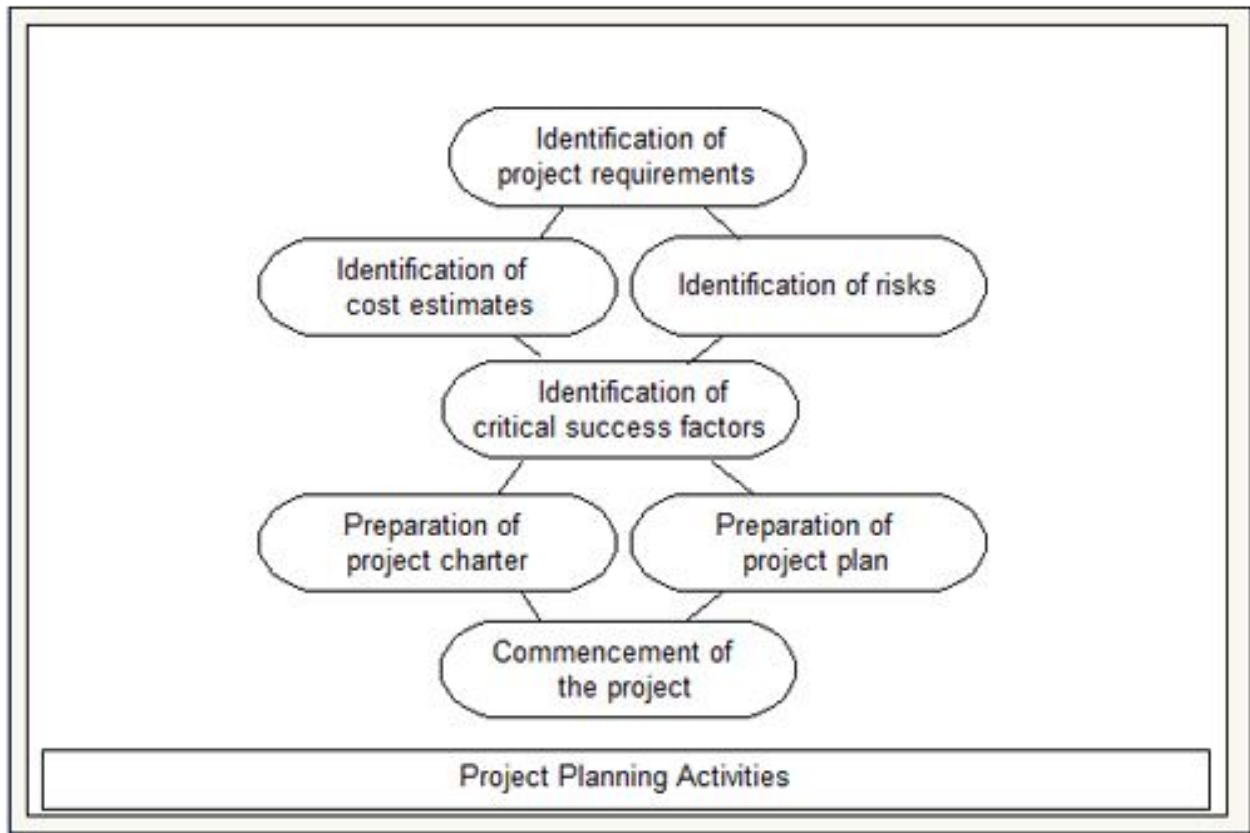

1.7.1. Work Breakdown Structure

2. Project Schedule	DEC-2018		January-2019		February-2019		March-2019		April-2019		May-2019			June-2019		July-2019		Summary	
	W3	W4	W1	W2	W1	W2	W3	W4	W1	W2	W1	W2	W3	W2	W3	W2	Hours	Percent	
Requirements	12	12	8	6													38	14.90%	
Design			4	6	12	8	3										33	13.20%	
Code & Unit Test					4	3	8	9	8	8	4	5	3	4	5		61	22.20%	
Integrate Test					2	2	2	3	13	11	3	4	5	2	3		50	21.10%	
Write User's Manual										6	2	2	3				13	6.60%	
Report writing			6	6	7	6	1	1	2	12		12	2	8	9		100	20.20%	
Demonstrate															7		7	1.90%	
Hours	12	12	18	18	25	29	25	24	21	25	9	23	23	14	17	7	302	100.00%	

Table 1.1-Workbreak Down structure

2.1.1. Roles & Responsibility Matrix

WBS	WBS Deliverable	Activity #	Activity to Complete the Deliverable	Duration (# of Days)	Responsible Team Member
1.	Planning	Proposal	Proposal Defense	15 days	All Member
2.	Design	Assets	Setup	1 month	Ihtasham Faizan
3.	Coding	PHP, Sql CSS+HTML	Scripting	2 months	All Member
4.	Designing Structure	Structure	Structure	20 days	Ihtasham Faizan
5.	Testing and debugging	website Test	Testing the website	15 days	Ihtasham Faizan
6.	Implementation	Implement Website	Develop the Website	20 days	Ihtasham Faizan
7.	Documentation	Report	Making Report	20 days	All Member

Table 1.2-Roles and Responsibilities

2.1.2. Gantt Chart

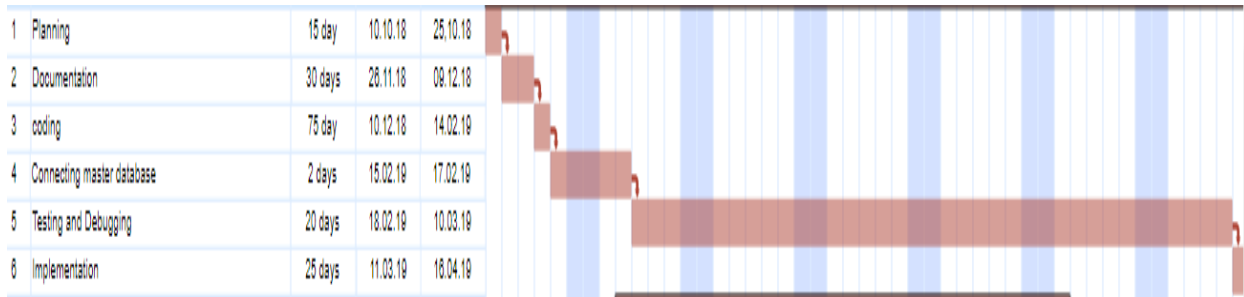

2.2. Report Outline

We are developing a web Based Application with some amazing features. The main idea is that it is a Web Base application named as **CMAH** helps the patients in taking online appointments, diagnosis through image prescription, doctors' list for appointment doctors' profile, medicine details. The basic reason for this task is to help the patient to effortlessly look for information about diseases and take online appointments. This framework causes the patient to decrease its search time, all things considered, by enabling the patient to enter its medical problems and inquire in like manner.

Chapter 2

Software Requirement Specifications

Chapter 2: Software Requirement Specifications

3.1. Introduction

We are creating platform where a person can search about disease. Also information about disease. There will be an online appointment it but will be limited per day.

Following are the functionalities of our web application.

- E-Prescription
- Basic Medication of disease
- Information about Diseases
- Information of Doctors

3.1.1. Purpose

The motivation behind this web application is to facilitate patients and saving their time.

3.1.2. Document Conventions

Standard rule of documentation has been followed in the order of standardized the work. In order to create efficient CMAH Web Application in the premises of Hospital Website.

3.1.3. Intended Audience and Reading Suggestions

This report is for individuals like engineer, client, venture chief, database staff designer.

3.1.4. Product Scope

Our web app will be very useful for patients. They can easily get online appointment, take online prescriptions via Image Prescription. They can search and view profiles of doctors and select them for appointment.

Following functions will be available in our website.

- E-Prescription
- Basic Medication of disease
- Information about Diseases
- Information of Doctors

3.1.5. References

- IEEE 830-1998 standard for writing SRS document
- Sommerville, Software Engineering, 8th edition, Addison- Wesley, 2007

3.2. Overall Description

3.2.1. Product Perspective

CMAH Web App is an innovative web app that will facilitate patients by saving their time and avoiding to travel long distance for checkup through E-Prescription.

3.2.2. Product Functions

Register: User can register into the system.

Login: User can Login the system.

Search Doctor: After login, Patient can search doctor according his need.

Check Doctor's Profile: Patient can check doctors' profile before appointment

Select Doctor: User can select his desired Doctor.

Appointment: Then appointment will be taken from selected doctor.

Send Disease image: Patient can send diseased body part picture to doctor for image prescription without visiting hospital.

Payment: If patient has taken appointment for checkup in hospital, then payment will be given in cash. In case image prescription, payment will be proceeded through credit card.

Receive Prescription: Doctor will diagnose and send online prescription in case of image prescription.

Look for Nearest Hospital or Pharmacy: Patient can find nearest hospital or pharmacy around his home.

View Disease image: Doctor will see and analyze picture sent by patient for diagnosis in image prescription.

Send Prescription: After analyzing picture diagnosing disease, doctor will send prescription to patient.

Logout:After all processes, users will logout.

3.2.3. User Classes and Characteristics

There are 3 kinds of client of this product

Patients:

Patients can use this platform for search medicine of the disease or for taking appointment from Doctor, for sending disease photo to doctor for image prescription, to see doctors' profile, to view health tips, to see medicine details, to find nearest hospital or pharmacy.

Doctors:

Doctor can view disease photo and send image prescription, E-Referrals and can give tips for health care.

Administrator:

Administrator can add update or delete, generate medicine and vaccination alert.

3.2.4. Operating Environment

Windows 7/8/10

Processor: Core2 Duo or above

RAM: At least 512MBs

For users:

This system will operate in browsers like Mozilla, Firefox, and Opera and for their different version also.

3.2.5. Design and Implementation Constraints**Tools**

- XAMP Server
- Sublime

Techniques

- Java Script
- PHP
- Bootstrap
- CSS+HTML

3.2.6. User Documentation

User must know detail of our website. User use internet to check information about disease and medicine and to take appointment or need friendly environment. We can create a simple word document for user for guide and help.

3.2.7. Assumptions and Dependencies

- Microsoft SQL Server to store the database.
- Java Script, PHP, CSS+HTML need to accomplish project.

3.3. External Interface Requirements

3.3.1. User Interfaces

The user interface of our website is simple. Currently, we design our GUI by using a html cascading style sheet and bootstrap. Because our two main users one is a patient and the second one is a doctor so we build our GUI by understanding the needs of both users.

3.3.2. Hardware Interfaces

- Processor
- RAM: 512 or above
- Hard Disk: 20 GB+
- Just the prescribed setup (fundamental necessities of a PC framework) no other.
- particular equipment is required to run the product

3.3.3. Software Interfaces

- External Machine is not required as since all configuration or computing will be done on Windows OS.
- My SQL will also be used.
- It will also include GUI developed on HTML, CSS and Java Script.

3.3.4. Communications Interfaces

User on internet will be using HTTPs



Figure 2.1- Communication Interface

3.4. System Features

Web Application

Features

- **Register:** User can register into the system.
 - **Login:** User can Login the system.
 - **Search Doctor:** After login, Patient can search doctor according his need.
 - **Check Doctor's Profile:** Patient can check doctors' profile before appointment.
 - **Select Doctor:** User can select his desired Doctor.
 - **Appointment:** Then appointment will be taken from selected doctor.
 - **Send Disease Image:** Patient can send diseased body part picture to doctor for image prescription without visiting hospital.
 - **Payment:** If patient has taken appointment for checkup in hospital, then payment will be given in cash.
- Receive Prescription:** Doctor will diagnose and send online prescription in case of image prescription.

- **View Disease Image:** Doctor will see and analyze picture sent by patient for diagnosis in image prescription.
 - **Send Prescription:** After analyzing picture diagnosing disease, doctor will send prescription to patient.
- Logout:** After all processes, users will logout.

3.4.1. System Feature 1

Functional Requirement 1

Register function

“User can register into the System”

Identifiers	FR-001
Title	Allow Register access online
Requirement	User Name, Password ,Email, Phone number
Rational	Register to system and provide security to personal information.
Restrictions and Risks	Correct data should be entered otherwise one can't register.
Dependency	Connection with server
Priority	Safety and Timing

Table 2a- Function Requirement Register

Use Case 1

Register:
Actor
<ul style="list-style-type: none">• Unregistered-User
Precondition
<ul style="list-style-type: none">• User must open the website• User must open the registration page.
Basic Flow
<ul style="list-style-type: none">• User should provide all required information and get registered.
Post Condition
<ul style="list-style-type: none">• User Must Register Successfully.

Table 2a- Use case Register

Diagram 1

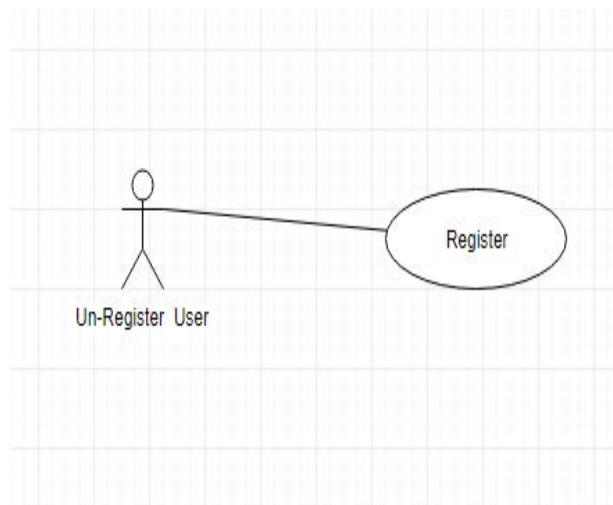

Figure 2a-Use Case Register

System feature 2

Functional requirement 2

Login Function

“User can login into the system”

Identifiers	FR-002
Title	Allows login access online
Requirement	User Name, Password
Rational	Login to system and provide security to personal information.
Restrictions and Risks	Correct data should be entered otherwise one can't Login.
Dependency	Connection with server

Priority	Safety and Timing
----------	-------------------

Table 2b-Function Requirement Login

Use Case 2

Login:
Actor
<ul style="list-style-type: none"> Registered-User
Precondition
<ul style="list-style-type: none"> User must have open the website. User must have account.
Basic Flow
<ul style="list-style-type: none"> User enters user-name, password and gets login .
Alternate flow
<ul style="list-style-type: none"> User can use this web application as unregister user.
Post Condition
<ul style="list-style-type: none"> User Mustbe Successfully login.

Table 2b-Use Case 2 Login

DIAGRAM 2



Figure 2b-Use Case Diagram Login

System feature 3

Functional requirement 3

LogoutFunction

“After all processes are completed user can logout”

Identifiers	FR-003
Title	Allows logout access online
Requirement	None
Rational	Logout to system and provide security to personal information.
Restrictions and Risks	User must login.
Dependency	Connection with server
Priority	Safety and Timing

Table 2c-Function Requirement Logout

Use Case 3

Logout:
Actor
<ul style="list-style-type: none">Registered-User
Precondition
<ul style="list-style-type: none">User must be successfully login.
Basic Flow
<ul style="list-style-type: none">User want to logout.
Post Condition
<ul style="list-style-type: none">User must logout.

Table 2c-Use case 3 Logout

DIAGRAM 3

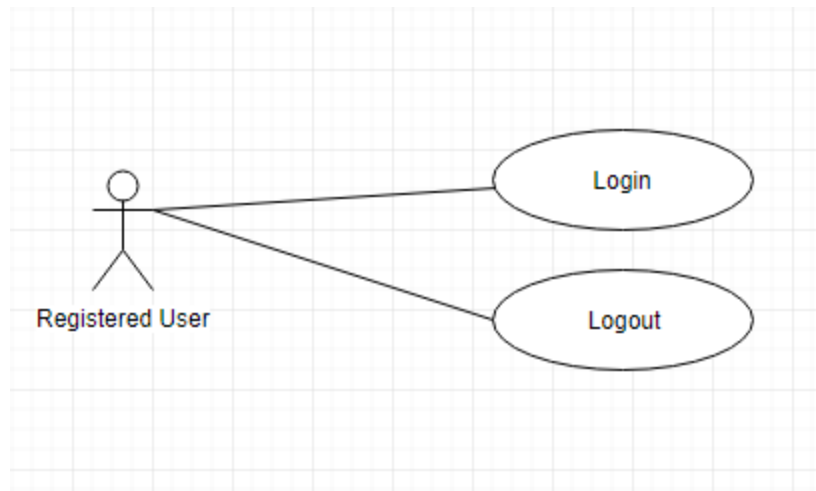

Figure 2c-Use case 3 Logout

System feature 4

Functional requirement 4

Search and Select Doctor Function

“User can search and select doctor for appointment”

Identifiers	FR-004
Title	Search and Select doctor
Requirement	None
Rational	Patient must search and select doctor.
Restrictions and Risks	None
Dependency	Valid information.
Priority	None

Table 2d-Function Requirement Search and Select Doctor

Use Case 4

Search and Select doctor:

Actor
<ul style="list-style-type: none"> Registered-User
Precondition
<ul style="list-style-type: none"> User must be successfully login.
Basic Flow
<ul style="list-style-type: none"> User want to search and select doctor.
Post Condition
<ul style="list-style-type: none"> None

Table 2d-Use Case Search and Select Doctor

DIAGRAM 4

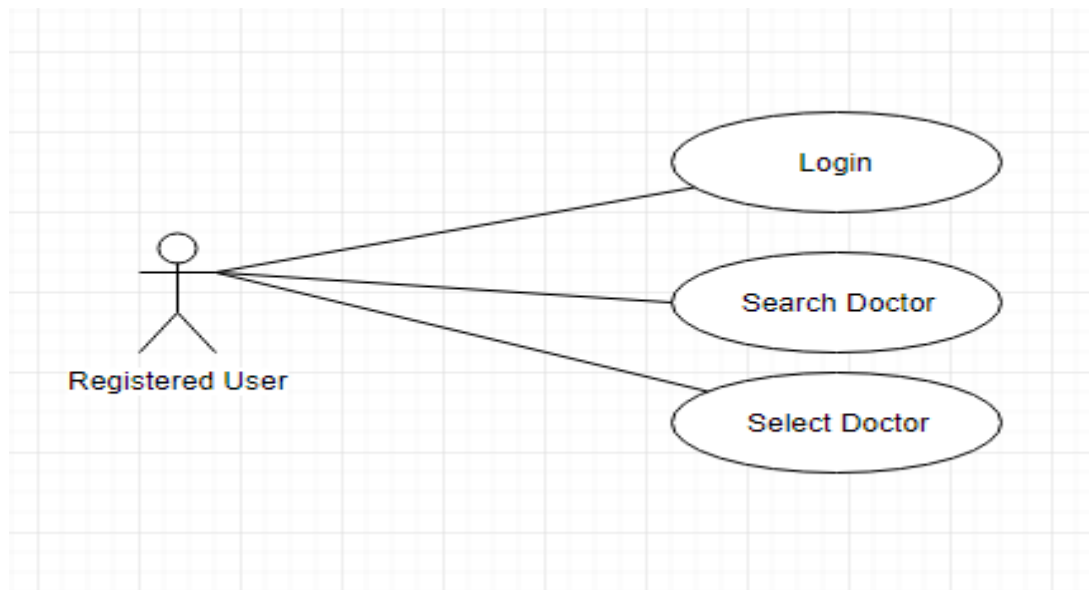

Figure 2d-Use Case Diagram Search and Select Doctor

System feature 5

Functional requirement 5

Appointment Function

“User can get the appointment”

Identifiers	FR-005
Title	Appointment
Requirement	Username,doctorname,time,date.
Rational	Patient want to get appointment.
Restrictions and Risks	Information must be correct.
Dependency	Valid information.
Priority	Desired doctor

Table 2e-Function Requirement get appointment

Use Case 5

Appointment:
Actor
<ul style="list-style-type: none"> Registered-User
Precondition
<ul style="list-style-type: none"> Information must be correctly entered.
Basic Flow
<ul style="list-style-type: none"> User want to get appointment.
Post Condition
<ul style="list-style-type: none"> None

Table 2e-Use Case get appointment

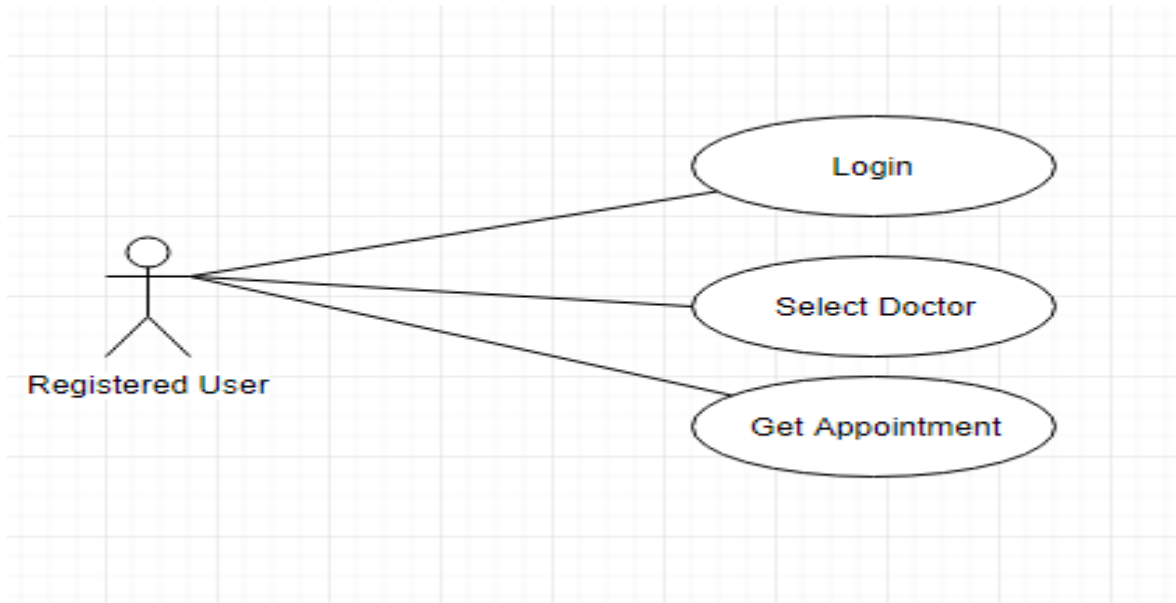
DIAGRAM 5**Figure 2e-Use Case Diagram View Detail****System feature 6****Functional requirement 6****Send Disease Image Function**

“User will send disease image to doctor”

Identifiers	FR-006
Title	Access to Send Disease image
Requirement	Patient Must have account Must be logged in successfully
Rational	Send Diseased part image to doctor for image prescription
Restrictions and Risks	None
Dependency	Connection with server
Priority	Safety and Timing

Table 2F-Funcation Requirement send disease image

Use Case 6

Send Disease Image:
Actor
<ul style="list-style-type: none"> Registered-User
Precondition
<ul style="list-style-type: none"> Must be logged in Correctly
Basic Flow
<ul style="list-style-type: none"> User wants to send image for Image Prescription
Post Condition
<ul style="list-style-type: none"> Image will be sent to doctor for image prescription

Table 2F-Use Case send disease image

DIAGRAM 6

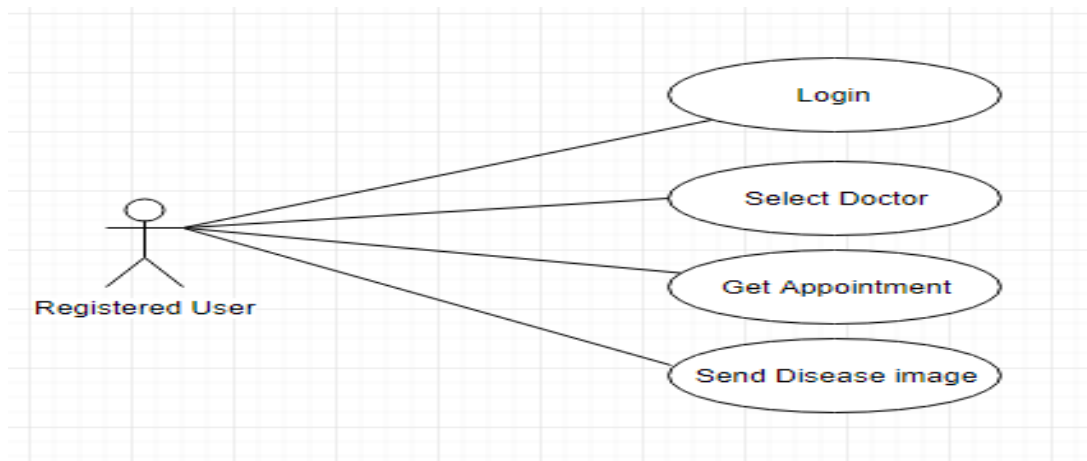

Figure 2F-Use Case Diagram send disease image

System feature 7

Functional requirement 7 Receive Image Prescription Function

“Patient will receive image prescription sent by doctor”

Identifiers	FR-008
Title	Allow patient to receive and view image prescription sent by doctor.
Requirement	Patient must have sent disease image to doctor.
Rational	User receives image prescription and view it.
Restrictions and Risks	None
Dependency	None
Priority	None

Table 2h-Function Requirement Receive Image Prescription

Use Case 7

Receive Image Prescription
Actor
<ul style="list-style-type: none"> Registered-User
Precondition
<ul style="list-style-type: none"> Must have sent disease image to doctor
Basic Flow
<ul style="list-style-type: none"> Patient will receive image prescription from Doctor
Post Condition
<ul style="list-style-type: none"> User will see image prescription

Table 2h-Use Case Receive Image Prescription

DIAGRAM 7

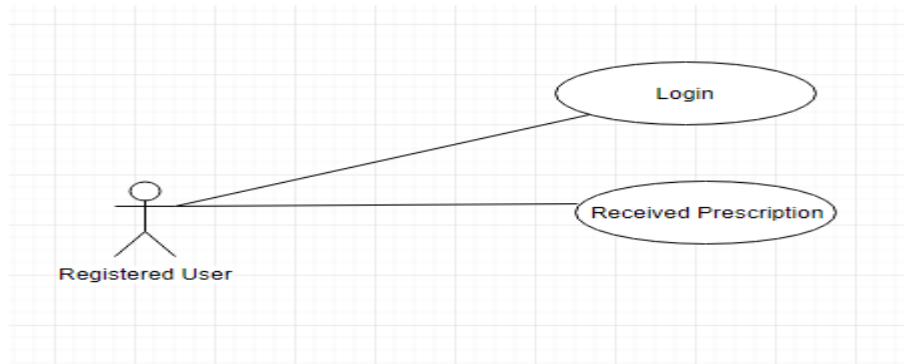

Figure 2h-Use Case Diagram Receive Image Prescription

System feature 8

Functional requirement 8 View Disease Image Function

“Doctor will receive and view disease image sent by Patient”

Identifiers	FR-009
Title	Allow doctor to see disease image
Requirement	Patient must have sent disease image
Rational	View disease image to diagnose
Restrictions and Risks	None
Dependency	Connection with server
Priority	None

Table 2i-Function Requirement View diseases image

Use Case 8

View disease image

Actor
<ul style="list-style-type: none">Registered-User
Precondition
<ul style="list-style-type: none">Patient must have sent disease image.
Basic Flow
<ul style="list-style-type: none">Doctor wants to view disease image.

Table 2i-Use Case View disease image

DIAGRAM 8

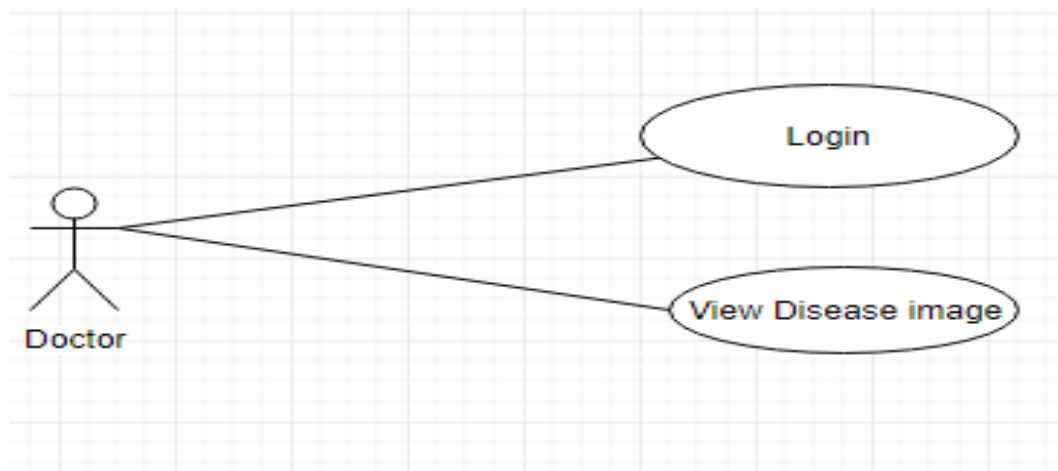

Figure 2i-Use Case Diagram View disease image

System feature 9

Functional requirement 9

Send Prescription Function

“Doctor will send image prescription to Patient”

Identifiers	FR-10
Title	Allow doctor to send Prescription to patient
Requirement	Must have viewed disease image
Rational	Send Image prescription to patient
Restrictions and Risks	None
Dependency	Connection to server
Priority	None

Table 2j-Function Requirement send prescription

Use Case 9

Send prescription
Actor
<ul style="list-style-type: none"> Registered-User
Precondition
<ul style="list-style-type: none"> Patient must have sent disease image to doctor
Basic Flow
<ul style="list-style-type: none"> Doctor wants to send prescription to patient
Post Condition
<ul style="list-style-type: none"> Patient will receive prescription

Table 2j-Use Case send prescription

DIAGRAM 9

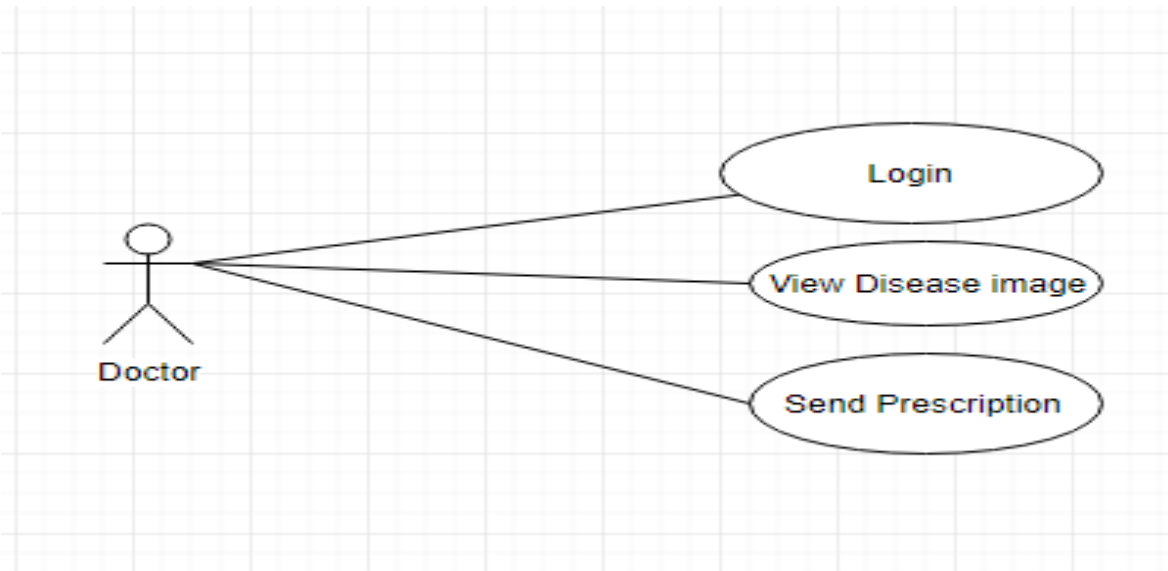

Figure 2j-Use Case Diagram send prescription

3.5. Other Nonfunctional Requirements

3.5.1. Performance Requirements

With a specific end goal to keep up a worthy speed at most extreme number of transfers permitted from a specific user will be any number of user and can get to the framework whenever. Likewise associations with the servers will be founded on the criteria of properties of the client, and server will work 24X 7 times.

3.5.2. Safety Requirements

All exchanges, logged data, refreshes, user exercises are reinforcement.

3.5.3. Security Requirements

Any adjustment (insert, update and delete) for the Database might be synchronized and done just by the admin.

3.5.4. Software Quality Attributes

Reliability

The framework can be utilized by different users simultaneously. Any user can get to the framework with utilizing even a low execution PC.

Availability

The framework is accessible amid 24 hours of the day.

Maintainability

The framework should give the ability to go down the Data.

Portability

User can sign in to the framework whenever.

Robustness

The framework won't be separated effortlessly.

3.5.5. Business Rules

There are mostly two kinds of clients utilizing the framework, for example,

- **User**
- **Administrator**

Administrator has the full authorization of controlling the framework.

User has authorization to appointment request, send disease photo for image prescription, view doctor's profile, view disease details.

3.6. Other Requirements

Technical Feasibility

CMAH require following advances:

Server: A server will be required which will have all information of customer. It check client name and passwords of the considerable number of clients, the areas went by the clients, an occasion created by client e.g. data about some strike in the way.

Schedule Feasibility:

We isolate the undertaking into various modules and prerequisite modules will be constructed and afterward would be coordinated to make an appropriate working application.

Motivational Feasibility:

The thought is given by an instructor and we are engaged to defeat the thought. As this platform appear to be extremely useful for individuals.

Legal & Ethical Feasibility:

This platform would be accessible for all clients and will meet legitimate and moral principles. As the client who will produce occasions would be a valid client with client data accessible so it is imagined that it would be a decent affair to utilize this application.

Chapter 3

Use Case Analysis

Chapter 3:

System Analysis

CMAH is a web application and utilizations server. The web program fills in as a UI for the Framework. The web program speaks with the server utilizing HTTP as transport convention. Web program sends solicitations to the server and the server react to web in HTML organize, Web app program, at that point show the data to the client. WIFI or Ethernet is utilized and it needs a legitimate system. My SQL Database dwells on the server when client information is stored and handled.

3.1. Use Case Model



Figure 3.1- Use Case

Chapter 4

System Design

Chapter 4: System Design

This chapter contains the key-diagrams and models to visually represent the system. The system design has been briefed below: The application will follow client server architecture. This is an online application and the server will manage the delivery of most of the resources.

4.1. Architecture Diagram

[=

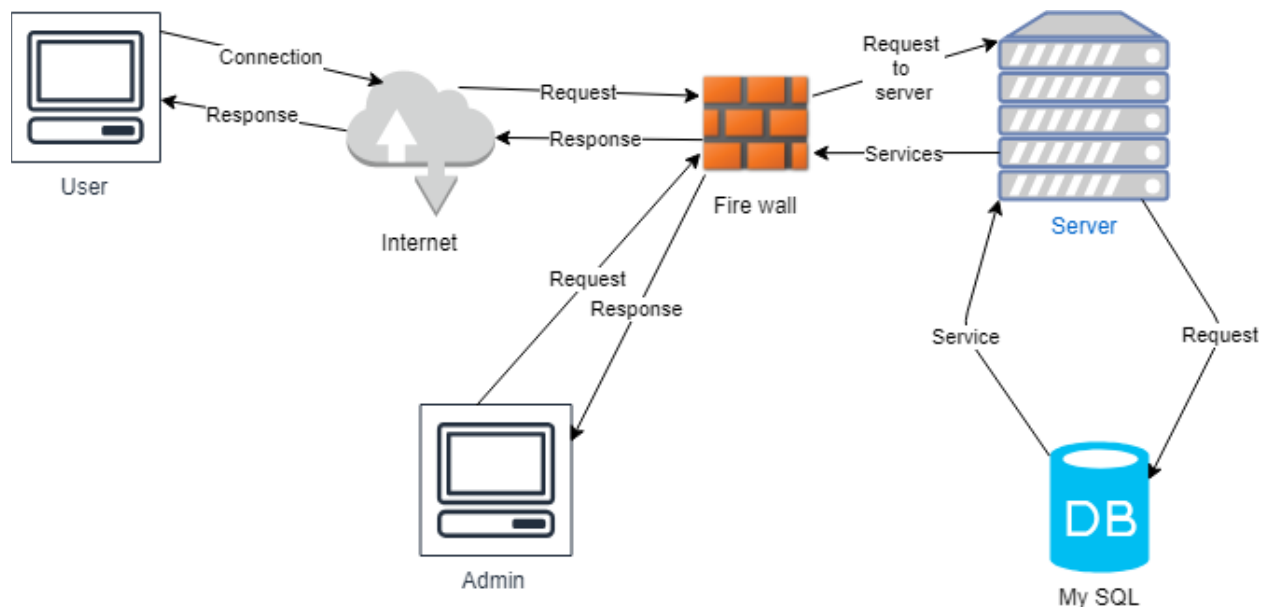

Figure 4.1- Architecture diagram

4.2. Domain Model

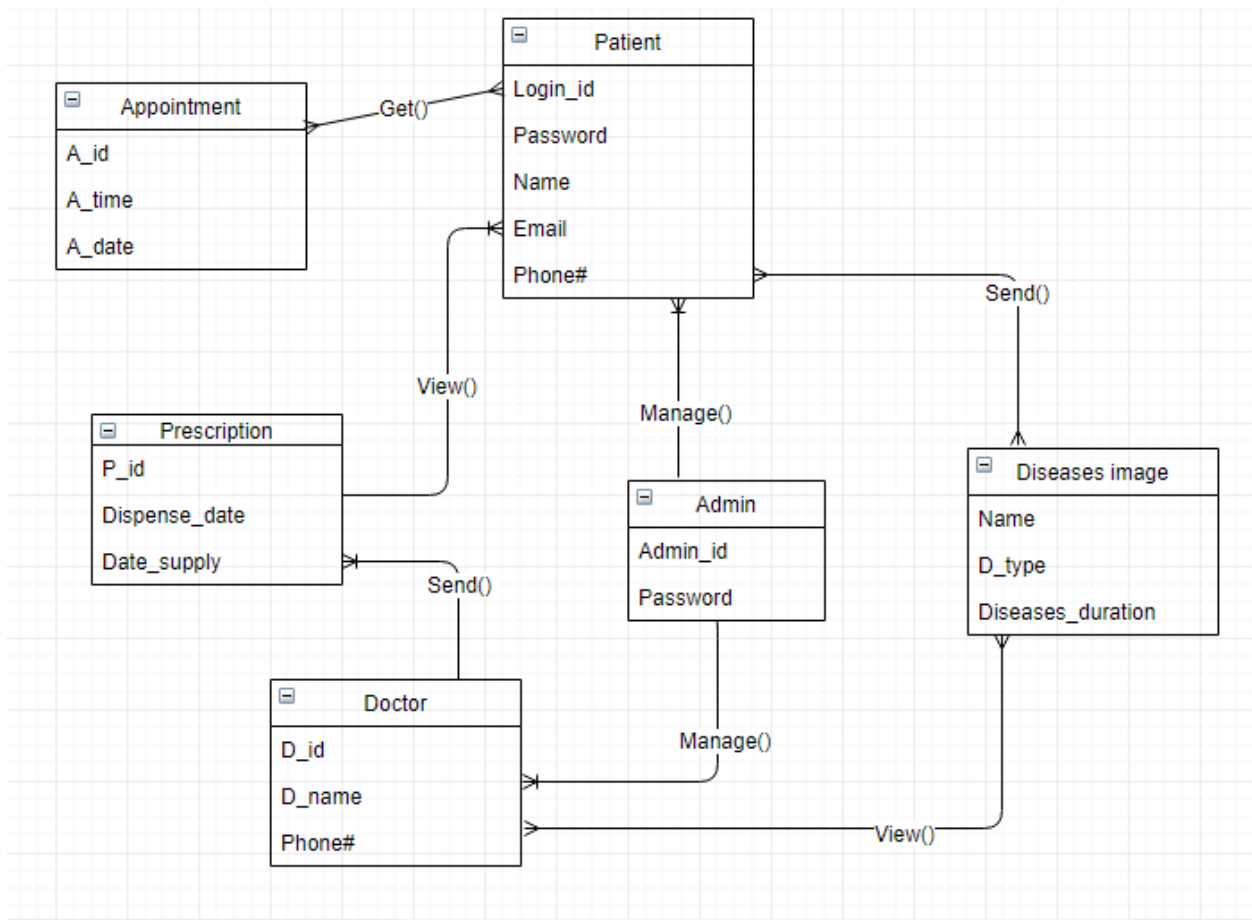

Figure 4.2- Domain model

4.3. Entity Relationship Diagram with data dictionary

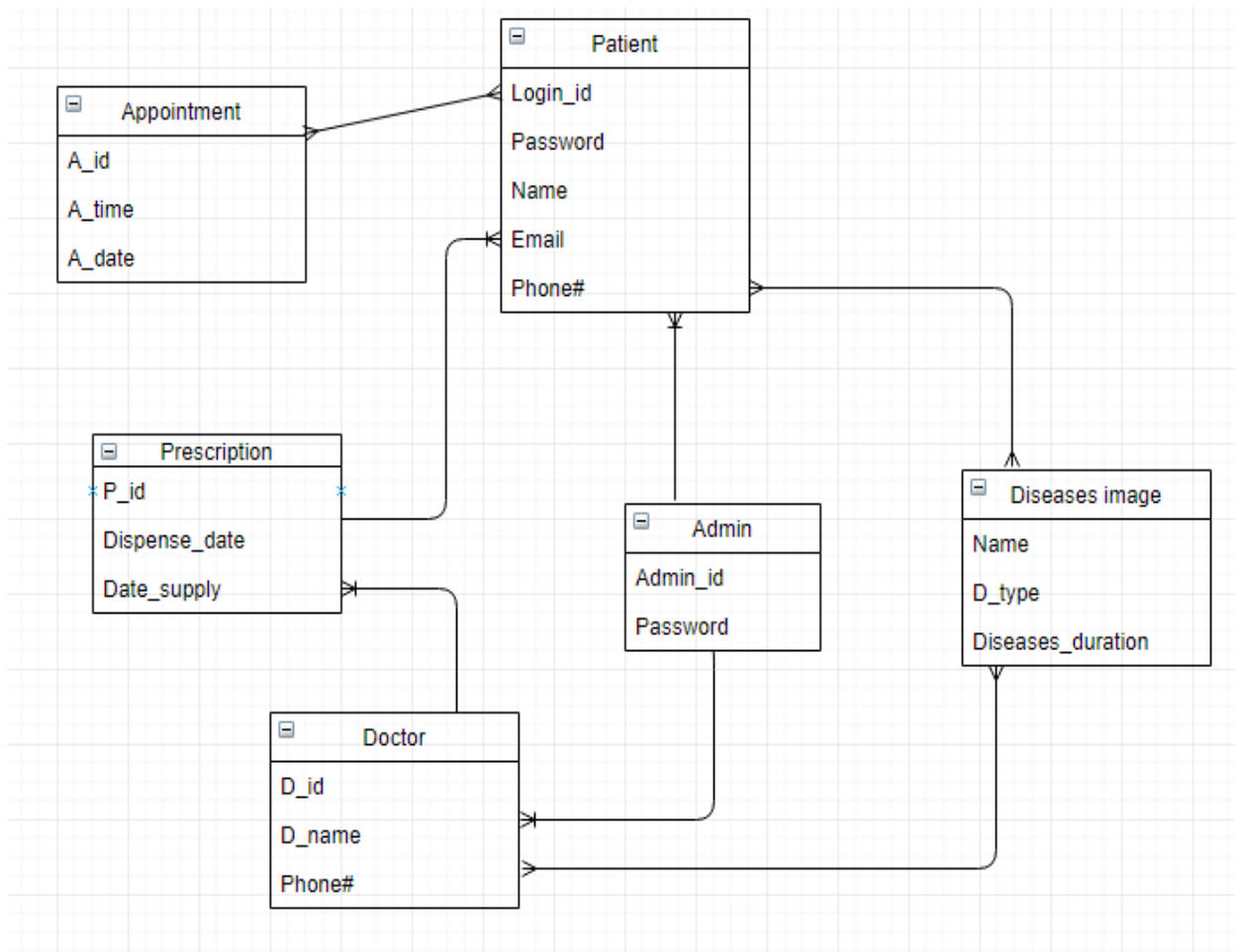

Figure 4.3- ERD diagram

4.4. Class Diagram

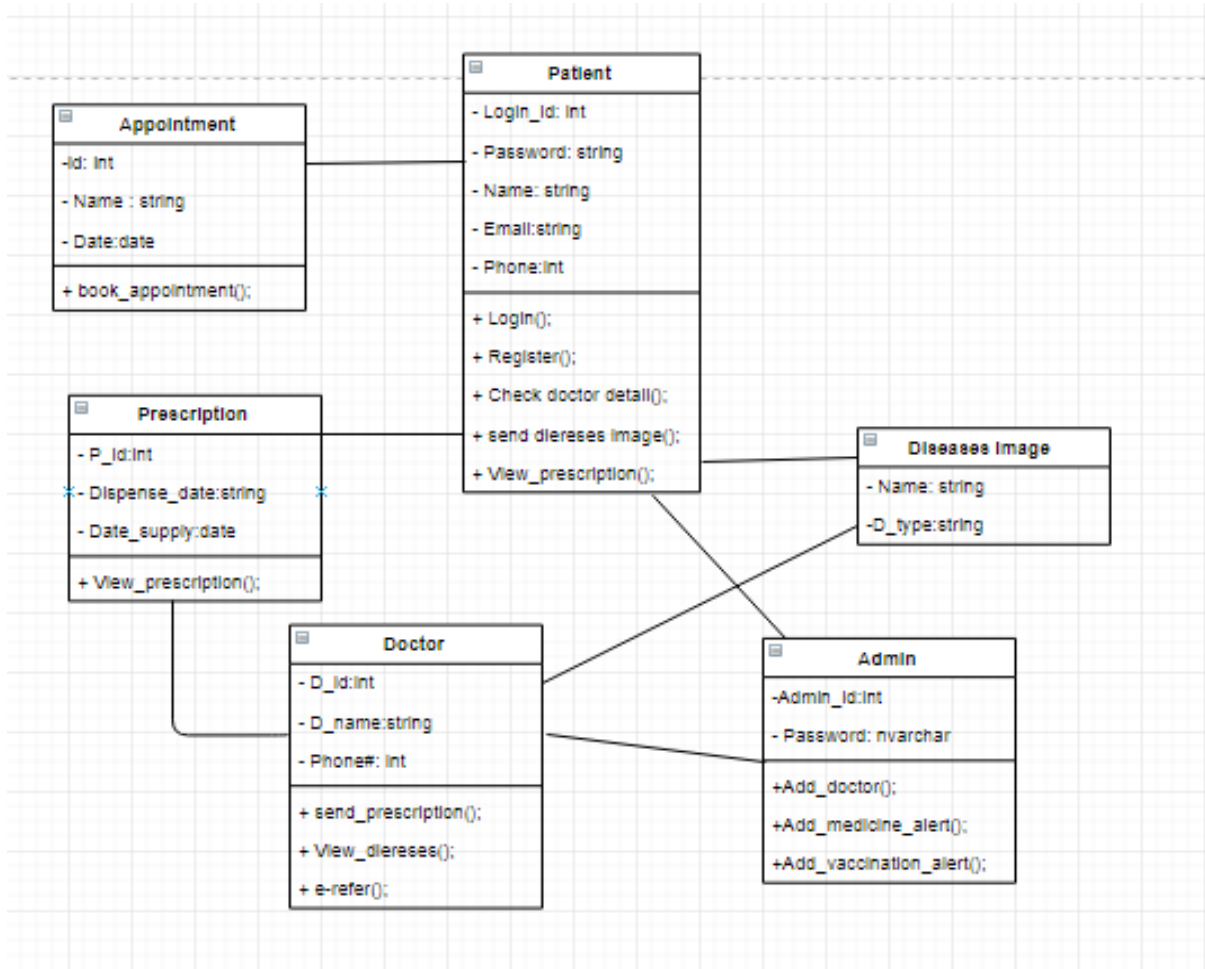
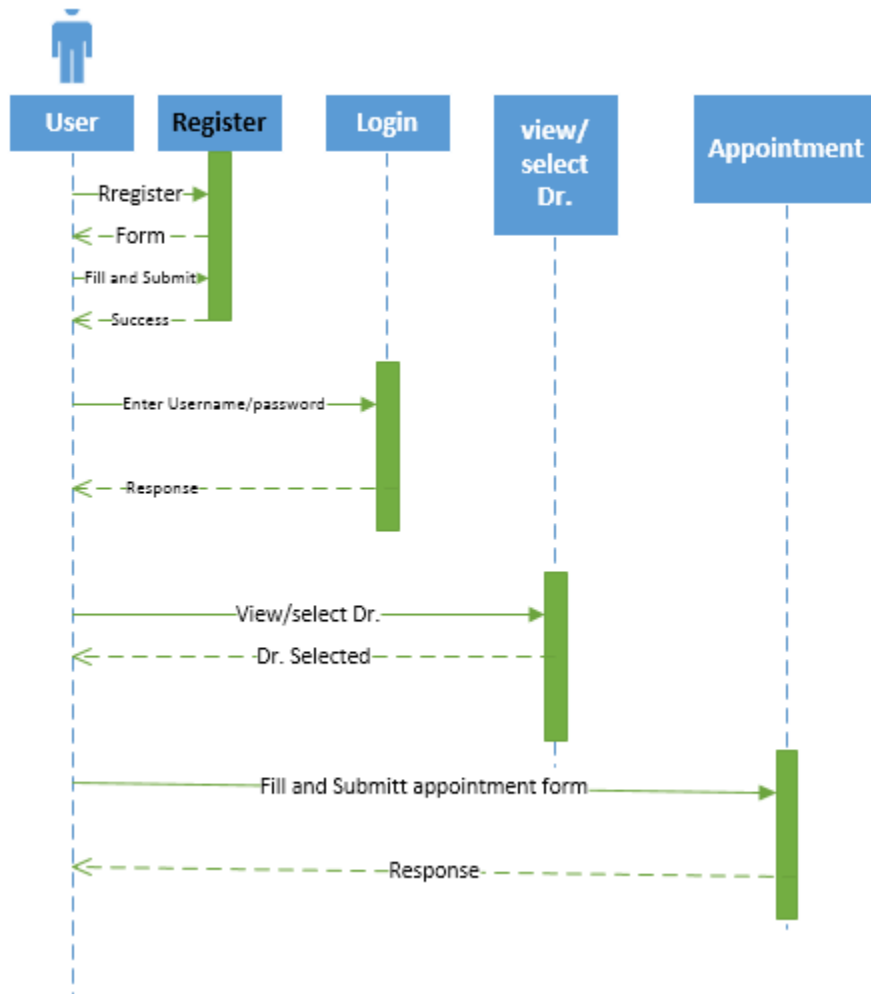

Figure 4.4- Class diagram

4.5. Sequence / Collaboration Diagram



4.6. Operation contracts

4.6.1 Operation Contract #1

Name: Register.

Responsibilities: To register the new user.

Cross References: Register.

Exceptions: None.

Preconditions: Register interface must be opened and user must enter valid information.

Post conditions: Welcome screen showed to the user.

4.6.2 Operation Contract #2

Name: Login

Responsibilities: A user is logged in

Cross References: Login

Exceptions: Invalid Authentication

Preconditions: User must have account

Post conditions: Logged in successfully

4.6.3 Operation Contract #3

Name: Logout

Responsibilities: User is logged out.

Cross References: Logout.

Exceptions: None.

Preconditions: User must have logged in.

Post conditions: Logged out successfully.

4.6.4 Operation Contract #4

Name: Search and Select Doctor.

Responsibilities: Patient will search and select doctor for image prescription.

Cross References: Search and select doctor.

Exceptions: None.

Preconditions: Must be logged in.

Post conditions: Doctor will be chosen for appointment.

4.6.5 Operation Contract #5

Name: View doctor list and profile.

Responsibilities: User will see doctors' list and profiles.

Cross References: Doctor's List and Doctor's Profile.

Exceptions: None.

Preconditions: Must Logged in

Post conditions: Doctors' list and Profiles will be displayed.

4.6.6 Operation Contract #6

Name: Send disease image.

Responsibilities: Patient will send disease image to doctor for image prescription.

Cross References: Send Disease image.

Exceptions: None.

Preconditions: Patient must be logged in.

Post conditions: Disease image will be delivered to doctor.

4.6.7 Operation Contract #7

Name: Detail of Medicine.

Responsibilities: To see detail of medicines.

Cross References: Medicine Details.

Exceptions: None.

Preconditions: None.

Post conditions: Medicine Details will be displayed

4.6.8 Operation Contract #8

Name: View Disease image

Responsibilities: Doctor will see disease image sent by patient.

Cross References: View disease image.

Exceptions: None.

Preconditions: Disease image must be sent by patient.

Post conditions: Disease image will be displayed to doctor.

4.6.9 Operation Contract #9

Name: Send prescription.

Responsibilities: To send prescription to patient.

Cross References: Send Prescription.

Exceptions: None.

Preconditions: Disease image must be sent to doctor by patient.

Post conditions: Prescription will be delivered to patient.

4.7. Activity Diagram

USER side:

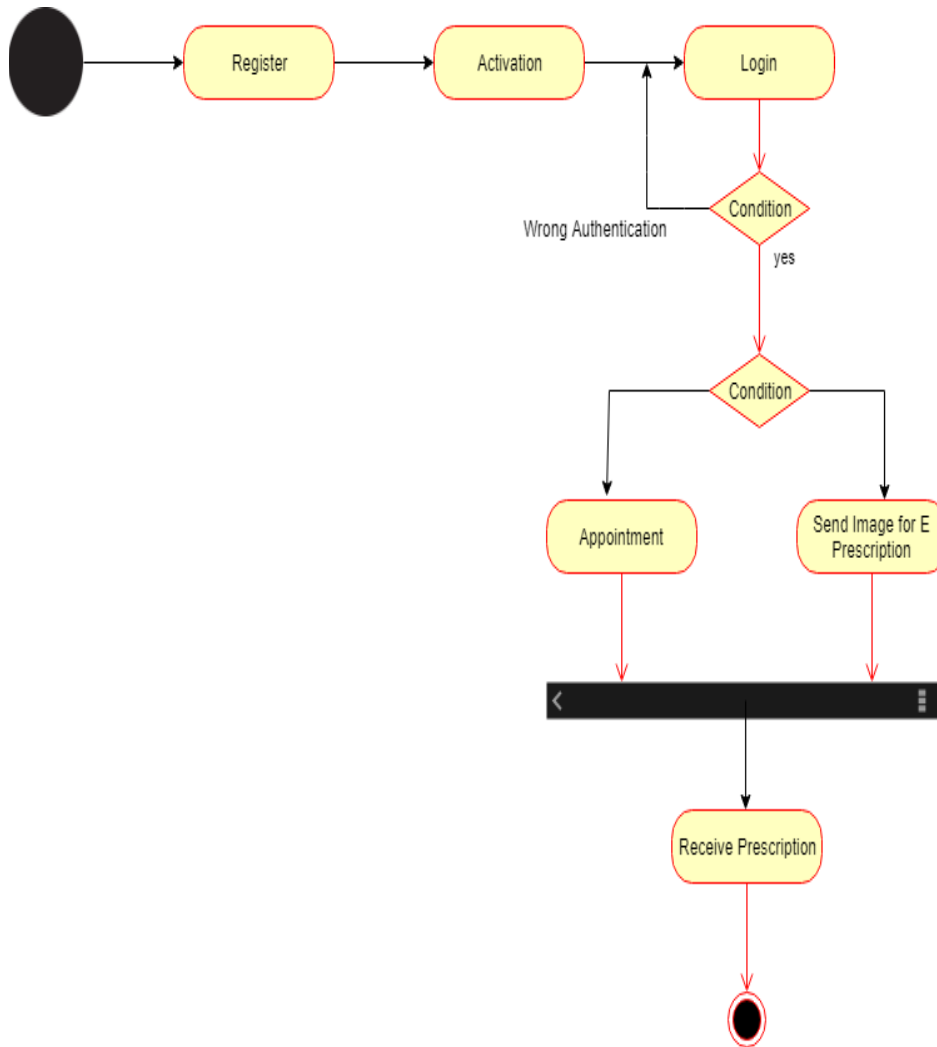

Figure 4.6- Activity diagram

Doctor side

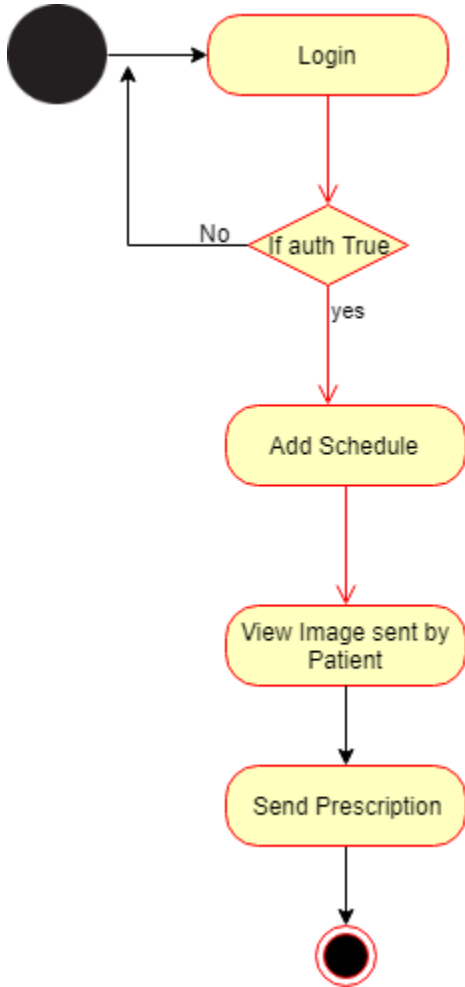

Figure 4.7- Activity diagram

Admin side

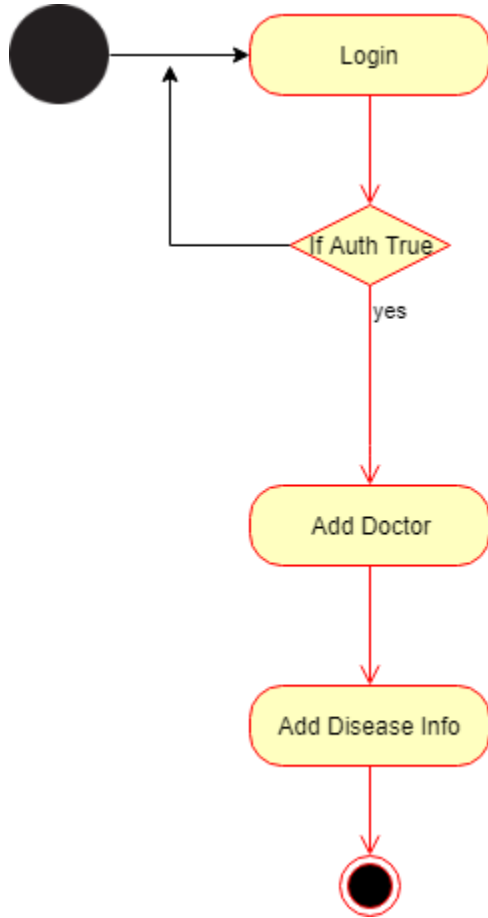

Figure 4.8- Activity diagram

4.8. State Transition Diagram

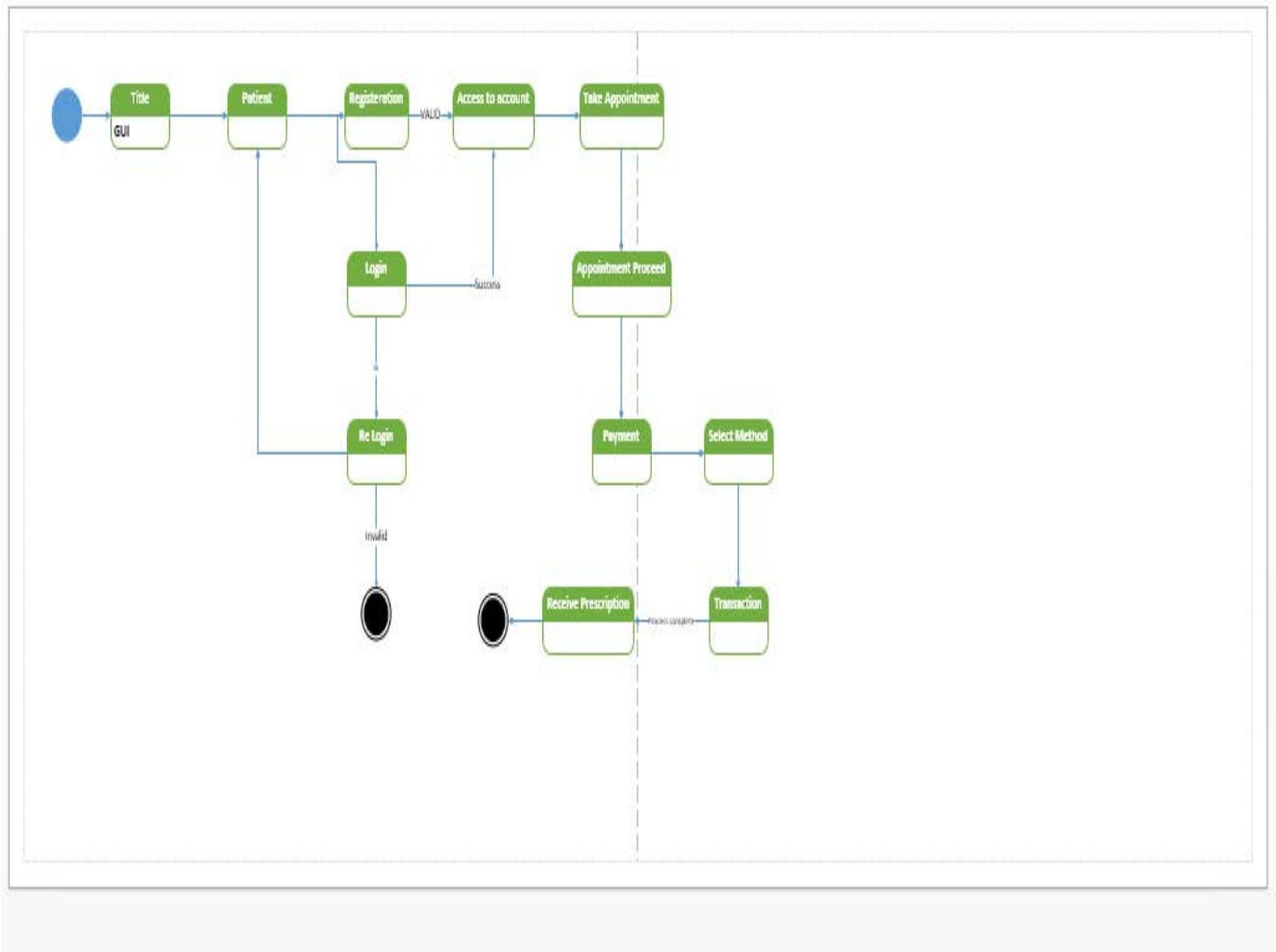

Figure 4.9- State diagram

4.9. Component Diagram

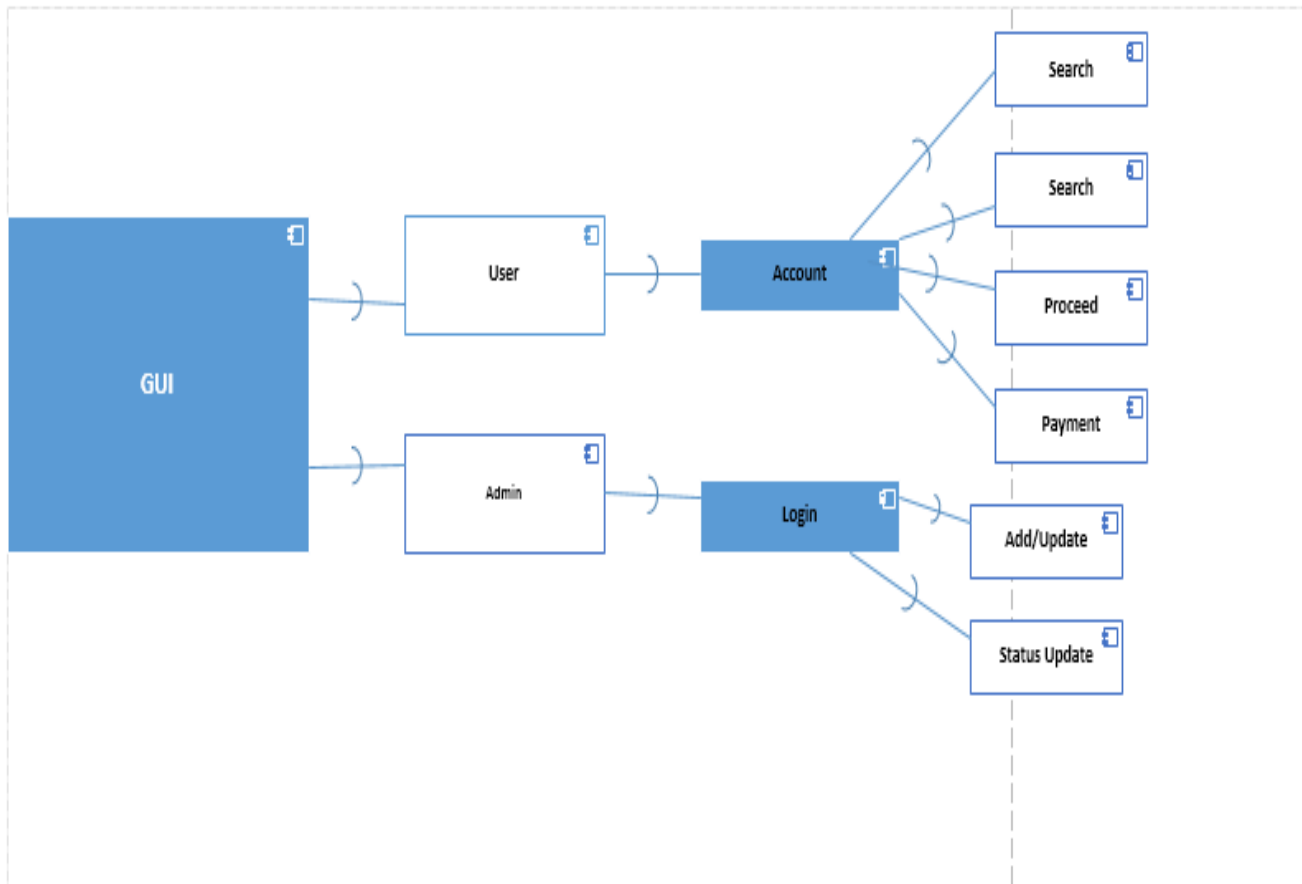

Figure 4.10- Component diagram

4.10. Deployment Diagram

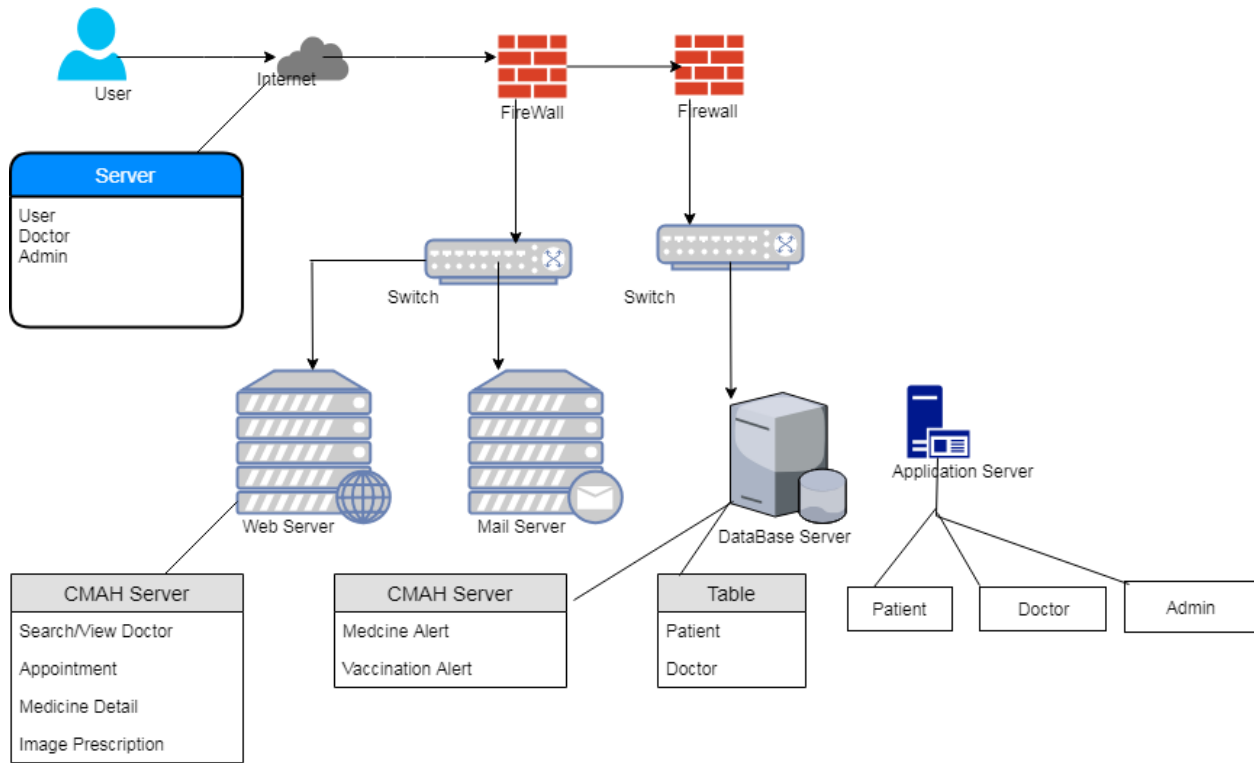

Figure 4.11- Deployment diagram

4.11. Data Flow diagram

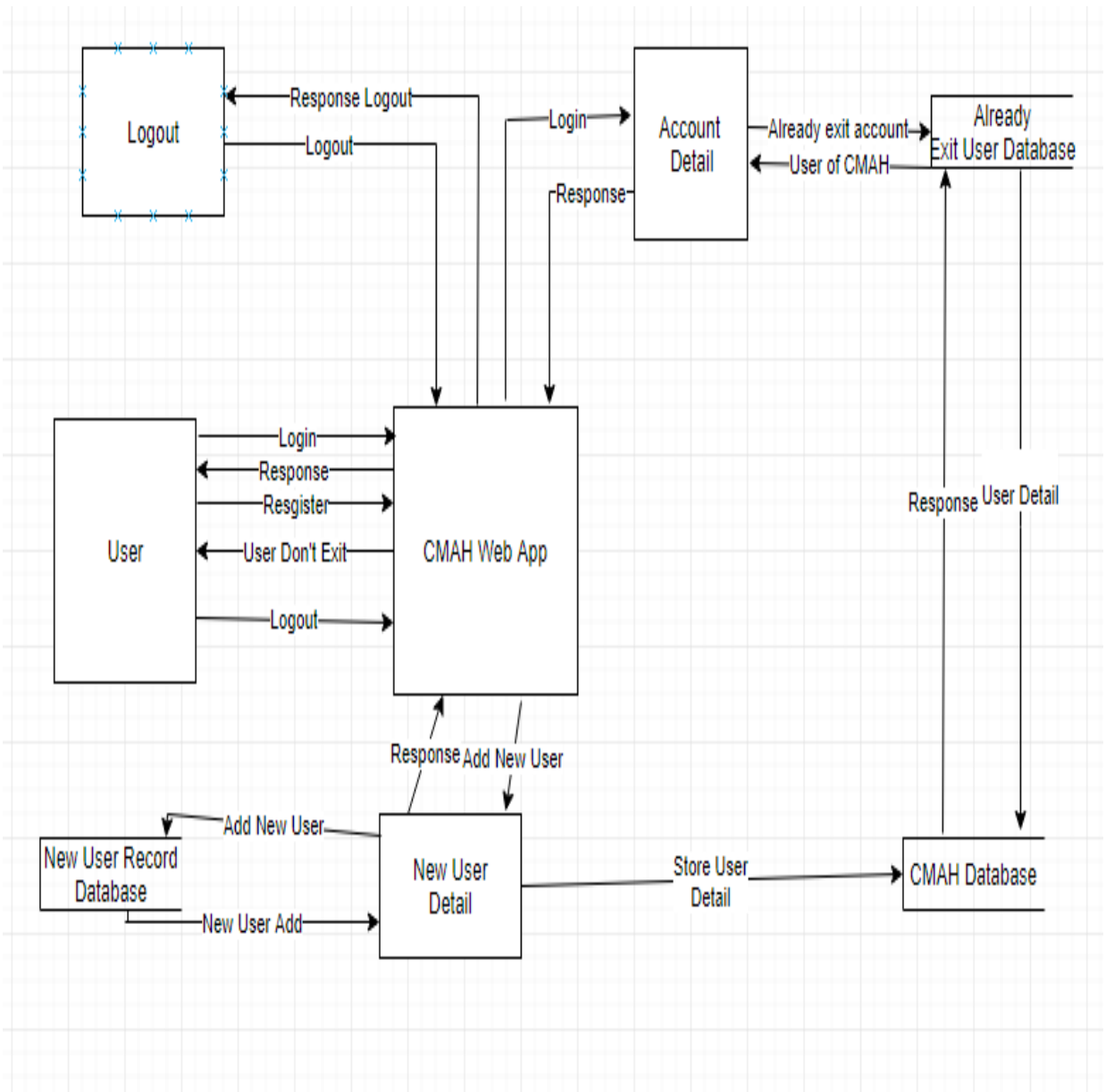

Figure 4.12- DFD of user side

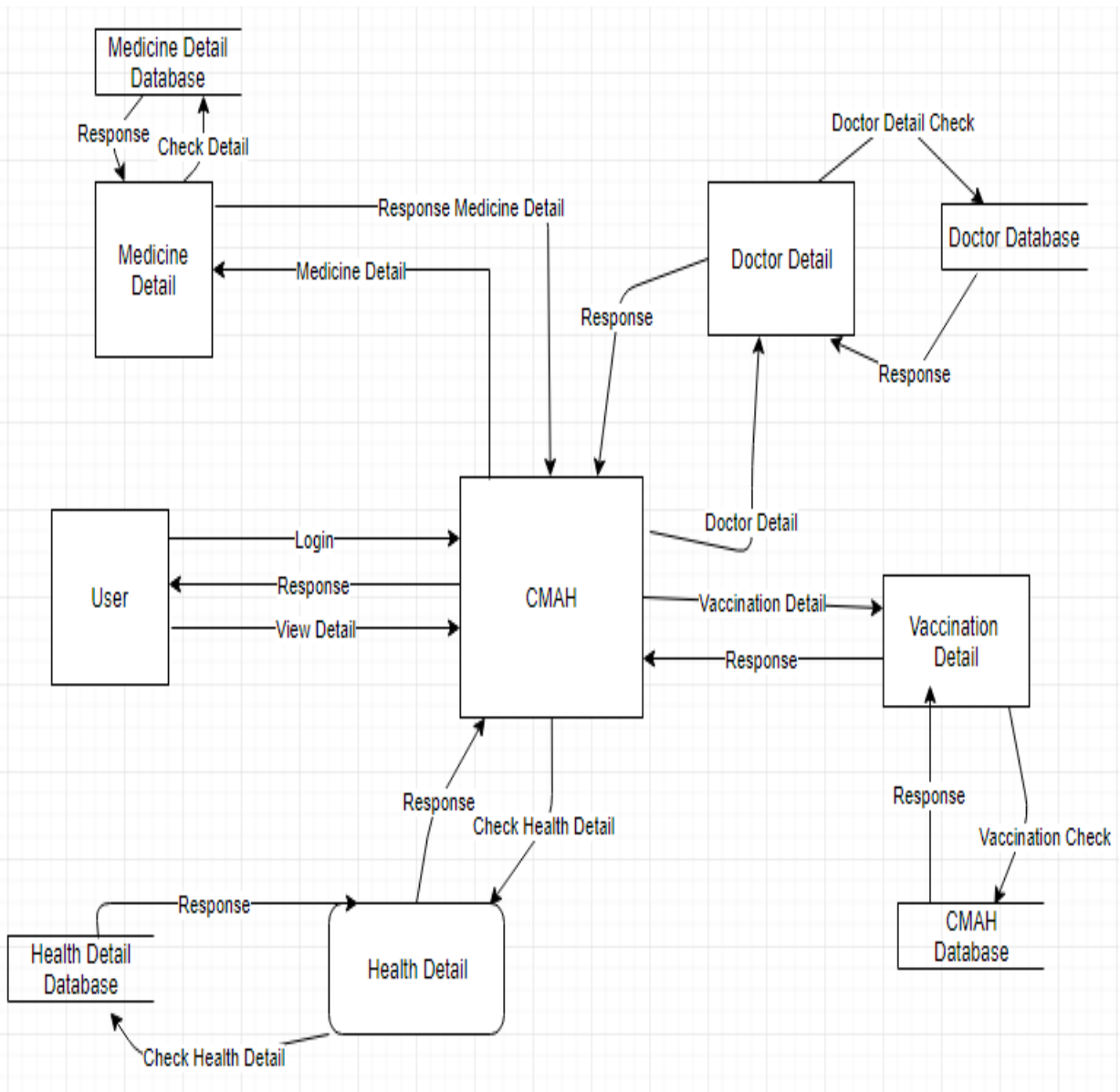

Figure 4.13- DFD User Side

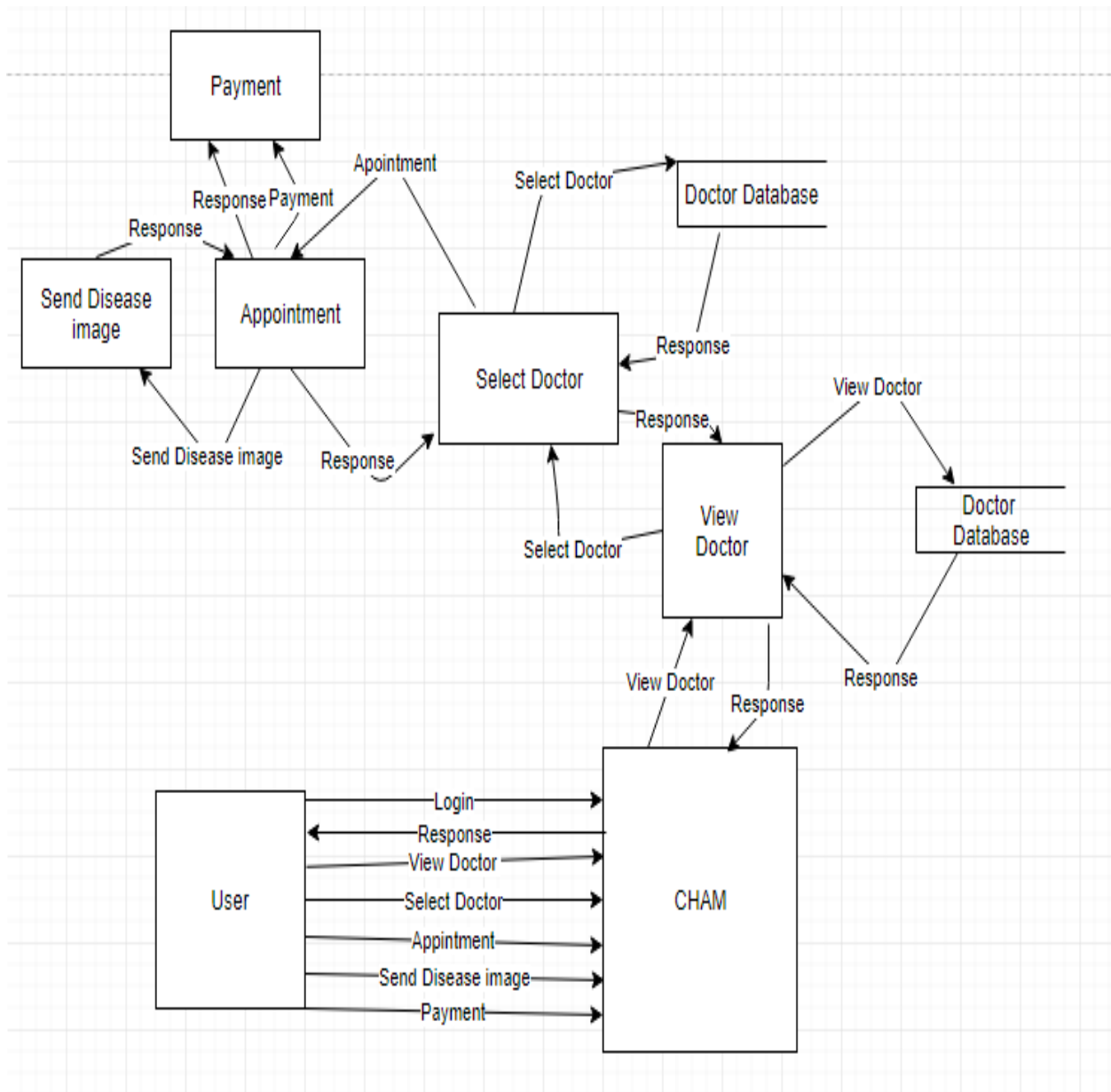

Figure 4.14- DFD User Side

Chapter 5

Implementation

Chapter 5: Implementation

This is a task with the goal to build up an essential site where a user is given a platform where user can get information about medicine and disease and also can get appointment, from Doctor add image prescription. This report will talk about every one of the fundamental advances to make and actualize a web based application.

5.1. Important Flow Control/Pseudo codes

Admin Panel:

- Login
- Checks activity log
- Add doctor
- Add medicine info
- Decision Making, Add and remove doctor
- Edit Doctor profile

Doctor Panel:

- Login
- View diseases image
- send prescription

Patient Panel:

- Login
- Get appointment
- Send diseases image
- Check Doctor's list
- Receive prescription
- Check doctor profile

5.2. Components, Libraries, Web Services and stubs

Components, Libraries:

- Bootstrap 4, PHP, JavaScript, HTML, CSS

5.3. Deployment Environment

Browser:

- Chrome
- Firefox

Operating system:

- Window 7,8 and so on.

5.4. Tools and Techniques

- Sublime Text 3
- Adobe Photoshop

Languages:

- PHP, JAVA Script, HTML 5, CSS 3

5.5. Best Practices / Coding Standards

- Files MUST use only <? PHP and <? = tags
- No coding repetition
- Method names MUST be declare in Camel Case.
- Must use date time function for PHP
- Function and classes are always commented showing expected input and output.

5.6. Version Control

GIT

GIT is a version-control system for tracking changes in computer files and coordinating work on those files among multiple people. It is primarily use for source-code management in software development, but it will be used to keep track of changes in any set of files.

Chapter 6

Testing and Evaluation

Chapter 6: Testing and Evaluation

TEST CASE 1

Register

Test suite ID	S001
Test Case ID	C001
Actor	Unregister user
Test case summary	To verify that Register button saves new user.
Related requirement	New user should be able to sign up.
Prerequisites	None
Test Procedure	<ol style="list-style-type: none"> 1. Open the website, press portal Button and press Registration Button. 2. Fill Form: User-name, Password, Email, phone#. 3. Click Register Button.
Test data	<p>For Username Field: Jackson, Maize, Akon.</p> <p>For Password field: 12345, 2345, shields.</p> <p>Email: abc@gamil.com, xyz@gmail.com , wer@gmail.com</p> <p>Phone Number: 03314693456,03349229234,03149837434.</p>
Expected Result	<ul style="list-style-type: none"> • The form will not be post and User will be notify "Please match the format request as the password requirement is not meet." • The form will not be post and User will be notify "Please match the format request as the password Confirmation is not

	<p>Correct.”</p> <ul style="list-style-type: none"> When User enters a Password less then (5 digits password) then a message must show “Your Password is Weak Please Enter the Strong Password to secure your account”
Actual Result	Test Successful.
Status	Pass
Created By	Ihtasham Akram
Date of Creation	24/12/18
Executed by	Ihtasham Akram
Date of execution	24/12/18

TEST CASE 2

Login:

Test suite ID	S002
Test Case ID	C002
Actor	Register User
Test Case Summery	To verify that login button functionscorrectly.
Related Requirement	None.
Prerequisites	<ul style="list-style-type: none"> User must be registered.
Test Procedure	<ul style="list-style-type: none"> Open website and press portal Button. Enter Email and password

	<ul style="list-style-type: none"> Click on the login button
Test Data	Login detail Jackson , Maize , Akon.
Expected Result	<ul style="list-style-type: none"> If the username and password are valid then the home page should be opened. When User enters in invalid Email then message show “Your Email is invalid Please Enter the correct Email, Retry option”. When User enters a wrong Password then message show “Your Password is invalid Please Enter the correct Password, Retry option”.
Actual Result	Login successful
Status	Test Successful.
Created By	Ihtasham Akram
Date of Creation	24/12/18
Executed by	Ihtasham Akram
Date of execution	24/12/18

TEST CASE 3

Search and view doctor

Test suite ID	S003
Test Case ID	C003
Actor	Register user
Test Case Summery	To verify Select doctor button is functioning correctly.
Related Requirement	User can search the doctor and view doctor detail.
Prerequisites	Use must be login.

Test Procedure	<ul style="list-style-type: none"> • Login in • User can enter a required information.
Test Data	User can view detail of the doctor
Expected Result	User can select Item
Actual Result	select doctor and get appointment
Status	Test Successful.
Created By	Ihtasham Akram
Date of Creation	24/12/18
Executed by	Ihtasham Akram
Date of execution	24/12/18

TEST CASE 4

Select Doctor:

Test suite ID	S004
Test Case ID	C004
Actor	Register user
Test Case Summary	To verify Select item button is functioning correctly.
Related Requirement	User can select doctor and get appointment
Prerequisites	User must be login.
Test Procedure	Login in Select doctor
Test Data	Available doctor
Expected	User can select Item

Result	
Actual Result	select doctor and get appointment
Status	Test Successful.
Created By	Ihtasham Akram
Date of Creation	24/12/18
Executed by	Ihtasham Akram
Date of execution	24/12/18

TEST CASE 5

Send Disease image:

Test suite ID	S005
Test Case ID	C005
Actor	Register user
Test Case Summery	To send disease for image prescription.
Related Requirement	User can search the doctor and view doctor detail.
Prerequisites	User must be login.
Test Procedure	<ul style="list-style-type: none"> • Login in • User can enter a required information.
Test Data	User can view detail of the doctor
Expected Result	User can select Item
Actual Result	Select doctor and get appointment
Status	Test Successful.
Created By	Ihtasham Akram

Date of Creation	24/12/18
Executed by	Ihtasham Akram
Date of execution	24/12/18

TEST CASE 6

Send Prescription:

Test suite ID	S006
Test Case ID	C006
Actor	Register user
Test Case Summery	To Send the prescription to the patient.
Related Requirement	User can enter required information for view prescription.
Prerequisites	User must be login.
Test Procedure	<ul style="list-style-type: none"> • Login in • User can enter a required information.
Test Data	User can view the prescription.
Expected Result	User can view the prescription.
Actual Result	View prescription
Status	Test Successful.
Created By	Ihtasham Akram
Date of Creation	24/12/18
Executed by	Ihtasham Akram

TEST CASE 7

Payment:

Test suite ID	S007
Test Case ID	C007
Actor	Register user
Test Case Summery	To verify payment button is functioning correctly.
Related Requirement	User must be successfully Login In Information of the User must be successfully entered. Information of the Source must be successfully entered. User can select doctor and get appointment.
Prerequisites	None
Test Procedure	User must login Select the item After sending the prescription payment module will be shown way a credit card.
Test Data	After sending the prescription payment module will be shown way a credit card.
Expected Result	Payment procedure will be completed.
Actual Result	Payment procedure will be completed.
Status	Test Successful.
Created By	Ihtasham Akram
Date of Creation	24/12/18
Executed by	Ihtasham Akram
Date of execution	24/12/18

TEST CASE 8

Logout:

Test suite ID	S003
Test Case ID	C003
Actor	Register user
Test Case Summery	To verify that Logout button is working when user click on it.
Related Requirement	Login user can Logout.
Prerequisites	None
Test Procedure	<ul style="list-style-type: none"> • When the user can Log in if he want to Logout. • Click Logout button
Test Data	<p>For Username Field: Jackson, Maize, Akon.</p> <p>For Password field: 12345, 2345, shields.</p> <p>Email: abc@gamil.com, xyz@gmail.com , wer@gmail.com</p> <p>Phone Number: 03314693456,03349229234,03149837434.</p>
Expected Result	<ul style="list-style-type: none"> • If the username and password are valid then the home page should be opened. • When User enters in invalid Email then message show “Your Email is invalid Please Enter the correct Email, Retry option”. <p>When User enters a wrong Password then message show “Your Password is invalid Please Enter the correct Password, Retry option”.</p>

	<ul style="list-style-type: none"> When the user want to logout then click on logout button.
Actual Result	Test Successful.
Status	Test Successful.
Created By	Ihtasham Akram
Date of Creation	24/12/18
Executed by	Ihtasham Akram
Date of execution	24/12/18

Doctor Side

Test case 1

Add doctor:

Test suite ID	S001
Test Case ID	C001
Actor	Admin
Test Case Summery	To verify add doctor button is functioning correctly.
Related Requirement	Admin can add doctor, update doctor profile and delete it.
Prerequisites	None
Test Procedure	Admin can add doctor, update doctor profile and delete it.
Test Data	None
Expected Result	Admin can add doctor.
Actual Result	doctor is added

Status	Test Successful.
Created By	Ihtasham Akram
Date of Creation	24/12/18
Executed by	Ihtasham Akram
Date of execution	24/12/18

6.1. Boundary value analysis

Analysis simply means selection value close to limits of the class.

We have these input classes.

- Less than equal to 5.
- Greater than 5.

6.2. Data flow testing

The flow test is the form of white box test and a texture test, which usually continue at the points where the data value received from the variables and the points where they are checked. The basic idea of this form of testing is the detection of errors and coding error.

Check if all the data variable present in programming code have been initialized.

- Make sure all condition are working properly.
- Make sure all condition are met in a define state.
- Check all the types and size of variable data correctly.
- Delete this line code that is not used in this project.

6.3. Unit testing

Tool used for unit testing

- Coded UI Testing

6.4. Integration testing

The integration test is performed to determine if the components interact with each other. Integration can be done after component testing. Check the modules to interact with other modules. The integration test is applied when creating a module. In the test technique, we tested the work of combining different modules. After the development of the modules, we integrate them and checked the behavior of the modules during the execution.

If all modules work properly if we integrate another module in which we integrate modules. We have tested the operation of the modules, it works after the integration of this system.

6.5. Performance testing

Performance testing is done manually. The main purpose of load testing is to check the response time and our application's portability power. Performance testing is done by performing multiple tasks at the same time.

6.6. Stress Testing

In this, we check the stability of our software. It is also done manually. We perform this testing by adding data to the database and by fetching many types of data from the database.

Appendices

Reference and Bibliography

Reference and Bibliography

- [1] P. T. S. J. Joseph, 2006, E-Commerce: An Indian Perspective 4 Edition 4th Edition
- [2] Shiven Dragupta, 2014, Introduction [online]. Available.
[https://www.slideshare.net/shivendragupta55/trustbuilding factors-in-ecommerce industry](https://www.slideshare.net/shivendragupta55/trustbuilding-factors-in-ecommerce-industry)
- [3]-----, 2014, Flowchart [online]. Available. <https://code2flow.com/app>
- [4]-----2014, summery, [online]. Available.
[https://www.bplans.com/hydroponics farm business plan/executive summary fc.php](https://www.bplans.com/hydroponics-farm-business-plan/executive-summary-fc.php)
[re](#)
- [5] By Ulf Eriksson 28th September 2012, Test case [online]. Available.
<https://reqtest.com/tutorials/how-to-develop-a-template-for-test-cases/>
- [6] -----, October 31, 2017, Sequence Diagram [online]. Available
[http://centreurop.info/sequence-diagram-template/sequence-diagram-template-sequence diagram-templates-to-instantly-view-object-interactions-free/](http://centreurop.info/sequence-diagram-template/sequence-diagram-template-sequence-diagram-templates-to-instantly-view-object-interactions-free/)
- [7] E draw Soft 2004-2018, Class Diagram [online]. Available
<https://www.edrawsoft.com/template-uml-class-diagram.php>
- [8] -----, 2016 Wiring Diagram, Network Diagram [online]. Available
<http://collagenrestores.com/basic-network-diagram-example-image/physical-networkdiagram-quickly-create-professional-physical-4/>
- [9]-----, 1993 — 2018 CS Odessa, Activity Diagram, [online]. Available
<http://www.conceptdraw.com/examples/activity-diagram-template>