

# SUPERIOR UNIVERSITY LAHORE

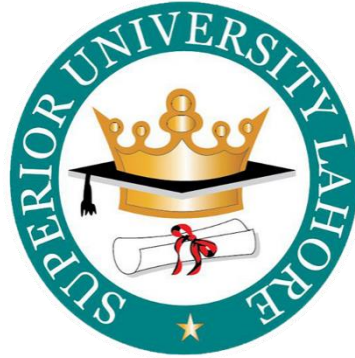

Faculty of Computer Science & IT

## Final Year Project PROJECT REPORT (Part-2)

Mobile application for Attendance System  
(MAAS)

Project ID:006

### Project Team

Student Name	Student ID	Program	Contact Number	Email Address
AHMAD abdul MOIZ	BITM-F14-48	BSIT	03200464596	ahmadabdulmoiz.pk@gmail.com

Mohammad Javaid Iqbal  
Lecturer

# Project Report

## MAAS

### Change Record

Author	Version	Date	Notes	Supervisor's Signature
Ahmad Abdul MOIZ	2.2.	06-11-2018	MAAS	
			Changes Based on Feedback from Supervisor : Android application for schools / Colleges	
			Project Plan : Deployment of this application in all around Lahore schools and Colleges and in future all around Punjab	
			Changes Based on Feedback from External Evaluator : Deploy Unit Tests for Admin / Lecturers/ Students and check database performance on huge data insertion phase and check access according to their predefined roles and responsibilities.	

## APPROVAL

---

### PROJECT SUPERVISOR

Comments: \_\_\_\_\_

---

Name: \_\_\_\_\_

Date: \_\_\_\_\_ Signature: \_\_\_\_\_

---

### PROJECT MANAGER

Comments: \_\_\_\_\_

---

Date: \_\_\_\_\_ Signature: \_\_\_\_\_

### HEAD OF THE DEPARTMENT

Comments: \_\_\_\_\_

---

Date: \_\_\_\_\_ Signature: \_\_\_\_\_

## **Dedication**

*This work is dedicated to My Parents*

*And*

*Mr.Javaid Iqbal... Supervisor...*

*who guide me step by step working at every level of difficulty.*

## **Acknowledgements**

We would like to present superior thanks to my supervisor, Mr. Javaid Iqbal who had guide me since the start of Project Report writing. Thanks to him for provide assistance, intelligence, and useful feedback about the final year project either in documentation parts or technical portions. In addition, guideline and briefing on how to create a good quality report for this project also provided to me.

## **Executive Summary**

Project is about to develop a student attendance system that based on mobile-based attendance of student in directive to verify their attendance with mobile application. Mobile application-based attendance system is developed for student in the purpose of to validate their attendance in all classes. At the same time, mobile application-based attendance system is developed for admin and lecturer to view and analyze student attendance by produce the attendance report. The main purpose to develop this project is to replace the existing traditional attendance system by provide faster, accurate, and efficient system. With this new mobile-based attendance method, it can solve some problems such as buddy signing, loss of attendance sheet, and control student miss class rate. This project, evolutionary prototyping had been applied as methodology that guides the direction of whole project development. Other than that, system analysis and design technique is used to demonstrate necessary diagrams for purpose to demonstrate the whole system in more accurate way. Lastly, the application of this system absolutely providing more efficient, reliable, and accurate way to accomplish the student attendance data.

## Table of Contents

<a href="#">Dedication</a> .....	iv
<a href="#">Acknowledgements</a> .....	v
<a href="#">Executive Summary</a> .....	vi
<a href="#">Table of Contents</a> .....	vii
<a href="#">List of Figures</a> .....	x
<a href="#">List of Tables</a> .....	xi
<a href="#">Chapter 1</a> .....	13
<a href="#">Introduction</a> .....	13
<a href="#">1.1. Background</a> .....	14
<a href="#">1.2. Motivations and Challenges</a> .....	15
<a href="#">1.3. Goals and Objectives</a> .....	16
<a href="#">1.4. Literature Assessment</a> .....	17
<a href="#">1.5. Proposed Solution</a> .....	23
<a href="#">1.6. Project Plan</a> .....	23
<a href="#">1.6.1. Roles &amp; Responsibility Matrix</a> .....	24
<a href="#">1.6.2. Gantt Chart</a> .....	27
<a href="#">1.7. Report Outline</a> .....	27
<a href="#">Chapter 2</a> .....	28
<a href="#">Software Requirement Specifications</a> .....	28
<a href="#">2.1. Introduction</a> .....	29
<a href="#">2.1.1. Purpose</a> .....	29
<a href="#">2.1.2. Intended Audience and Reading Suggestions</a> .....	29
<a href="#">2.1.3. Product (MAAS) Scope</a> .....	30
<a href="#">2.2. Overall Description</a> .....	30
<a href="#">2.2.1. MAAS Perspective</a> .....	30
<a href="#">2.2.2. MAAS Functions</a> .....	31
<a href="#">2.2.3. Operating Environment</a> .....	31
<a href="#">2.2.4. Design and Implementation Constraints</a> .....	32
<a href="#">2.2.5. Assumptions and Dependencies</a> .....	33
<a href="#">2.3. External Interface Requirements</a> .....	33
<a href="#">2.3.1. User Interfaces</a> .....	33
<a href="#">2.3.2. Hardware Interfaces</a> .....	33
<a href="#">2.3.3. Software Interfaces</a> .....	34
<a href="#">2.3.4. Communications Interfaces</a> .....	34
<a href="#">2.4. System Features</a> .....	34
<a href="#">2.4.1. Adding a New student</a> .....	34
<a href="#">2.4.1.1. Description and Priority</a> .....	34
<a href="#">2.4.1.2. Functional Requirements</a> .....	34
<a href="#">2.4.2. Use the MAAS to Call attendance in classes</a> .....	34

2.4.2.1. <a href="#">Description and Priority</a> .....	34
2.4.2.2. <a href="#">Functional Requirements</a> .....	34
2.4.3. <a href="#">Report students</a> .....	35
2.5. <a href="#">Other Nonfunctional Requirements</a> .....	35
2.5.1. <a href="#">Safety Requirements</a> .....	35
2.5.2. <a href="#">User Access</a> .....	36
2.5.3. <a href="#">Business Rules</a> .....	36
<a href="#">Chapter 3</a> .....	37
<a href="#">Use Case Analysis</a> .....	37
3.1. <a href="#">Use Case Model</a> .....	39
3.2. <a href="#">Fully Dressed Use Cases</a> .....	40
<a href="#">Chapter 4</a> .....	49
<a href="#">System Design</a> .....	49
4.1. <a href="#">Architecture Diagram</a> .....	51
4.2. <a href="#">Entity Relationship Diagram with data dictionary</a> .....	52
4.3. <a href="#">Activity Diagram</a> .....	56
4.4. <a href="#">Sequence Diagram</a> .....	59
4.5. <a href="#">Component Diagram</a> .....	59
4.6. <a href="#">Class Diagram</a> .....	60
4.7. <a href="#">DFD Level 0 Context Diagram</a> .....	61
<a href="#">Chapter 5</a> .....	64
<a href="#">Implementation</a> .....	64
5.1. <a href="#">Important Flow Control/Pseudo codes</a> .....	65
5.2. <a href="#">Deployment Environment</a> .....	66
5.3. <a href="#">Tools and Techniques</a> .....	66
5.4. <a href="#">Version Control</a> .....	66
<a href="#">Chapter 6</a> .....	67
<a href="#">Testing and Evaluation</a> .....	68
6.1. <a href="#">Use Case Testing</a> .....	69
6.2. <a href="#">Equivalence partitioning</a> .....	70
6.3. <a href="#">Boundary value analysis</a> .....	70
6.4. <a href="#">Data flow testing</a> .....	71
6.5. <a href="#">Unit testing</a> .....	72
6.6. <a href="#">Integration testing</a> .....	74
6.7. <a href="#">Performance testing</a> .....	76
6.8. <a href="#">Stress Testing</a> .....	78
<a href="#">Chapter 7</a> .....	80
<a href="#">Summary, Conclusion and Future Enhancements</a> .....	81
7.1. <a href="#">Project Summary</a> .....	82
7.2. <a href="#">Achievements and Improvements</a> .....	84
7.3. <a href="#">Critical Review</a> .....	86
7.4. <a href="#">Lessons Learnt</a> .....	87
7.5. <a href="#">Future Enhancements/Recommendations</a> .....	89

<a href="#">Reference and Bibliography</a> .....	10
<a href="#">References</a> .....	11

## List of Figures

Figure 1.4.1. Rate of Student who helps Friend Sign Attendance .....	16
Figure 1.4.2. Rate of Participants that Skip Class .....	17
Figure 1.4.3. Skip Class Factors of Participants.....	17
Figure 1.4.4. Personal Academy Result based on Attendance Rate .....	18
Figure 1.4.5. Rate of Participants Satisfied with Current System .....	20
Figure 1.4.6. Rate of Participants think Current System should be Replaced .....	21
Figure 1.4.7. First Reaction toward MAAS-Attendance System .....	22
Figure 3.1.1. Use Case Diagram for MAAS.....	39
Figure 3.2.1. Keep Track of Personal Attendance Record Use-Case Description.....	40
Figure 3.2.2. Check-in Attendance Use-Case Description .....	41
Figure 3.2.3. Manage Time Late Policy Use-Case Description ... ..	43
Figure 3.2.4. Manage Communication Methods Use-Case Description .....	44
Figure 3.2.5. Search Attendance History Use-Case Description .....	47
Figure 3.2.1.1: Use Case Diagram for Student.....	48
Figure 3.2.1.2: Use Case Diagram for Administrator.....	48
Figure 3.2.1.3: Use Case Diagram for Teacher.....	49
Figure 4.1.1: MAAS System Diagram .....	50
Figure 4.1.2: MAAS Architectural Diagram.....	51
Figure 4.1.3: MAAS ERD Diagram .....	52
Figure 4.3.1: Activity Diagram1 .....	55
Figure 4.3.2: Activity Diagram2 .....	57
Figure 4.3.3: Activity Diagram3 .....	59
Figure 4.4.1 Sequence Diagram.....	61
Figure 4.5. Component Diagram for MAAS.....	62

## List of Table

Table 1.4.1: Comparison Table of Attendance Systems.....	15
Table 1.6.1.1: Table of Roles and Responsibilities .....	22
Table 4.3.1: Table of Student .....	55
Table 4.3.2: Table of Subject .....	55
Table 4.3.3: Table of Lecturer .....	56
Table 4.3.4: Table of Classroom.....	57
Table 4.3.5: Table of Attendance .....	57
Table 4.3.6: Table of Subclass .....	58
Table 4.3.7: Table of Class_Hour.....	58
Table 4.3.8: Table of Class_Detail.....	58
Table 5.3.1. Hardware requirements.....	62
Table 5.3.2. Software requirements.....	62
Table 6.1.1. Corresponding Unit Test Case for 'Admin' case.....	66
Table 6.1.2. Corresponding Test Case for 'Student' case.....	66
Table 6.1.3. Corresponding Test Case for 'Teacher' case.....	67
Table 6.4.1. Login as Users (Admin, Lecturer, Student).....	70
Table 6.4.2. Login as Users (Admin, Lecturer, Student).....	71
Table 6.4.3. Edit Personal Profile (Admin, Lecturer, Student).....	73
Table 6.4.4. Create User Profile (Admin).....	75
Table 6.4.5. Create New Classroom (Admin).....	76
Table 6.4.6. Create Student and Class Enrollment (Admin).....	77
Table 6.4.7. Class Details with Student Details(Lecturer).....	80

*This Page is initially blank...*

# Chapter 1

## Introduction

## Chapter 1: Introduction

This project is about to study and improve a student attendance system that based on mobile-based attendance of student in order to confirm their attendance with mobile application. In this system, mobile application-based attendance system has been developed for student for a purpose to authenticate their attendance in all classes. At the same time, mobile application-based attendance system has been developed for admin, lecturer to view and analyze student attendance by produce the attendance report. The main purpose to develop this project is to replace the present traditional attendance system by deliver faster, accurate, and efficient system. With this new mobile-based attendance system, it can remove some problems such as buddy validation, loss of attendance sheet, and control student miss class rate.

### 1.1. Background

Student academic attendance is very important since it is shake the students from gaining knowledge and skills as well as their grades. This project has associated about the student attendance system mobile-application based to check their attendance. The main purpose of carrying out this project is to improve a student attendance system for which mobile-based application is established to obtain the attendance of student by mobile-application based and post/review the attendance outcomes using mobile-application-based student attendance system. Nowadays, most universities and colleges are still using the outdated attendance system which wants student to sign on a piece of paper every time they attend a class throughout the whole class duration. Using the old-style attendance system, we can obviously see that there are few difficulties such as it is be no backup for the attendance accounts once the lecturer accidentally misplaced or loss the attendance sheet, course mate help those who did not appear the class sign the attendance which also known as buddy-signing as well, hard in examining and tracking student presentations based on attendance factor, student lack of knowledge and skills due to the unfortunate attendance in attending classes, and etc. It is important to overcome these problems since it help in improving the academic act of students as well as the teaching environment of the lecturers. Hence, the purpose of carrying out this project is to prevent undesirable situation occur and to find out

Superior University Lahore, Pakistan

the problems that bases these problems as well as find the solutions to overcome these problems. Thus, through the problems evaluated, the objective of this project is to advance a mobile-apps-based student attendance system in recording their attendance efficiently in every class in order to avoid student skip classes. Next, the developed system provide the report generation concerning to the student attendance in order to assist the lecturer/staff in examine and tracking the student attendance. By implementing the developed system, lecturers no more facing the blank classroom every time while they are lecturing in front the stage. In addition, it is easier to evaluate and analyze the student act based on their attendance since the system is recording the attendance more precisely and efficiently with minimum probable error. Furthermore, student academic performance is increased as well since they cannot bogus their attendance through the developed system which means they have to attend all the classes in order to avoid them from get bar. Last but not least, the system has contained several modules which are attendance module, email segment, report module, schedule part, lecturer module, student module, and etc. in order to ensure the system can help in improving the student attendance as well as provide the precise and effective information[1].

## **1.2. Motivations and Challenges**

The inspiration to develop this project is to solve some problems that are currently happening in every schools/colleges. This project purpose is to advance the current paper-based traditional attendance management system that is still in use by many schools and colleges. From the opinion, most of the problems found are normally caused by the use of old-style attendance system in these many schools and colleges. Therefore, a mobile app-based student attendance management system has been developed in order to resolve these problems.

Since most of the schools/colleges still using the traditional attendance system, so, a bold statement is made which most of the problems faced by these schools/colleges are almost same. In addition, this project is able to reduce the load of every lecturer in key-in the student's attendance records to the system at every end of class since this system record all student's attendance precisely and routinely in every classes attended by students throughout the whole classes. Moreover, students have paid the colleges/universities in order to advance knowledge that helps them in building up their future career. Therefore, every schools/colleges must provide the responsibilities in ensuring their students surely attend all the classes for the subjects they had registered.

### 1.3. Goals and Objectives

In evolving this system, some project purposes had been specified. The main purpose of this project is to advance the current existing student attendance system that in use by most of the schools/colleges by develop a mobile application-based student attendance management system. Some objectives of this project had been famous and listed below.

- To replace the current existing student attendance system process to fully-mobilized and automated student attendance structure.
- To develop a mobile application-based student attendance system in showing every student attendance results efficiently.
- To generate reports regarding to the student attendance in order to help the lecturer/staff in examine and tracing the student attendance.
- To eliminate the risks for student to ask their buddy sign attendance for them through the implementation of photo comment in attendance system.

## 1.4. Literature Assessment

A literature review or assessment can be denoting to as a review of current system that the researcher had done before and the review of the system that is developed.

Literature review also concentrations on the knowledge and ideas established on a topic as well as their strong point and flaws. Nowadays, technology is getting better and better to replacing the outdated system to speed up the process by introducing the mobilized system. There are few types of attendance system that had been introduced nowadays in school, college, and university[2].

**Table 1.4.1. Comparison Table of Attendance Systems**

Comparisons Structures	Unique Identifier	Remove Buddy-Signing	Student Lateness Detection	Perfect and efficient attendance records	Save Time	Email Notification	Report Generation
1 Student Attendance . Management	NO	NO	NO	NO	NO	NO	NO
2 RFID Based Attendance . Management System	NO	NO	YES	YES	YES	NO	NO
3 Bar Code Scanner Based . Student Attendance System (SAS)	NO	NO	NO	YES	YES	NO	YES
4 Integrated System for . Checking and Recognizing Students during Class Session	YES	YES	NO	NO	NO	NO	YES
5 Wireless Attendance . Management System based on Iris Recognition	YES	YES	NO	YES	YES	NO	NO
6 A Low-cost Remote . Attendance Tracking System for Developing Regions	YES	NO	NO	NO	NO	NO	YES
7 MAAS	YES	NO	Yes	YES	YES	NO	YES

### 1.4.1 Data Collection

Data collection can be stated to as the process use to collect and amount relevant data needed to justify the research problems, importance of the solutions, and value outcomes. Data collection is a very important phase in carrying out a study. Without performing data collection, no matter how good the system is designed, the student may still not be able to complete the study. There are two types of data in the data gathering which named quantitative data and qualitative data.

According to the survey that had directed, 40 sets of survey (15 questions per set) were ready for students to fill up in order to find the data regarding the student attendance system. The forms are distributed to few different students and are conducted inside Different Schools of Lahore. Questions inside the forms are prepared to focus/analyze on few things which include the problem study, current attendance system analysis, and new MAAS system examination. Through the data collected, analysis was passed out justify the problems and need for solutions.

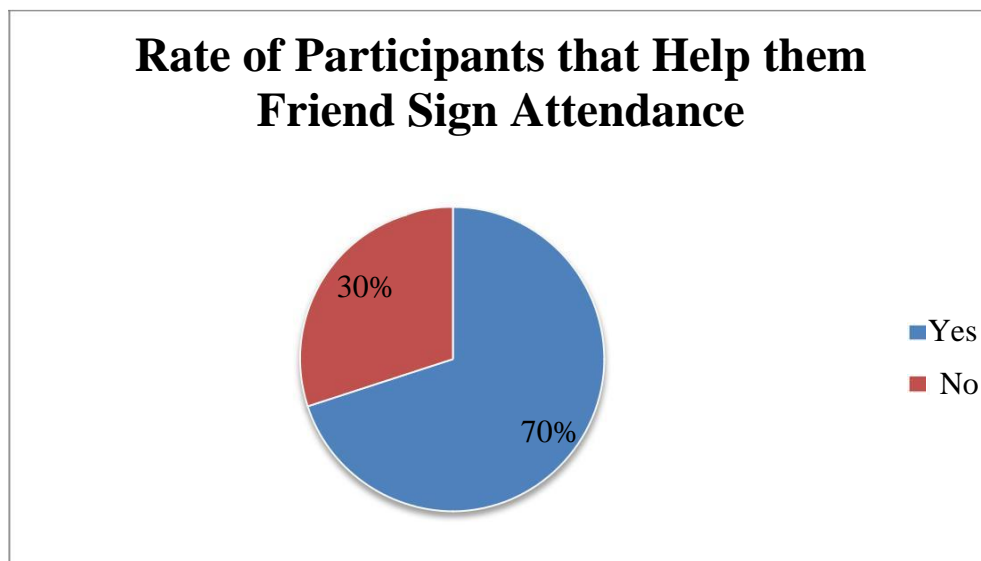
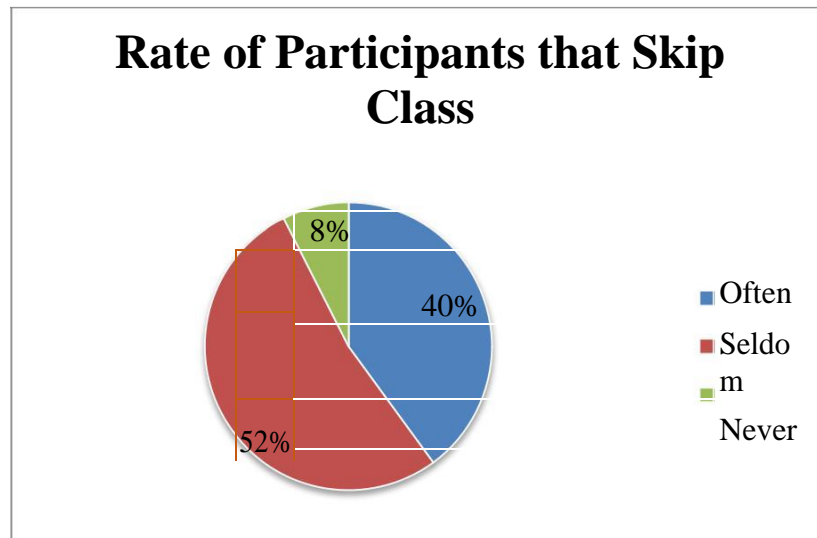

Figure 1.4.1. Rate of Student who helps Friend Sign Attendance

According to the Figure 1.4.1., the data composed shows that the rates of participants who help their friends sign the attendance while they inattentive from class had reach up to 70% while only 30% of them underline that they never sign for their friends.

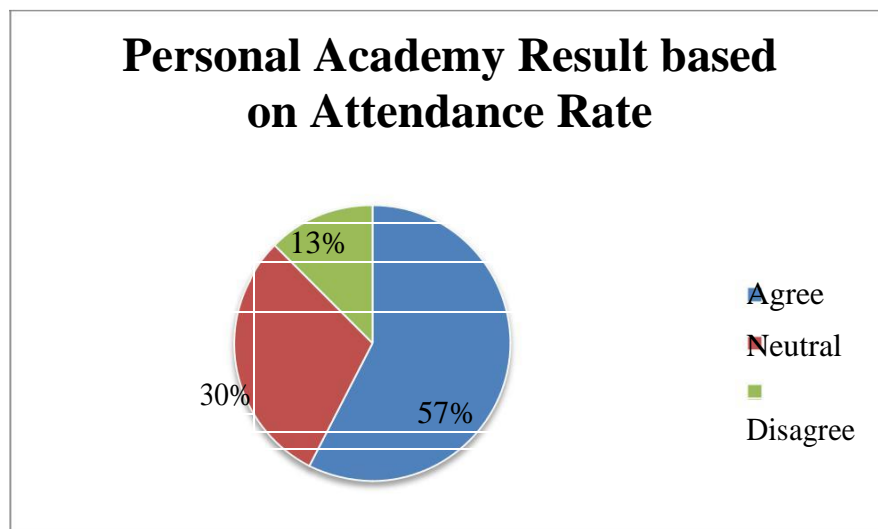

**Figure 1.4.2. Rate of Participants that Skip Class**

Next, the information composed shown that 40% of them are always miss class. While 52% of them highlight that they rarely skip class following by the 8% of students underscore that they never skip class.

According to the data together, it can be clearly seen that there are some major features that causes the student to miss the class. Results shown that 45% of the contributors choose to skip class because they did not sufficient sleep following by the factors of hanging out with people (32%), hastening for assignment (15%), study for another paper test (8%), and other reasons (0%). Other than that, there are others sub-factors that causes the student unable to sign the attendance which contain forgotten.

According to the data composed, it shows that 70% of the participants never be unable to remember to sign their attendance while 30% of them had encountered this problem before. In addition, data collected also shows that there are 90% of students who never try to make lost the attendance paper to avoid being streaky due to poor attendance while 10% of them had tried to do so. Besides that, 52.5% of students highlight that they had encountered a problem which they attended the class but attendance wasn't updated while 47.5% of them emphasize that they never facing this problem.



**Figure 1.4.4. Personal Academy Result based on Attendance Rate**

Next, data shows that 57% of contributors believe that attendance record is affect their personal school/college result which means presence the class is very important in obtaining good academy result. While 30% of them underline there is no differences between attending the class or not in order to obtain good academy result following by 13% of them are disagree with the statement.

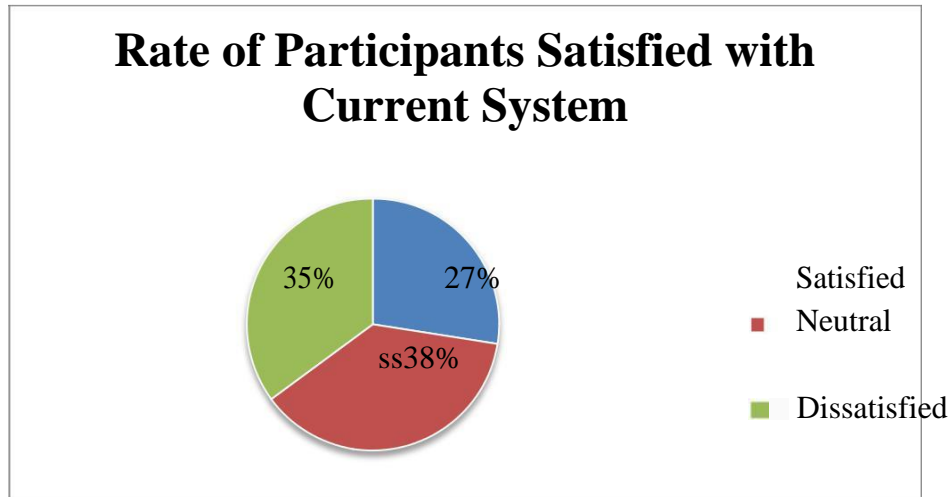

**Figure 1.4.5. Rate of Participants Satisfied with Current System**

From the composed data, it shows that only 27% of participants are satisfied with current attendance system while 35% of them displeased with the current system and 38% of them give dispassionate response. Other than that, data also shows that 65% of them agree that the current system is very distressing when there are large number of students in a class since they need to pass the paper-attendance around the whole class. Data shows only 10% of them disagree that the current system is difficult while 25% of them give neutral response.

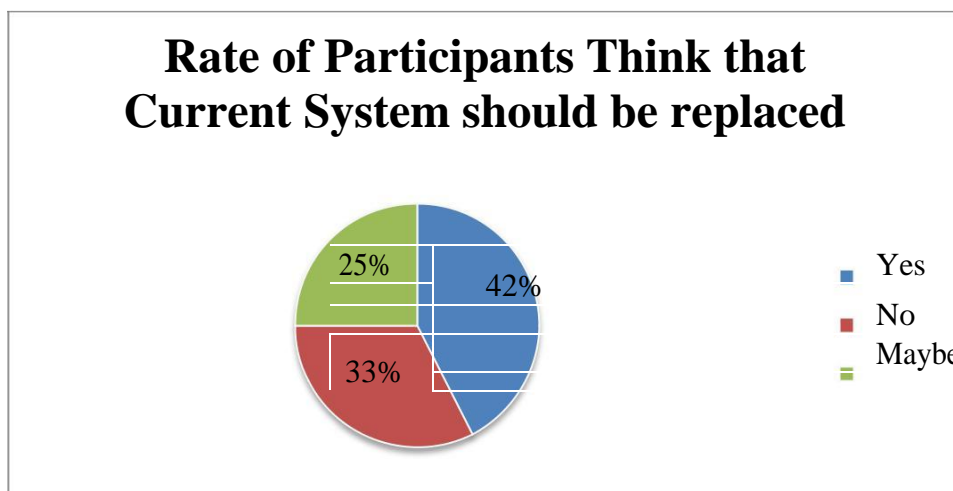

**Figure 1.4.6.: Rate of Participants think Current System should be Replaced**

The data shown indicates that 42% of the participants agree that the current system should be replaced while only 33% of them disagree with this statement following by 25% of them are waver whether the system should be replaced or not.

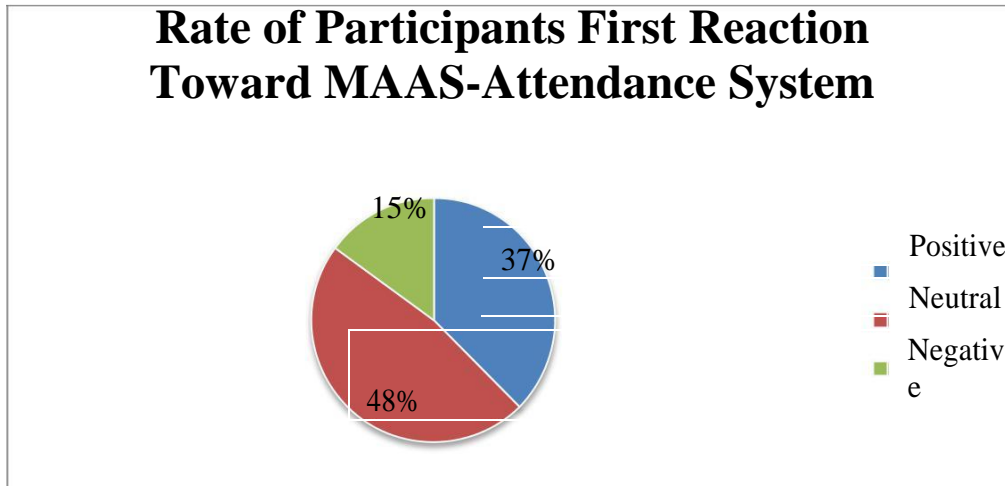

**Figure 1.4.7.: First Reaction toward MAAS-Attendance System**

Besides that, data collected also shows that 37% of the contributors give out positive reaction to the new MAAS-attendance system while 48% of them keep neutral answer following by 15% of them give negative reply regarding this problem. Moreover, students had given answer according to the injustice of current attendance system. In short, 70% of them agree the opportunity of student absent from class can be reduces since it become hard to trick the lecturers by relating the new attendance system. Another 10% of members disagree with this statement while 20% of them give neutral reply.

After go through the whole data gathering process, some difficulties are clearly seen in current student attendance management system. Due to the examination, it had shown that the new MAAS-attendance system should be conduct to overcome these problems marked from the survey. In short, most of the problems are likely can be solve by implementing the new system. Therefore, this project should be conduct.

## 1.5. Proposed Solution

To replace the current existing student attendance system process to fully mobilized and automated student attendance system. To develop a mobile-based Attendance application to develop a mobile-based student attendance system in displaying every student attendance results effectively. To generate reports regarding to the student attendance in order to assist the lecturer/staff in analyze and tracking the student attendance.

Time accuracy Deployment, Weekly Report Generation

To provide easier method in evaluate and analyze the student performance based on their attendance since the system record the attendance more accurately and efficiently with minimum possible error.

## 1.6. Project Plan

	Description of Work	Start and End Dates
<b>Phase One</b>	Planning	11-12-2017
<b>Phase Two</b>	Designing phase	6-02-2018
<b>Phase Three</b>	Final Documentation	7-06-2018

## 1.6.1. Roles & Responsibility Matrix

**Table 1.6.1.1.: Table of Roles and Responsibilities**

WBS #	WBS Deliverable	Activity #	Activity to Complete the Deliverable	Duration (# of Days)	Responsible Team Member(s) & Role(s)
1	Requirement gathering	1	<ul style="list-style-type: none"> <li>• Interviews</li> <li>• Research</li> <li>• Competitors Analysis</li> <li>• Purify feasible requirements.</li> </ul>	15 days	<u>Ahmad abdul MOIZ</u>
2	Establish Design	2	<ul style="list-style-type: none"> <li>• Design Wire Layout</li> <li>• Try Different Color Schemas</li> <li>• Design Logo, Icons, Header, Footer, Slider.</li> <li>• Implement design for responsive mobile apps</li> </ul>	20 days	<u>Ahmad</u> : Do all designing work and also implement front-end for mobiles apps. Do implement that design through Adobe Photoshop to Android
3	Admin Module	3	<ul style="list-style-type: none"> <li>• Design Admin Module</li> <li>• Design every activity of admin</li> <li>• Implement of design and all activities</li> <li>• Apply and perform all operations in activities</li> </ul>	17 day	<u>Ahmad</u> :Do all implementation through java. <u>Ahmad</u> : Design the module and all activities.
4	Student Module	4	<ul style="list-style-type: none"> <li>• Design Student Module</li> <li>• Design every activity of student</li> <li>• Implement of design and all activities.</li> <li>• Apply and perform all operations in activities</li> </ul>	20 days	<u>Ahmad</u> Do all implementation through java + css <u>Abdul MOIZ</u> Design the module and all activities. <u>Taha</u> : Do perform all operations.

5	Admin-Student relation Module	5	<ul style="list-style-type: none"> <li>• Design Admin-Student relation Module</li> <li>• Design every activity of Admin-Student relation</li> <li>• Implement of design and all activities.</li> <li>• Apply and perform all operations in activities</li> </ul>	15 days	<p><u>Ahmad</u>: Design life cycle activities for students</p> <p><u>Taha</u> : Design life cycle activities for Teachers and admin</p>
6	Database Module	6	<ul style="list-style-type: none"> <li>• Define data entities and their usage.</li> <li>• Identify relations between entities</li> </ul>	10 days	<p><u>Ahmad</u>: Define data entities and also define relations between them.</p> <p>Taha: Define relations between entities.</p>
7	Product Management Module	7	<ul style="list-style-type: none"> <li>• Design Product Module</li> <li>• Design every activity for MAAS application.</li> <li>• Implement design and activities</li> </ul>	15 days	<p><u>Ahmad</u> Design every activity for MAAS Application</p> <p>Implement design and activities</p>
8	Services	8	<ul style="list-style-type: none"> <li>• Identify and design services.</li> <li>• Implement services.</li> </ul>	10 days	<p><u>Ahmad</u>: Design and implement REST Services.</p>
9	Testing	9	<ul style="list-style-type: none"> <li>• Test every single module.</li> <li>• Integration test for every module.</li> <li>• Apply different security algorithms then check manually and through tools.</li> </ul>	120 days	<p><u>Ahmad</u>: Do Unit and Integration testing.</p> <p><u>Ahmad</u>: Do Security and Performance testing.</p> <p><u>Ahmad</u>: Do load testing.</p>

			<ul style="list-style-type: none"> <li>• Check performance, load testing through tools.</li> </ul>		
10	Documentation		<ul style="list-style-type: none"> <li>• Document each and everything from the beginning of the project to the end.</li> <li>• SRS</li> <li>• SDS</li> <li>• Reported Bugs and issues</li> <li>• User Document</li> </ul>	50 days	<u>Ahmad</u> : Make SRS <u>Ahmad</u> : Make Design Documentation <u>Ahmad</u> : Testing Documentation and User documentation
11	Launch Product	10	<ul style="list-style-type: none"> <li>• Buy Account.</li> <li>• Launch Application.</li> </ul>	7 days	<u>Ahmad abdul MOIZ</u>

## 1.6.2. Gantt Chart

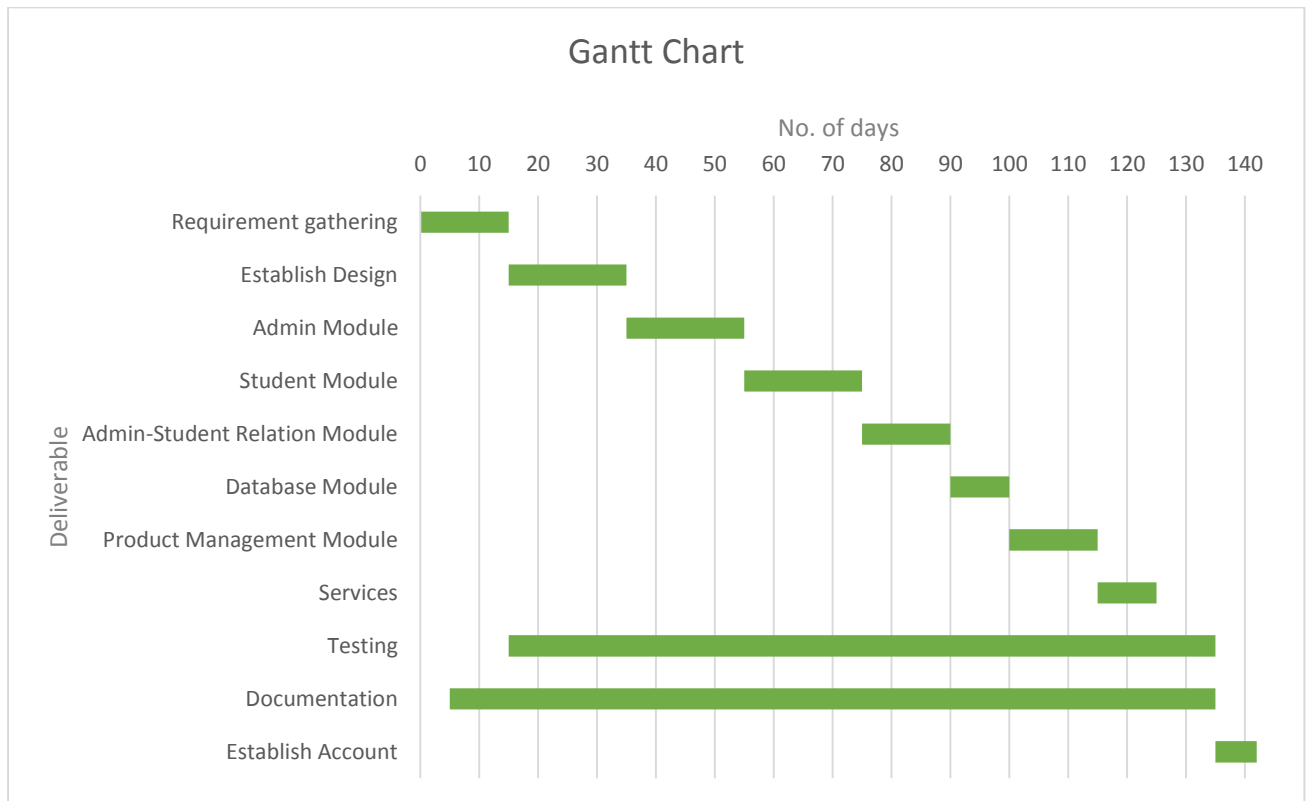

Figure 1.6.2.1: Gantt chart for MAAS

## 1.7. Report Outline

In conclusion, mobile-application based attendance system has been developed to replace the traditional attendance system that are currently widely using by many colleges and universities. This project considered succeed once hybrid student attendance is developed. This system is designed to make the whole attendance taking process to become more reliable, convenient, efficient, and accurate. Besides that, with the implementation of mobile-application based attendance system is help in reduce errors and attendance data is be able to compile in easier way.

# Chapter 2

## Software Requirement Specifications

## **Chapter 2: Software Requirement Specifications**

### **2.1. Introduction**

#### **2.1.1. Purpose**

The main purpose of this specification is to help schools and colleges who work on this system to maintain the objectives and get started working easier by mobile based attendance system. This specification to direct staff/teachers who get effective response by this project. This statement is described specific details into every step of this project that workers immediately locate the needs of this system to understand the purpose of doing any of the following steps into the system.

#### **2.1.2. Intended Audience and Reading Suggestions**

The audiences of this system are Define below:

1. Students
2. Faculty members
3. Registration office.
4. Parents

This project be managed by registration office as admin, teachers as update and manage student record and students to easy view their attendance record and much more according to development such as monthly report of attendance and results of all tests.

### **2.1.3. MAAS Scope**

The project scope of this project is to develop a mobile based student attendance management system with photo comment and sharing data with administration. In this project, mobile based student attendance system developed of students who attend the class. In addition, mobile based student attendance system developed for purposes to display the attendance status/condition of every student, generate reports related to the student attendance, and etc. Besides that, proper planning are carried on in order to perform this project by using the project methodology that had been chosen.

Next, the student attendance management system only developed for managing the student attendance status and allow lecturers/faculty staffs to easily analyze the information regarding the student attendance. In other words, it means that this attendance system only cover the functions related to student attendance but not any others function related to another thing. The purpose to carry out this system is to overcome the current problems in their current attendance system facing by the school and colleges. There are some modules covered in the product scope[3].

## **2.2. Overall Description**

### **2.2.1. MAAS Perspective**

At mostly schools and colleges of Lahore in first preferences and all-around Punjab or Pakistan attendance system still in paper based and have no back up if sheets lost and parents have not knowledge about their children performance, instructors manually take attendance in every class each day by MAAS android attendance application. They spend time to do that during class time. The MAAS Attendance System help them do this process in an easy way. The main scope of this project is to make attendance process more organized in every class by MAAS android app. This project help instructors take the attendance automatically without spending some time during the class.

### 2.2.2. MAAS Functions

Students: This means students who get the most benefits of the system.

Faculty: Also, who has the top priority to get benefit for the system and they are the target actors of the system.

The Registration Office: This is for the system management, and it is presenting by the employees.

### 2.2.3. Operating Environment

Before starting to develop the attendance system, the necessarily development tools must be downloaded and installed to the devices used for system development. Therefore, Android Studio, SQLite, Google Chrome, and etc. was downloaded and installed for system development purpose. The process quite time-consuming since every development tool is need to perform the configuration needed during the installation. Although it is quite time-consuming, but this step can be seen as a very important step before the development begins.

After all the development tools installation done, the next thing to do is to configure and create table entity of the database. Based on the system design, the database is created to be used for later data storage. By using the SQLite, the database can be easily created since developer just need to key in the queries in order to create a new table. Many features are provided by the SQLite which ease and reduce the burden of developer in creating database[4].

The current system work is already in existence. However, we need some system requirements:

- 1) Create new databases and indexes for students and class list by using MySQL
- 2) Make connection to the current database
- 3) Design interfaces for the users
- 4) Design an attendance page on android studio 3.0 2017 Latest version.
- 5) Programming using JavaScript, PHP, and HTML

## 2.2.4. Design and Implementation Constraints

The whole process would be in this relationship as one part of the work, and it has everything we need to get the project started as planned. Entity relationship diagrams help this project to be clearer and more understandable. This is continue working on the same steps that we use in this diagram. The overall benefit of this structure is to facilitate easy communication between humans and computers. Better communication is expedite the desired results.

### Manage Student Information

Add the new student record into system. The student successfully registered to study in the college the student profile is added into STUDENT table. Edit the latest student details into the system if there are any changes. The student data already exist in the system The student profile is updated into STUDENT table. Delete the student details from the system. Add the new lecturer record into system. The lecturer successfully employed to teach in the college.

### Manage Lecturer Information

Edit the latest lecturer details into the system if there are any changes. The lecturer data already exist in the system. The lecturer profile is updated into LECTURER table. Delete the lecturer details from the system. The lecturer data already exist in the system. The lecturer profile is deleted from the LECTURER table.

### Add Class Period

Add the new class period into system. The CLASS\_DETAILS must be created first before the CLASS\_HOUR. The CLASS\_HOUR profile is added into CLASS\_HOUR table.

### Update Class Period

Edit the latest classHrs details into the system if there are any changes. The CLASS\_HOUR data already exist in the system. The CLASS\_HOUR profile is updated into CLASS\_HOUR table.

### Delete Class Period

Delete the classHrs details from the system. The CLASS\_HOUR data already exist in the system. The CLASS\_HOUR profile is deleted from CLASS\_HOUR table.

### Add Subject

Add the new subject into application. The subject is allowed to teach in the college. The subject profile is added into SUBJECT table.

### Update Subject

Edit the latest subject details into the system if there are any changes. The subject data already exist in the system. The subject profile is updated into SUBJECT table.

Delete Subject

Delete the subject details from the system. The subject data already exist in the system. The subject profile is deleted from the SUBJECT table.

Check-in Attendance

Check-in attendance into the system. The student wants to check-in his/her attendance. The attendance status successfully updated into system.

### 2.2.5. Assumptions and Dependencies

Different Projects deploy in schools and colleges. Many projects for attendance management such as web based, finger print based attendance management deploy in organization but our schools and colleges still on paper based systems so I would like to create MAAS which gives efficient and fast attendance and student / teachers monitoring system by generating weekly/monthly/annual report .

## 2.3. External Interface Requirements

### 2.3.1. User Interfaces

- ❖ Login Display For admin, teachers and students.
- ❖ Welcome View activity
- ❖ Add a New student
- ❖ Student Report
- ❖ Faculty Attendance Report
- ❖ Missed class activity

### 2.3.2. Hardware Interfaces

It's used for administration office

**Table 2.3.2.-F1 HR**

Hardware Description	Minimum Requirements
Processor	Intel Core i3 Dell 64 bit
Memory	1 GB RAM Recommended
Hard disk space	Up to 3 GB Recommended

### **2.3.3. Software Interfaces**

Android Studio 3.0 2017 latest version.

SQLite

Languages used: Java, HTML, CSS.

Microsoft Visio Professional 2013.

### **2.3.4. Communications Interfaces**

The requirements associated with any communications functions required by **MAAS**, include e-mail, web browser, server communications online based on any communication security or encryption issues define by application as admin control to modify or assign any activity, data transfer rates based on internet speed and synchronization mechanisms by android application based.

## **2.4. System Features**

### **2.4.1. Adding a New student**

#### **2.4.1.1. Description and Priority**

Function: Sign up a new student to the system

#### **2.4.1.2. Functional Requirements**

To add a new user to the system, all of them should have registered in the admission office before they can register in their classes. On the orientation day, all students must check their roll no for registration

### **2.4.2. Use the MAAS to Call attendance in classes**

#### **2.4.2.1. Description and Priority**

Function: Attend to classes

#### **2.4.2.2. Functional Requirements**

Requirements: When students have a class, , students said to yes when call by teacher in the class, and they are checked.

### 2.4.3. Report students

Function: The user can look at their reports for the current status.

#### 2.4.3.1 Functional Requirements

Requirements: When the students have enrolled in the class, they are now able to check on their current attendance situation through the MAAS page. In the system, they is be shown a page that gives them the whole attendance status in the class.

#### 2.4.4 Faculty receive a report

: Faculty receives a current report every class.

##### 2.4.4.1 Functional Requirements

Requirements: The system is send a message after ten minutes of the class time to the faculty. Faculty is have the all students' attendance reports in the particular class. Faculty can modify some of the attendance grades if he/she needs.

## 2.5. Other Nonfunctional Requirements

### 2.5.1. Safety Requirements

#### The Current System Security

The current system, android application-based attendance system, has its policy on its site page. The current system builds upon a user name and password access. Students and faculty can access to his/her account through their page, and they can control it. The system now has its own policy and security; however, the new feature we is add to the system is need some security requirements to the system.

The new feature in the system is add some values to the current policy to maintain the security in the right way. It also provides proof of compliance. The new policy in the system is deal with the security in many cases. The security is have more components on the system in a high control panel. The plan is to secure the outsider and insider community of misused the system (e.g. identification theft). Strong security is part of the policy's purpose.

### **2.5.2. User Access**

Inside the community, there are students, faculty, and registration office staff who are going to use the system. The main actor of the users in the entity is students. Students use the entity every day in each class. Faculty only use the system through MAAS app, and they can access student information. The faculty member uses the entity to control the attendance page. Faculty's job is to add, edit, update and delete any record. Furthermore, registration office staff check on every student's identification for security purposes. They check on students for identification in person before they add, edit, update and delete any information. The staff asks students for ID for identification.

### **Software Quality Attributes**

Quality characteristics for the MAAS are: adaptability, availability as smart phones are common it's easy to access MAAS app mostly used android system, correctness easy by mobile based, flexibility also available, interoperability, maintainability easy to maintain MAAS app, reliability as it's reliable but with little bit errors, reusability may be hard to reuse app in other deployment machine with some possible errors, and usability.

### **2.5.3. Business Rules**

I chose Gorilla Marketing strategy to target schools and colleges to deploy MAAS application in their organization to enhance working capability and student's efficiency by discussing weekly, monthly and annually reports.

# Chapter 3

## Use Case Analysis

## Chapter 3: System Analysis

In describing how the project is designed, diagrams is be sketch in this session to make clear on how the project is be written, how it functions, how it installs, and etc. In previously, I have studied the Object-Oriented System Analysis and Design (OOSAD). Therefore, this session is include all the diagrams that I had learnt from the OOSAD subject. The diagrams included are use-case diagram, activity-flow diagram, entity-relationship diagram, sequence diagram, object diagram, and etc. With the help of the diagrams, it is be able to assists the readers to understand more easily regarding the new system.

Other than diagrams, the database design is also be performed in this session for a purpose to specify all the required entities in this system. These also include the CRC cards, use-case description, and etc. In addition, drawing prototype of whole system interface is be included in this session to give a clear image to the reader/user how the system is look like and how it is function. The purpose of the drawing prototype is to obtain initial feedback from the reader/user before the first real prototype begins development.

### 3.1. Use Case Model

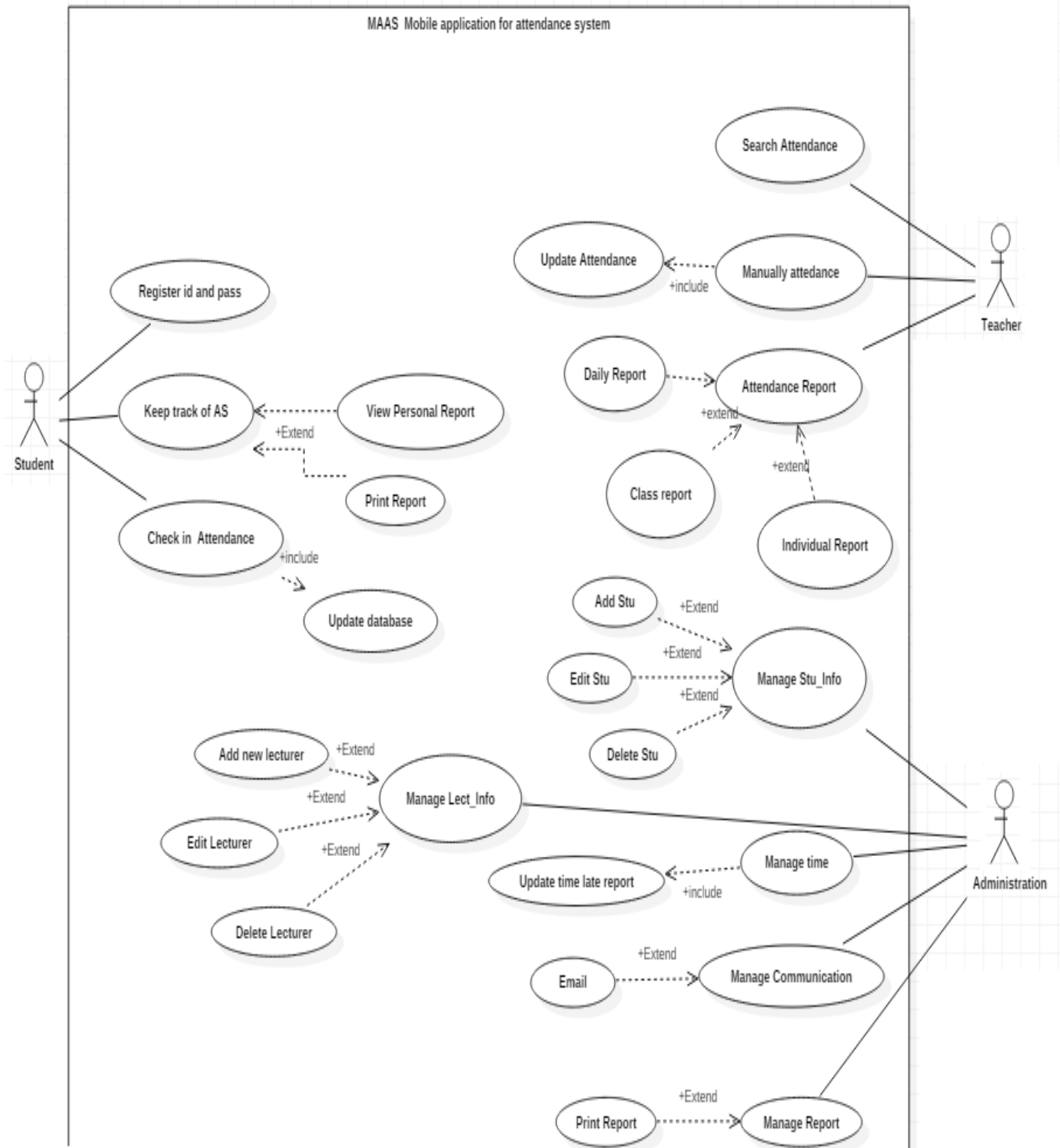

Figure 3.1.1. Use Case Diagram for MAAS

## 3.2. Fully Dressed Use Cases

### 3.2.1. Use Case Diagram for Student

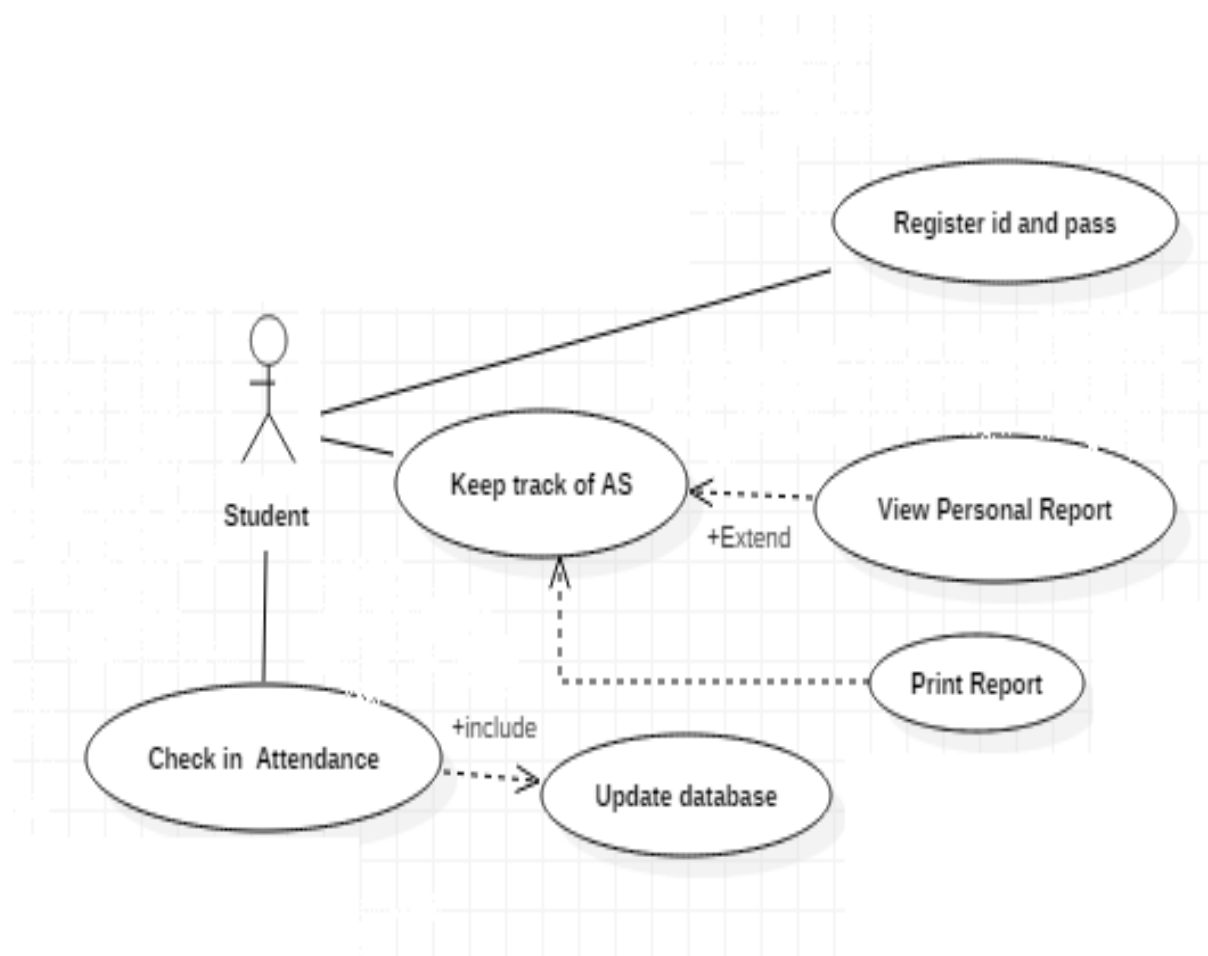

Figure 3.2.1. Use Case Diagram for Student

### 3.2.2. Use Case Diagram for Administrator

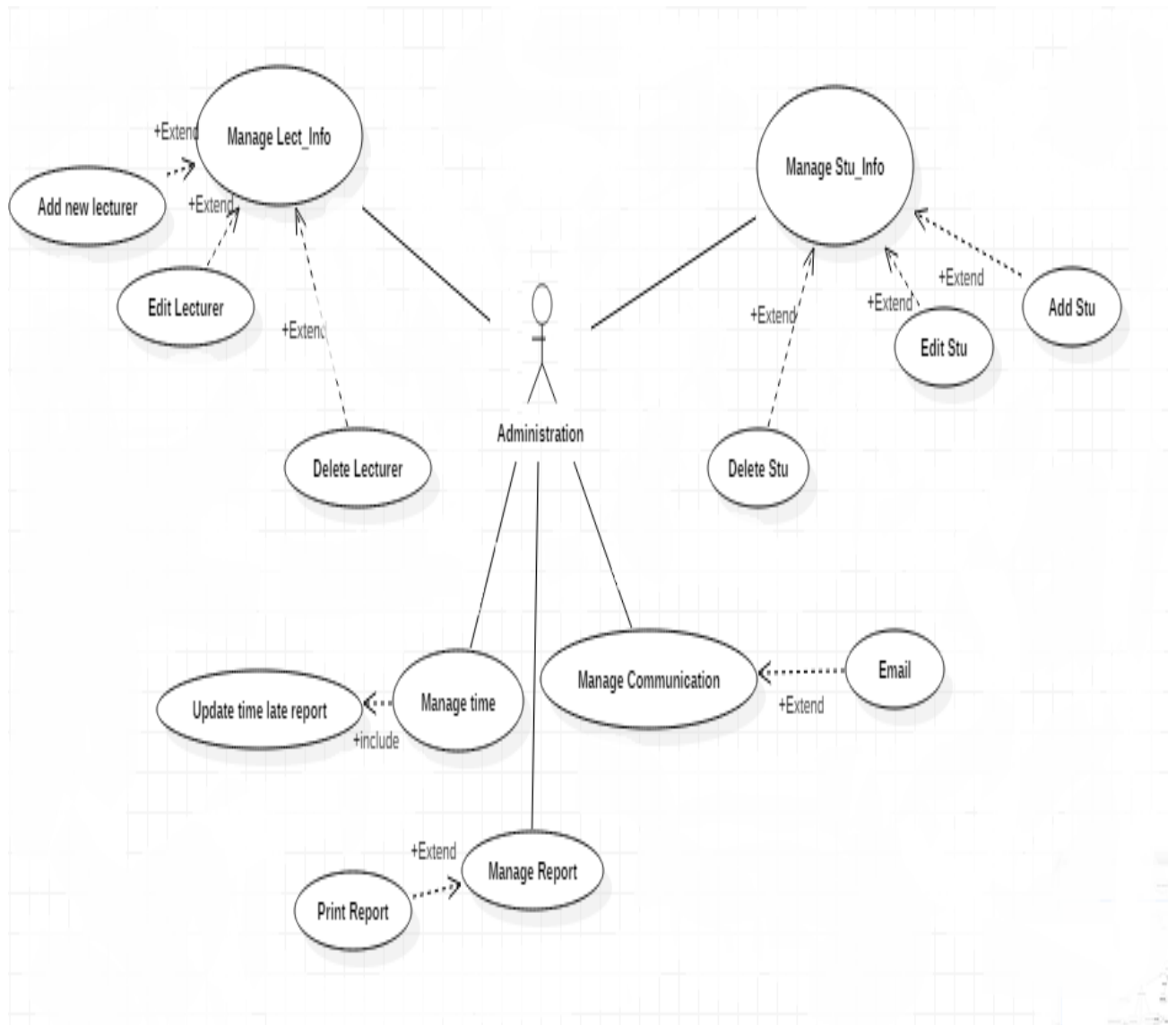

Figure 3.2.2. Use Case Diagram for Administration

### 3.2.3. Use Case Diagram for Teacher

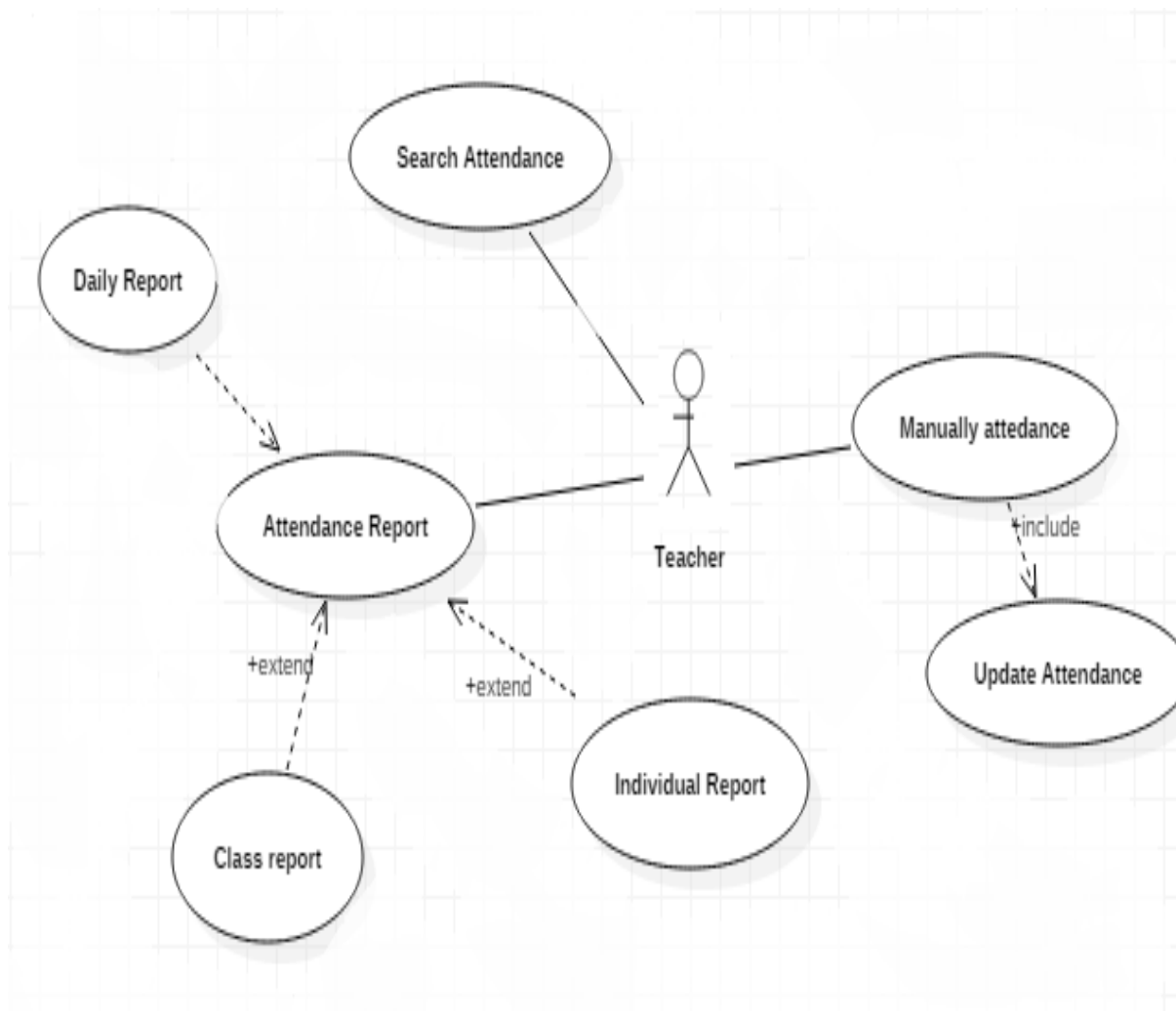

Figure 3.2.3. Use Case Diagram for teacher

Table 3.2.1 Keep Track of Personal Attendance Record Use-Case Description

<b>Use-Case Description</b>		
Use Case Name: Keep Track of Personal Attendance Record	ID: 1	Important Level: High
Primary Actor: Student	Use Case Type: Essential, Detail	
<p>Student – wants to keep track of his/her own attendance record.</p> <p><b>Brief Description:</b> This use case describes how student keep track on his/her personal attendance record by print out report.</p> <p><b>Relationships:</b> Extend: View Personal Attendance Report, Print Report.</p> <p><b>Normal Flow of Events:</b></p> <ol style="list-style-type: none"> <li>1. The student wants to keep track of his/her own attendance record.</li> <li>2. The student request to login.</li> <li>3. The system navigates to login activity.</li> <li>4. The student enters ID &amp; password to the system.</li> <li>5. The system validates the student ID &amp; password from database.</li> <li>6. The student request to view his/her own personal attendance report.</li> <li>7. The system displays the personal attendance report.</li> <li>8. The student analyzes the report.</li> <li>9. If print out the report</li> <li>10. The report printed out.</li> <li>11. The system end.</li> <li>12. Else</li> <li>13. The system end.</li> </ol>		

Table 3.2.2. Check-in Attendance Use-Case Description

Use Case Name: Check-in Attendance	ID: 2	Important Level: High
Primary Actor: Student	Use Case Type: Essential, Detail	
Student – wants to check in his/her attendance status.		
Brief Description:		
This use case describes how student handle the process of check-in his/her attendance.		
Relationships:		
Association: Student.		
Include: Update Database.		
Normal Flow of Events:		
<ol style="list-style-type: none"> <li>1. The student wants to check in his/her attendance status.</li> <li>2. The student attends the class.</li> <li>3. The student verifies his/her attendance</li> <li>4. The system matching student name.</li> <li>5. If name and id matched</li> <li>6.The student attendance status updated.</li> <li>7.The system email transaction result to student.</li> <li>8.The system end.</li> <li>9. Else</li> <li>10. The system end.</li> </ol>		

Table 3.3.3. Check-in Attendance Use-Case Description

Use Case Name: Manage Student Information	ID: 3	Important Level: High
Primary Actor: Admin	Use Case Type: Essential, Detail	
<p>Admin – wants to manage the student information in system.</p> <p><b>Brief Description:</b></p> <p>This use case describes how admin handle the process of managing student information.</p>		
<p><b>Relationships:</b></p> <p>Association: Admin.</p> <p>Include:</p> <p>Extend: Add New Student Information, Edit Student Information, Delete Student Information.</p> <p>Generalization:</p>		
<p><b>Normal Flow of Events:</b></p> <ol style="list-style-type: none"> <li>1. The admin wants to manage the student information in system.</li> <li>2. The admin request to login.</li> <li>3. The system navigates to login page.</li> <li>4. The admin enters ID &amp; password to the system.</li> <li>5. The system validates the admin ID &amp; password from database.</li> <li>6. The admin select action to be performed.</li> <li>7. If the admin wants to add new student information</li> <li>8. The S – 1: Add new student info performed.</li> <li>9. If the admin wants to edit existing student information</li> <li>10. The S – 2: Edit student info performed.</li> <li>11. If the admin wants to delete existing student information</li> <li>12. The S – 3: Delete student info performed.</li> <li>13. The system displays the result.</li> <li>14. The system end.</li> </ol> <p><b>Sub Flows:</b></p> <p>S – 1: Add new student info</p> <ol style="list-style-type: none"> <li>1. The admin enter required information into the system.</li> <li>2. The admin saves the record into the system.</li> </ol>		

Table 3.2.4. Manage Time Late Policy controlled by Admin Use-Case Description

Use Case Name: Manage Lecturer Information	ID: 4	Important Level: High
Primary Actor: Admin	Use Case Type: Essential, Detail	
<p>Admin – wants to manage the lecturer information in system.</p> <p><b>Brief Description:</b></p> <p>This use case describes how admin handle the process of managing lecturer information.</p> <hr/> <p><b>Association:</b> Admin.</p> <p><b>Include:</b></p> <p><b>Extend:</b> Add New Lecturer Information, Edit Lecturer Information, Delete Lecturer</p> <p><b>Normal Flow of Events:</b></p> <ol style="list-style-type: none"> <li>1. The admin wants to manage the lecturer information in system.</li> <li>2. The admin request to login.</li> <li>3. The system navigates to login page.</li> <li>4. The admin enters ID &amp; password to the system.</li> <li>5. The system validates the admin ID &amp; password from database.</li> <li>6. The admin select action to be performed.</li> <li>7. If the admin wants to add new lecturer information</li> <li>8. The S – 1: Add new lecturer info performed.</li> <li>9. If the admin wants to edit existing lecturer information</li> <li>10. The S – 2: Edit lecturer info performed.</li> <li>11. If the admin wants to delete existing lecturer information</li> <li>12. The S – 3: Delete lecturer info performed.</li> <li>13. The system displays the result.</li> <li>14. The system end.</li> </ol>		

Table 3.2.5. Manage Communication Methods of Admin Use-Case Description

Use Case Name: Manage Communication Methods	ID: 5	Important Level: High
Primary Actor: Admin	Use Case Type: Essential, Detail	
<p>Stakeholders and Interests: Admin – wants to manage the methods to contact/mail the student/parent.</p> <p>Brief Description: This use case describes how admin handle the process of email or SMS to the student/parent.</p> <p>Relationships: Association: Admin.</p> <p>Include:</p> <p>Extend: Email,</p> <p>Normal Flow of Events:</p> <ol style="list-style-type: none"> <li>1. The admin wants to manage the methods to contact/mail the student/parent.</li> <li>2. The admin request to login.</li> <li>3. The system navigates to login page.</li> <li>4. The admin enters ID &amp; password to the system.</li> <li>5. The system validates the admin ID &amp; password from database.</li> <li>6. The admin generate email/SMS to parent/student.</li> <li>7. The admin select the forward methods.</li> <li>8. If email method selected</li> <li>9.The system emails the mail to student/parent through email service.</li> <li>10. Else</li> <li>11. The system SMS the message to student/parent through phone service.</li> </ol>		

Table 3.2.6. Search Attendance History Use-Case Description

Use Case Name: Search Attendance History	ID: 6	Important Level: High
Primary Actor: Lecturer	Use Case Type: Essential, Detail	
<p>Lecturer – wants to search history of the student attendance record.</p> <p>Brief Description: This use case describes how lecturer searches the history of student attendance record</p> <p>Relationships:</p> <p>Association: Lecturer.</p> <p>Normal Flow of Events:</p> <ol style="list-style-type: none"> <li>1. The lecturer wants to search history of the student attendance record.</li> <li>2. The lecturer request to login.</li> <li>3. The system navigates to login page.</li> <li>4. The lecturer enters ID &amp; password to the system.</li> <li>5. The system validates the lecturer ID &amp; password from database.</li> <li>6. The lecturer begins searching on attendance history.</li> <li>7. The system navigates to search attendance history page.</li> <li>8. The lecturer enters required searching details.</li> <li>9. The system performs searching.</li> <li>10. The system display result.</li> <li>11. The system end.</li> </ol>		

# Chapter 4

## System Design

## Chapter 4: System Design

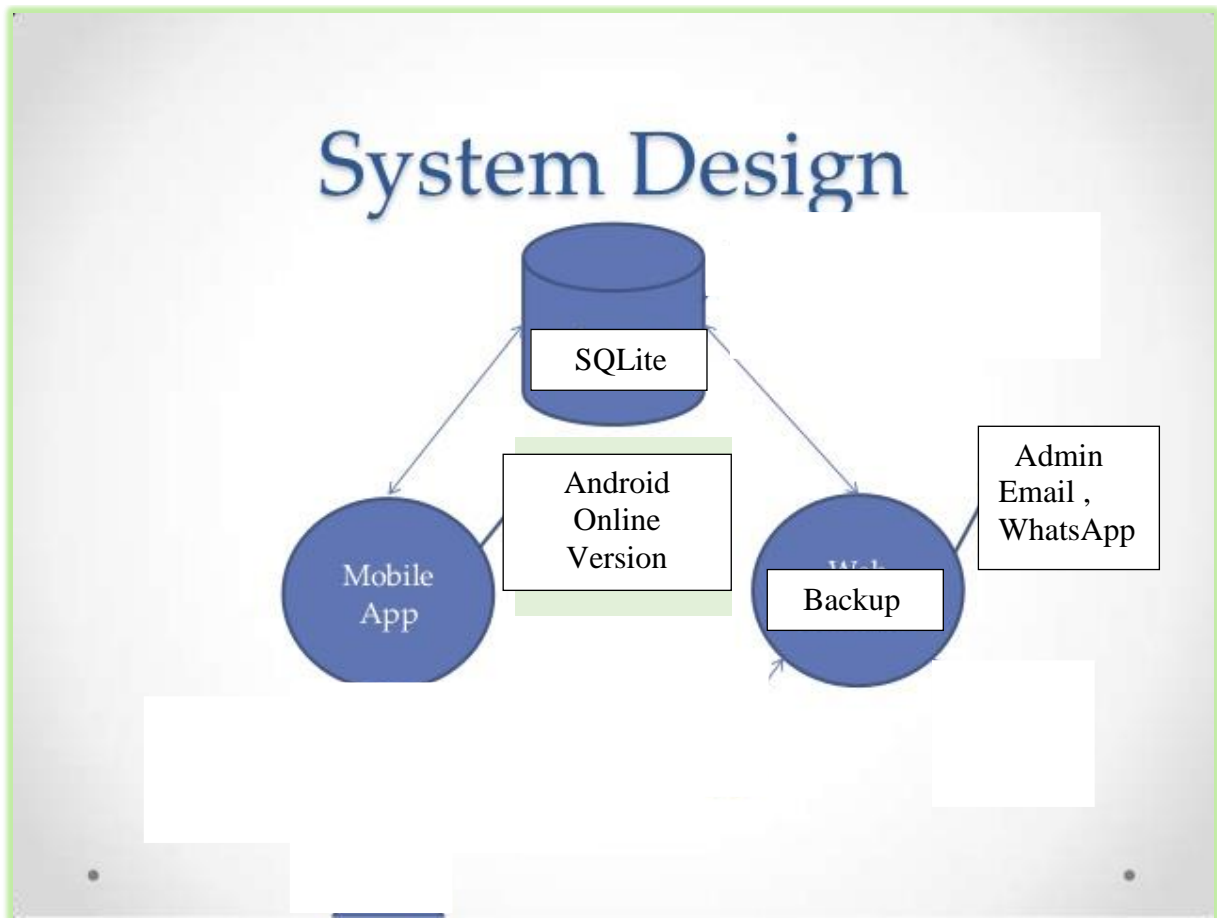

Fig 4.1. MAAS System Diagram

### Description

- System Design of our project MAAS Defines as Mobile application Sends data to Server as online based sending phase to send reports to upload relative google drive mail id.
- For the purpose of designing the database we used SQLite Database.

## 4.1. Architecture Diagram



Fig 4.1 F2 MAAS Architectural Diagram

### Description

- Architecture Design of our project MAAS Defines as Mobile application firstly targets online app to send the reports and managerial data against student's attendance record as well as weekly monthly and yearly report generation by sending on the bases of internet to database.
- Administration are able to View data on their Desktop send .by MAAS.
- Parents are easily view attendance records on daily bases by WhatsApp.
- Now Teachers are able to easily manage attendance record and update students result by MAAS app.

### 4.2. Entity Relationship Diagram with data dictionary

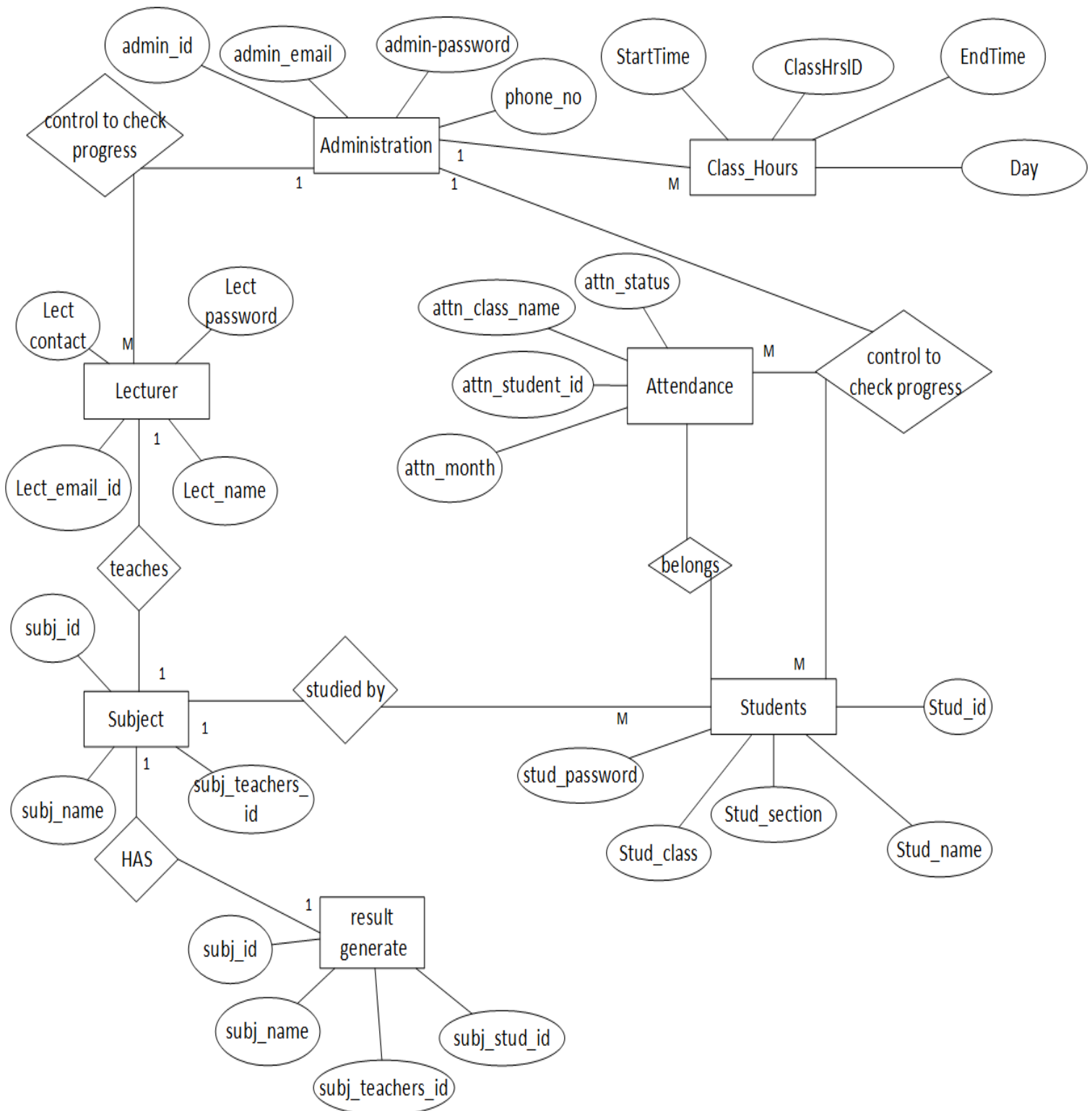
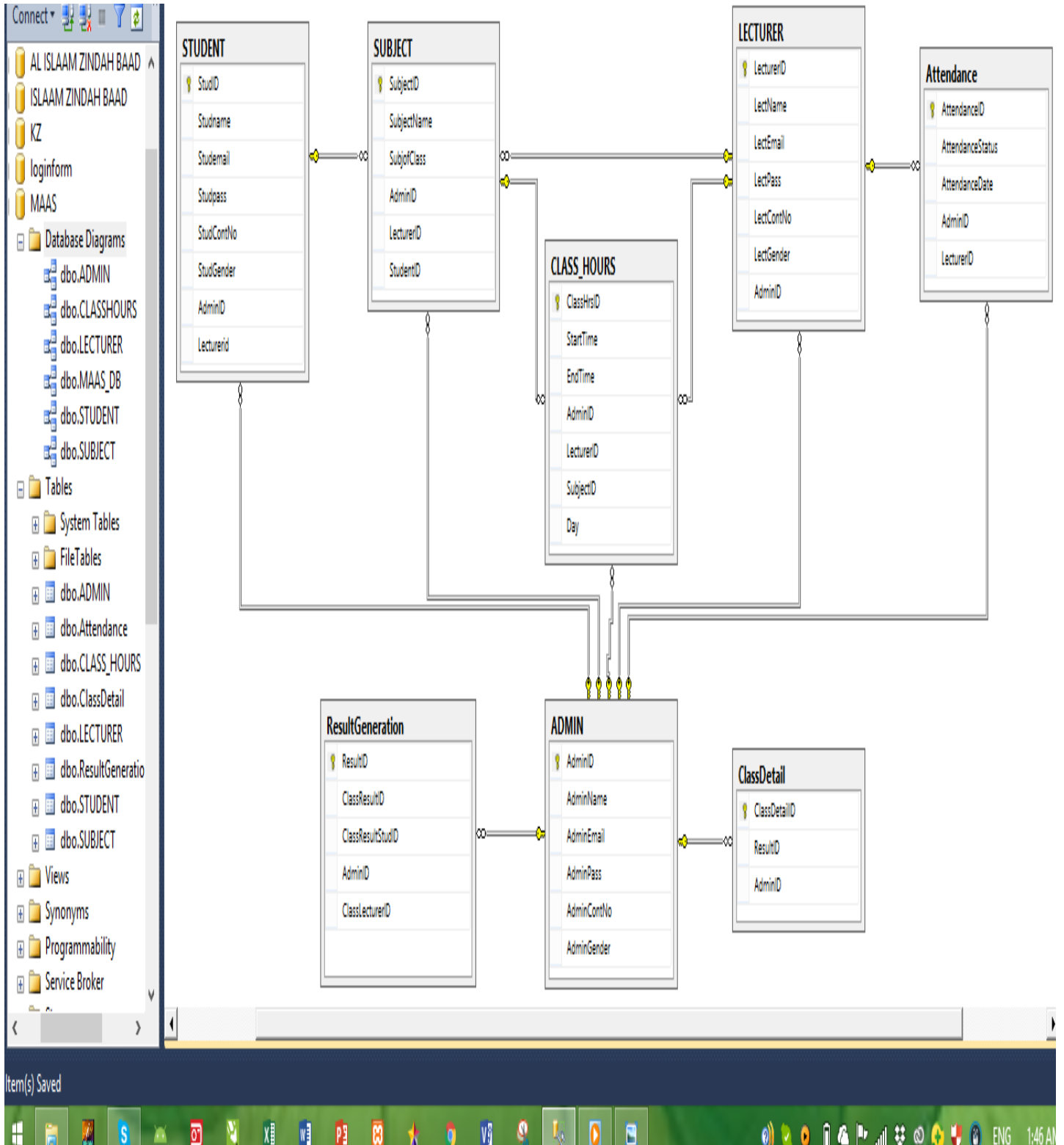

Figure 4.2.1 MAAS ERD Diagram

**Database of MAAS.**



**Figure 4.2.1.1 MAAS DB Diagram**

### 4.2.1 Data Dictionary

#### Student Entity

Table 4.3.1. Table of Student Entity

<i>Entity Name</i>	Attributes	Description	Data Type	Null
<i>Student</i>	studentID	Unique identifier for student	varchar(50)	No
	studentName	Name of student	varchar(50)	Yes
	studentPass	Password of student	varchar(50)	Yes
	studentContNo	Contact no. of student	INTEGER	Yes
	studentEmail	Email of student	varchar(50)	Yes
	studentGender	Gender of student	varchar(50)	Yes

#### Lecturer Entity

Table 4.3.2. Table of Lecturer Entity

<i>Entity Name</i>	Attributes	Description	Data Type	Null
<i>Lecturer</i>	lecturerID	Unique identifier for lecturer	varchar(50)	No
	lecName	Name of lecturer	varchar(50)	Yes
	lecPass	Password of lecturer	varchar(50)	Yes
	lecTelNo	Contact no. of lecturer	varchar(50)	Yes
	lecEmail	Email of lecturer	varchar(50)	Yes
	lecGender	Gender of lecturer	varchar(50)	Yes

#### Subject Entity

Table 4.3.3. Table of Subject Entity

<i>Entity Name</i>	Attributes	Description	Data Type	Null
<i>Subject</i>	subCode	Unique identifier for subject	varchar(50)	No
	subName	Name of subject	varchar(50)	Yes

*Attendance Entity*

Table 4.3.5: Table of Attendance

<i>Entity Name</i>	Attributes	Description	Data Type	Null
<i>Attendance</i>	attendanceID	Unique identifier for attendance	varchar(50)	No
	attendanceStatus	Status of attendance	varchar(50)	Yes
	attendanceDate	Date of attendance	date	Yes
	stuClassID	Identifier for student's class	varchar(50)	No

*ClassDetail Entity*

Table 4.3.8. Table of Class\_DetailEntity

<i>Entity Name</i>	Attributes	Description	Data Type	Null
<i>Stu_Class</i>	stuClassID	Unique identifier for student and class enroll	varchar(50)	No
	studentID	Identifier for student	varchar(50)	No
	classDetailsID	Identifier for class	varchar(50)	No

### 4.3. Activity Diagram

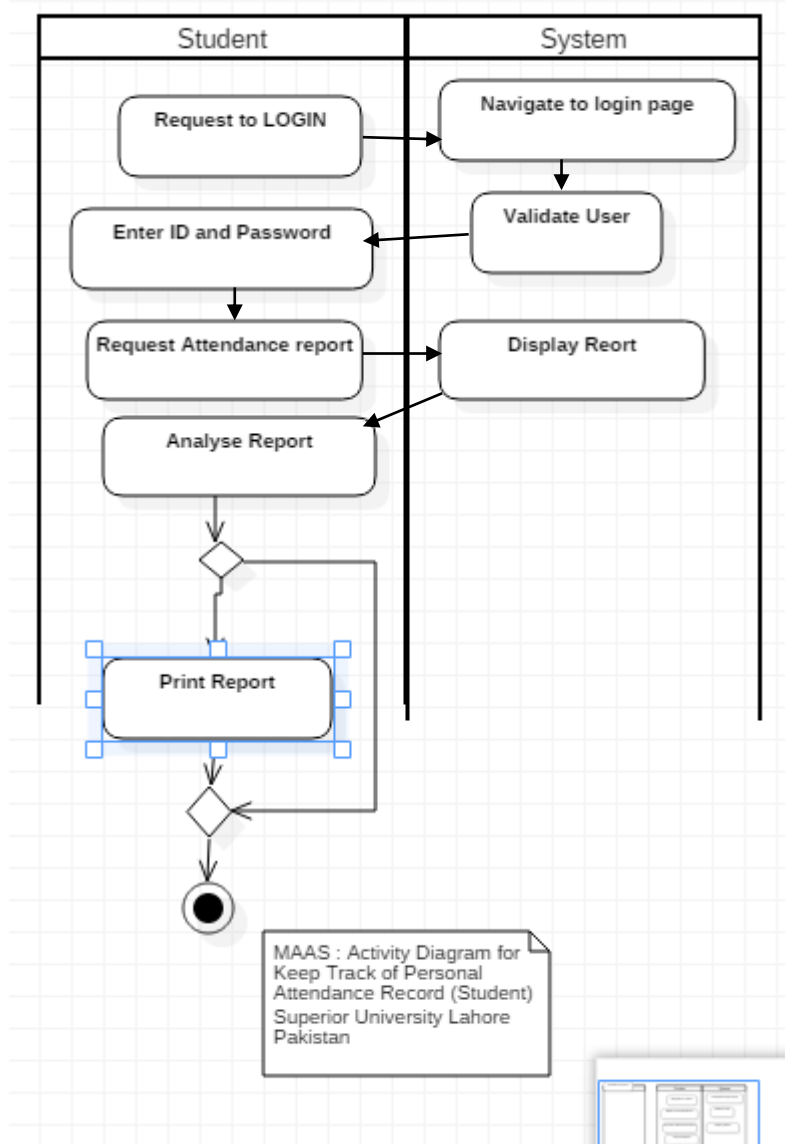

Figure 4.3.1. Activity Diagram for keep track of personal Attendance Record

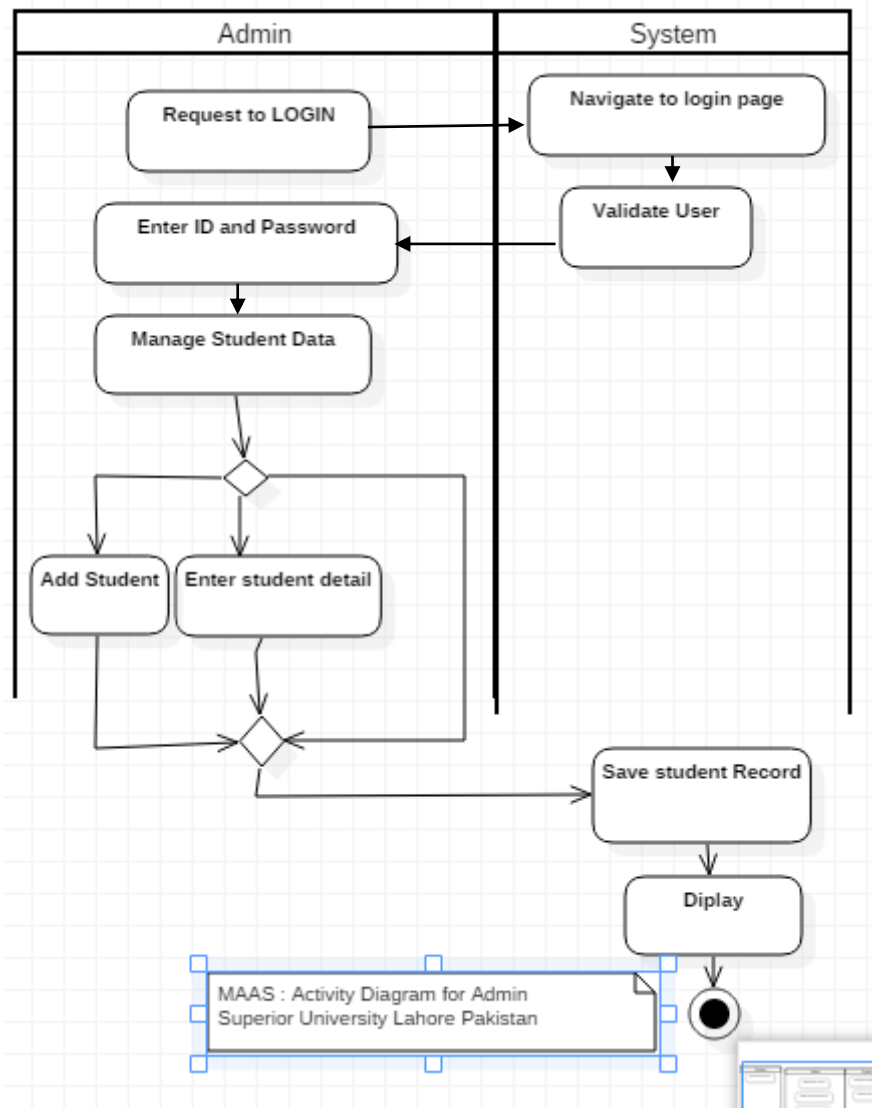

Figure 4.3.2 Activity Diagram for Admin

### 4.4. Sequence Diagram

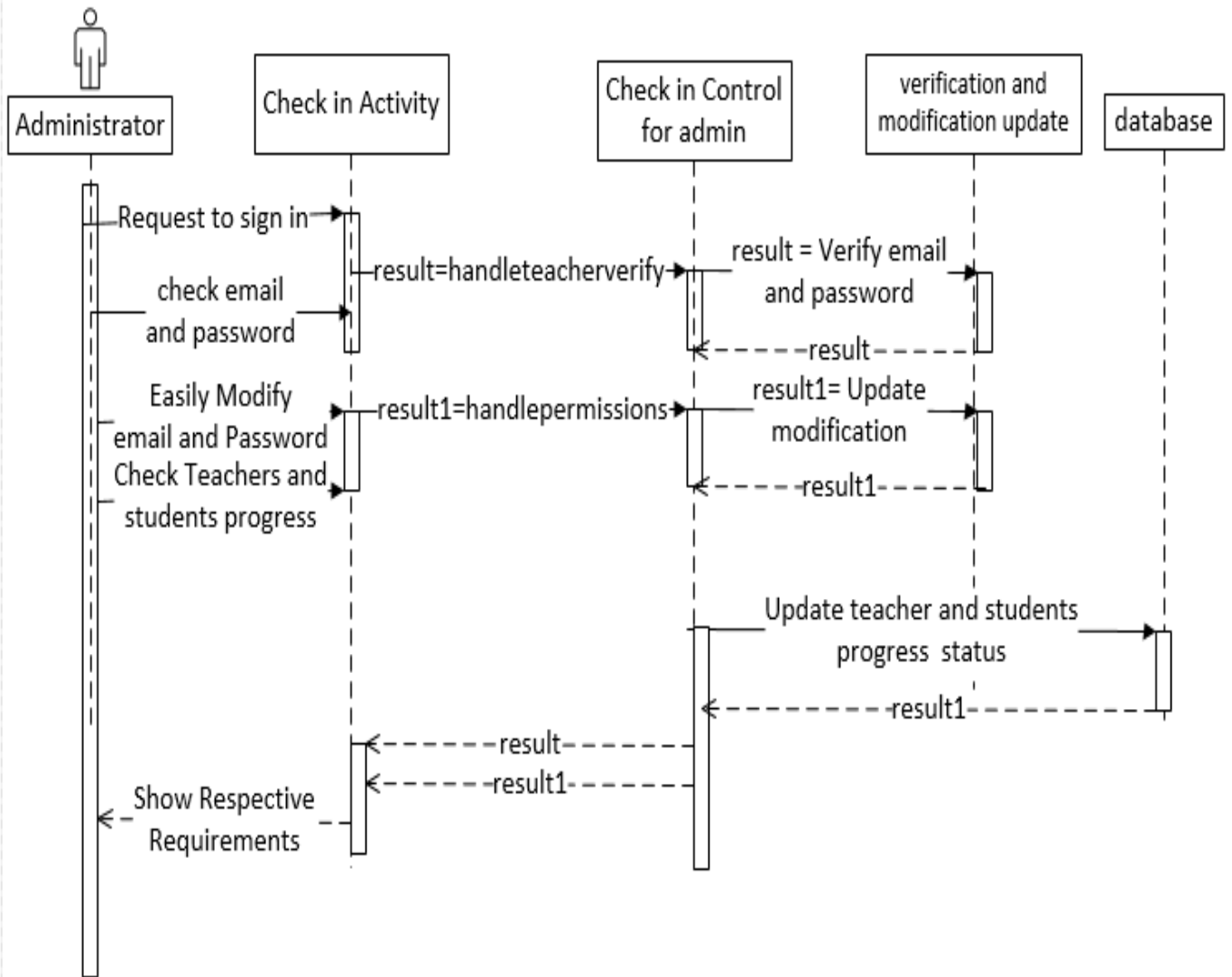

Figure 4.4.1. Sequence Diagram for students Administration Control

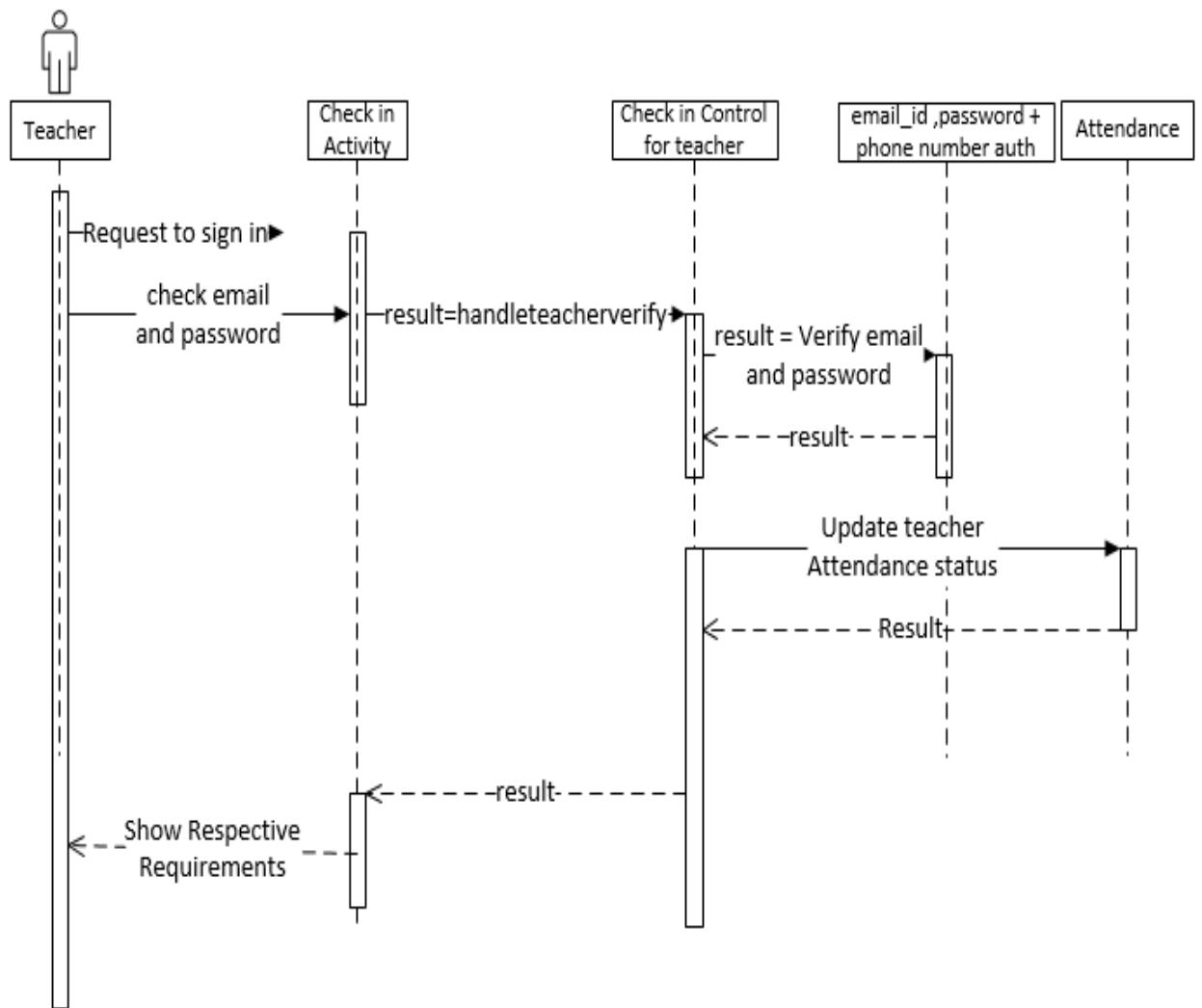

Figure 4.4.2. Sequence Diagram for Teachers CheckinAttendance

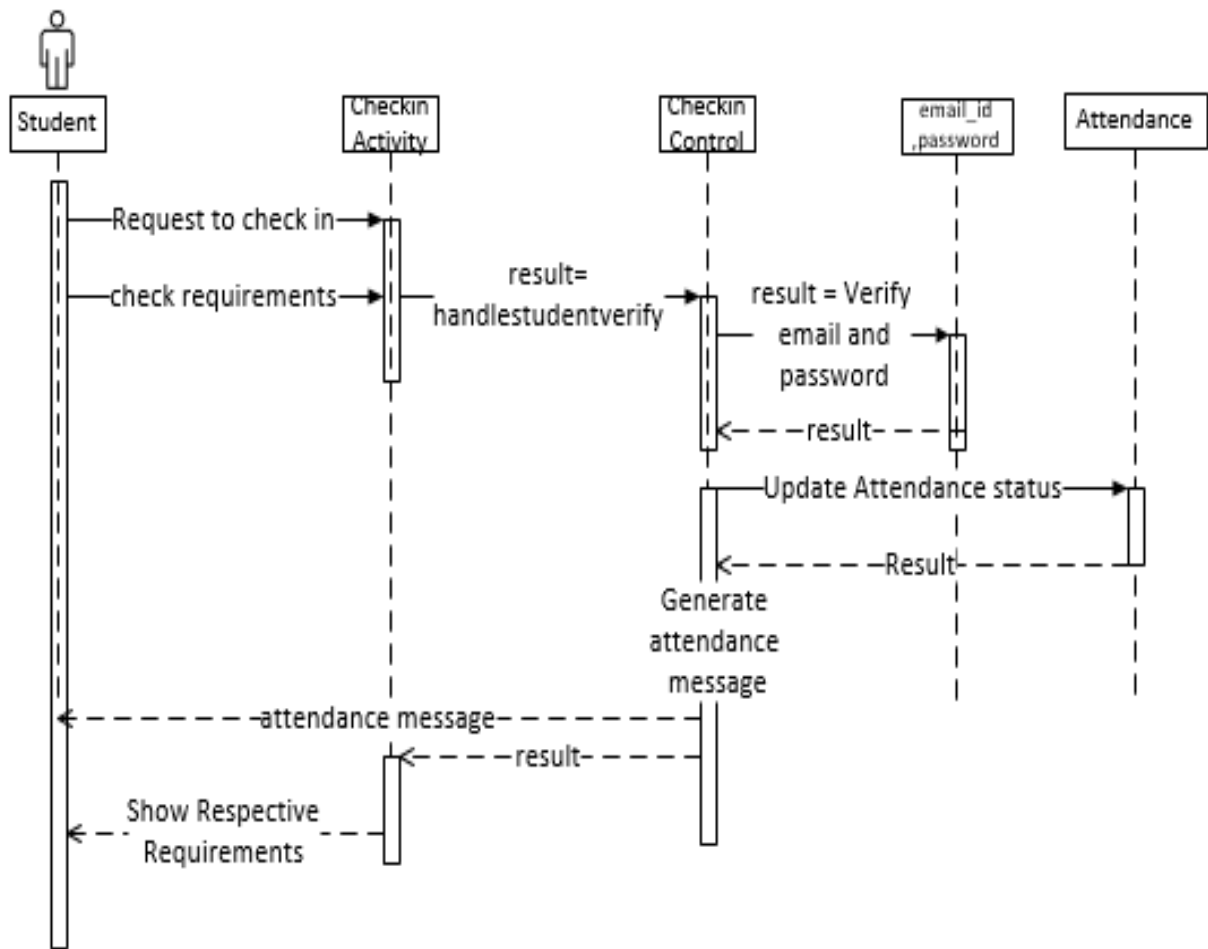

Figure 4.4.3. Sequence Diagram for Students CheckinAttendance

#### 4.5. Component Diagram

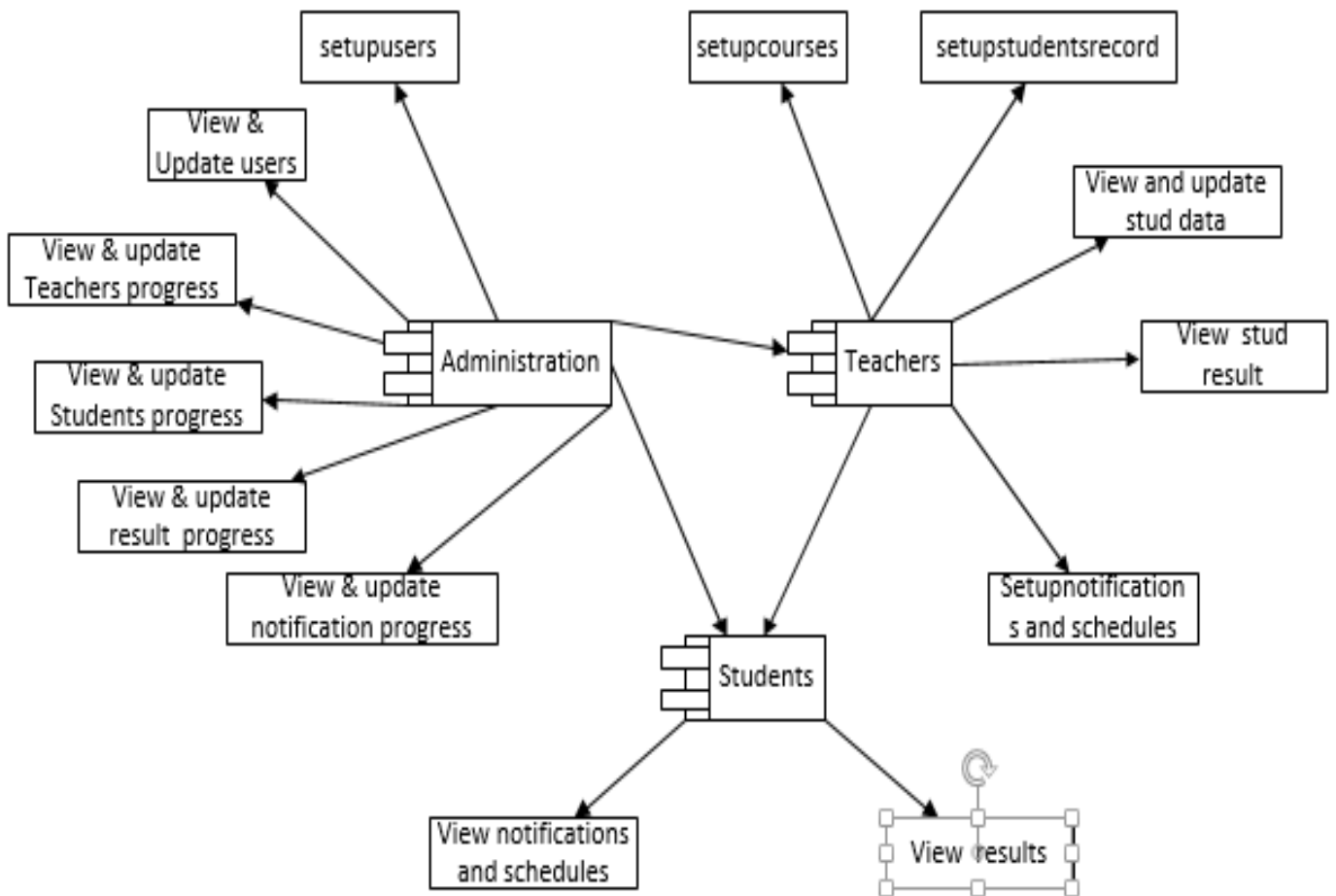

Figure 4.5. Component Diagram for MAAS

### 4.6. Class Diagram

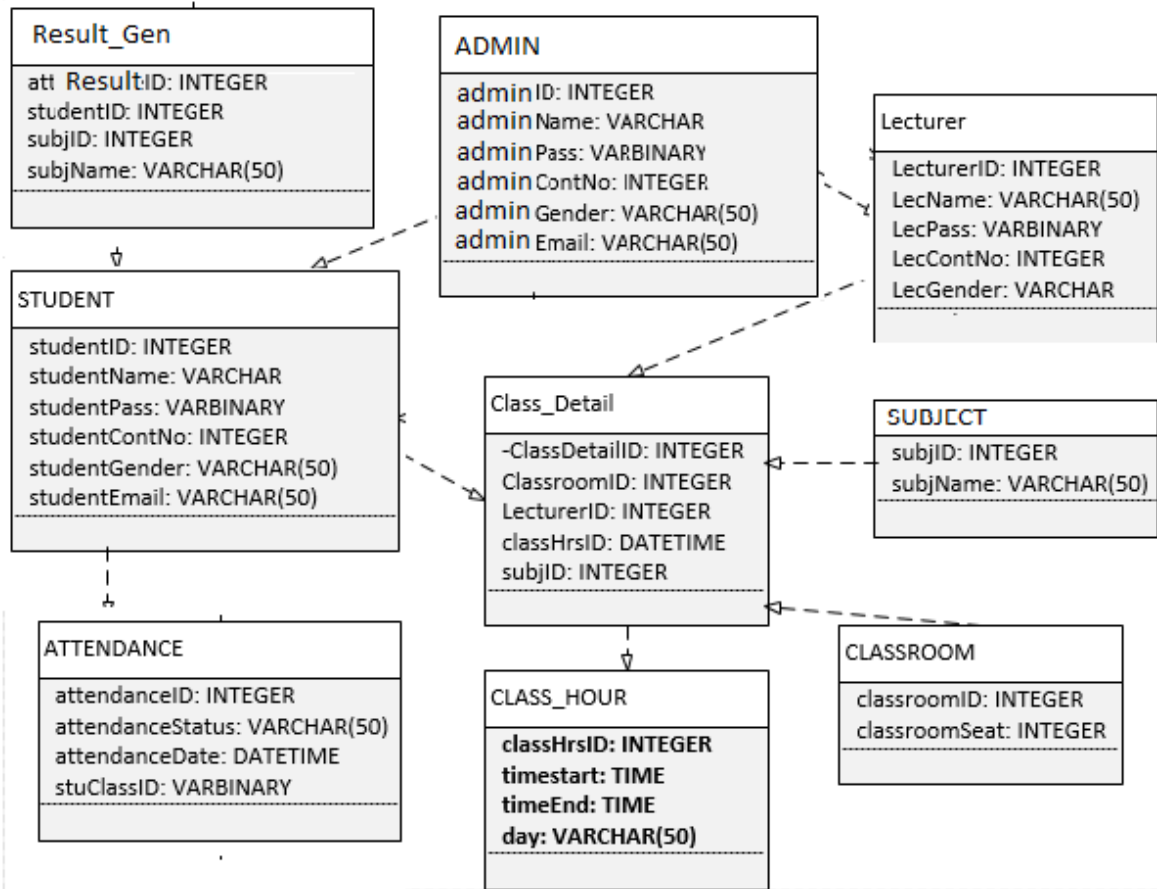

Figure 4.6. Class Diagram for MAAS

### 4.7. DFD Level 0 Context Diagram

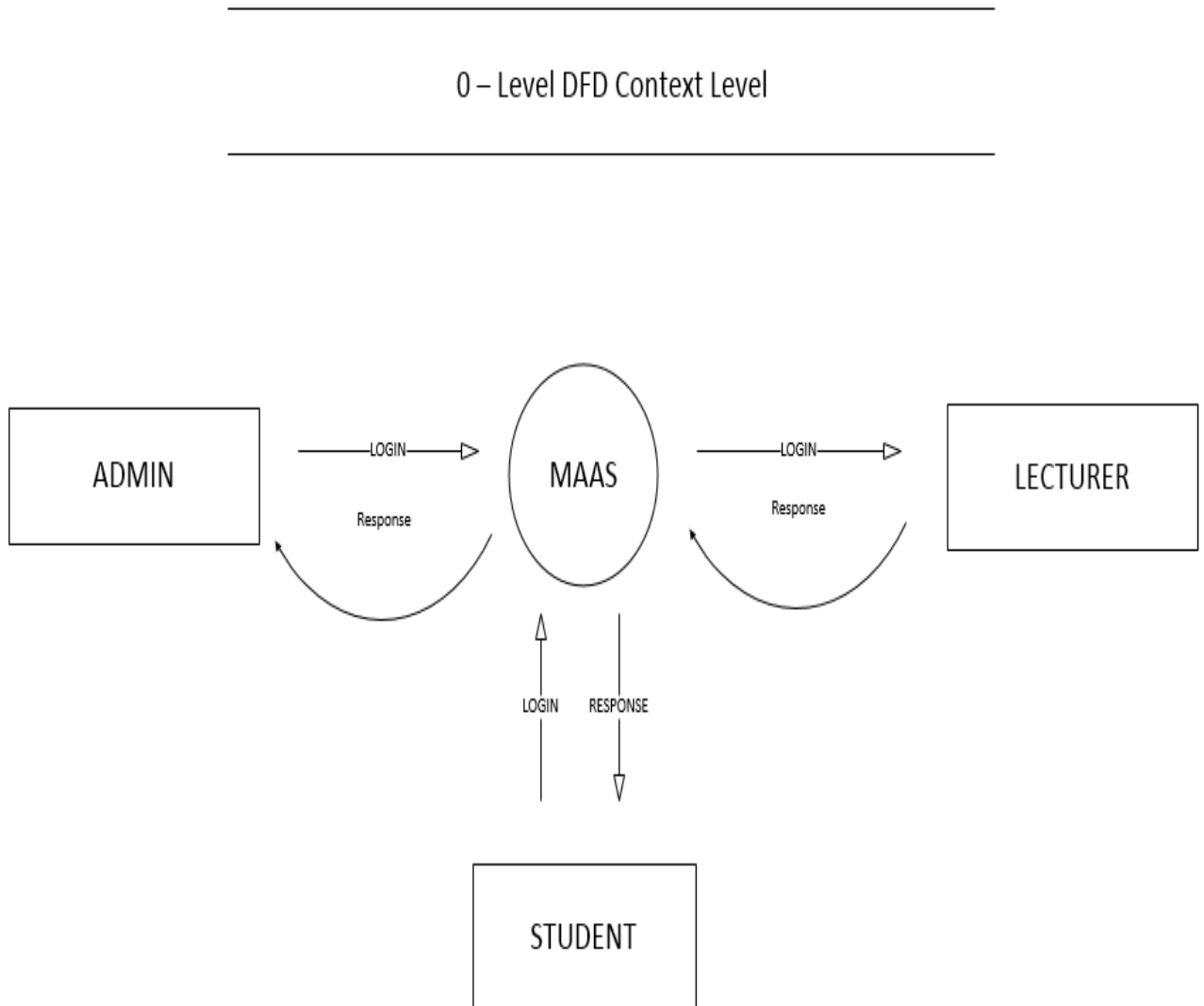

Figure 4.7.1. Level 0 Context Diagram

# Chapter 5

## Implementation

## Chapter 5: Implementation

System implementation and deployment is the part in which the system is implemented and deployed into real life to be used. The system can only be implemented and deployed when the system design and analysis is completed.

### 5.1. Important Flow Control/Pseudo codes

#### Manage Lecturer Information

Edit the latest lecturer details into the system if there are any changes. The lecturer data already exist in the system. The lecturer profile is updated into LECTURER table. Delete the lecturer details from the system. The lecturer data already exist in the system. The lecturer profile is deleted from the LECTURER table.

#### Add Class Period

Add the new class period into system. The CLASS\_DETAILS must be created first before the CLASS\_HOUR. The CLASS\_HOUR profile is added into CLASS\_HOUR table.

#### Update Class Period

Edit the latest classHrs details into the system if there are any changes. The CLASS\_HOUR data already exist in the system. The CLASS\_HOUR profile is updated into CLASS\_HOUR table.

#### Delete Class Period

Delete the classHrs details from the system. The CLASS\_HOUR data already exist in the system. The CLASS\_HOUR profile is deleted from CLASS\_HOUR table.

#### Add Subject

Add the new subject into application. The subject is allowed to teach in the college. The subject profile is added into SUBJECT table.

#### Update Subject

Edit the latest subject details into the system if there are any changes. The subject data already exist in the system. The subject profile is updated into SUBJECT table.

#### Delete Subject

Delete the subject details from the system. The subject data already exist in the system. The subject profile is deleted from the SUBJECT table.

#### Check-in Attendance

Check-in attendance into the system. The student wants to check-in his/her attendance. The attendance status successfully updated into system[5].

## 5.2. Deployment Environment

Before starting to develop the attendance system, the necessarily development tools must be downloaded and installed to the devices used for system development. Therefore, Android Studio 3.0 2017 latest, SQLite, Google Chrome, and etc. was downloaded and installed for system development purpose. The process is be quite time-consuming since every development tools is need to perform the configuration needed during the installation. Although it is quite time-consuming, but this step can be seen as a very important step before the development begins.

After all the development tools installation done, the next thing to do is to configure and create table entity of the database. Based on the system design, the database is be created to be used for later data storage. By using the SQLite, the database can be easily created since developer just need to key in the queries in order to create a new table. Many features are provided by the SQL Server which ease and reduce the burden of developer in creating database.

After the creation of database, the system development is begin with creation of user interfaces using the Android Studio which allows us just drag and drop the control elements (button, label, and etc.) from the toolbox provided by the development tools. Android Studio have offer a good feature for all developers which is separate the user interface code from the behind-code which make it looks more clean and easy for maintenance later during the development

## 5.3. Tools and Techniques

The development tools needed in order to develop this system are includes Android Studio 3.0 2017 latest, SQLite, and etc. Android Studio 3.0 2017 latest, is available for download from the official website of android developer. It provides two different development tools version which one is for non-commercialize development and the other one is for commercialize development. However, the features both versions provided are totally same. Therefore, it is not restrict the development of this system.

Another development tool used in the system development is the SQLite. This development tool mainly purpose is for creating the database to be integrate with the system. In addition, this development tools also can be downloaded for free from the website and without any copyright issues or payment needed.

## Hardware Requirements

The minimum hardware requirement in develop this system are listed as below:

**Table 5.3.1 HR**

Hardware Description	Minimum Requirements
Processor	Intel Core i3 Dell 64 bit
Memory	1 GB RAM Recommended
Hard disk space	Up to 3 GB Recommended

## Software Requirements

The minimum software requirement in develop this system are listed as below:

**Table 5.3-F2 SR**

Software Description	Minimum Requirements
Operating System (OS)	All 32/62-bits Microsoft Windows (7,8,8.1,10)
Browser	Google Chrome (20.0 & above).

## 5.4. Version Control

[MAAS Version 2.2.]

# Chapter 6

## Testing and Evaluation

## 6.1. Use Case Testing

Table 6.2.1. Corresponding Unit Test Case for 'Admin' case:

Test Cases	Steps	Expected Result
A	View Admin List 1	
1	Enter Admin Name	User can enter Admin name
2	Enter Admin ID	User can enter Admin ID
3	Click on login button	Admin successfully Login
<b>B</b>	<b>View Admin Mark List 2-Invalid ID</b>	
1	Repeat steps 1 and 2 of View Admin Mark List 1	
2	Enter AdminID	System displays Error message

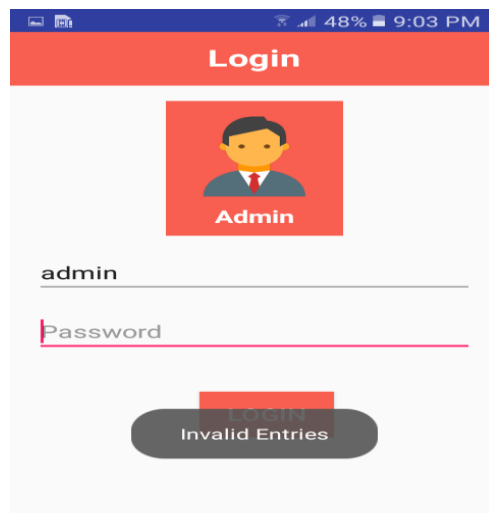

**Table 6.1.2. Corresponding Test Case for ‘Student’ case:**

Test Cases	Steps	Expected Result
A	View Student List 1	
1	Enter Student Name	User can enter Student name
2	Enter Student ID	User can enter Student ID
3	Click on Login	Student Successfully login
<b>B View Student Mark List 2-Invalid ID</b>		
1	Repeat steps 1 and 2 of View Student Mark List 1	
2	Enter Student ID	System displays Error message

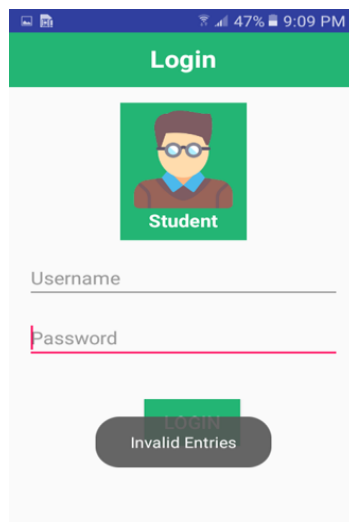
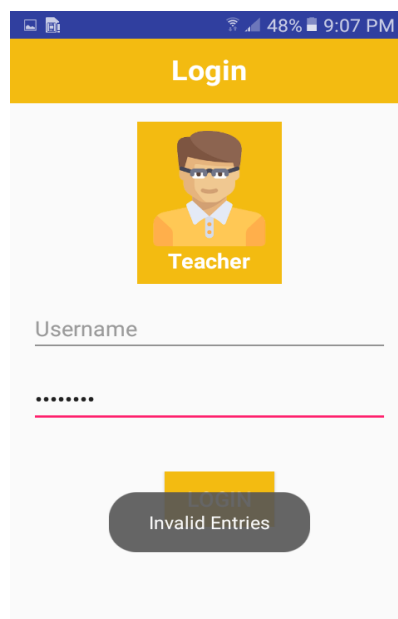

Table 6.1.3. Corresponding Test Case for 'Teacher' case:

Test Cases	Steps	Expected Result
A	View TeacherList 1	
1	Enter TeacherName	User can enter Teachername
2	Enter TeacherID	User can enter TeacherID
3	Click on Login	Student Successfully login
<b>B View TeacherMark List 2-Invalid ID</b>		
1	Repeat steps 1 and 2 of View TeacherList 1	
2	Enter TeacherID	System displays Error message



## 6.2. Equivalence partitioning

## 6.3. Boundary value analysis

School Names: Manually

Sections: Manually

Class Names: Manually

Classes:  $>0 \leq 10$

Time Start: Manually

Time End: Manually

Admin Controls: Teachers and Students Record and Set their boundaries.

Teachers: Controls Attendance and Set marks distribution boundaries of students.

Students: Every Student can view his respective attendance.

## 6.4. Unit testing

**Unit Testing 1:** Login as Users (Admin, Lecturer, Student)

**Testing Objective:** To make sure the login process functioning well.

**Table 6.4.1.: Table of Login as Users (Admin, Lecturer, Student)**

No	Test Case	Attribute and Value	Expected Result	Result
1	Verify the login ID and password entered by users after click on "Login" button with correct data provided.	User ID: admin Password: admin	Login successfully.	Pass
2	Verify the login ID and password entered by users after click on "Login" button with null value.	User ID: Password:	Required Validator validation shown and require users to key-in ID and password.	Pass
3	Verify the login ID and password entered by users after click on "Login" button with Invalid data provided.	User ID: teacher Password: bhjs12@	Login failed. Error message Prompt out showing invalid login.	Pass

**Unit Testing 2:** User Personal Profile.

**Testing Objective:** To make sure data successfully read from sqlite database and display to mobile control. (Admin, Lecturer, Student)

**Table 6.4.2.: Login as Users (Admin, Lecturer, Student)**

No	Test Case	Attribute and Value	Expected Result	Result
1	Display data to mobile control	lectID	Personal details successfully displayed on mobile control.	Pass
2	Direct users to login activity	Navigate to specific activities without login.	Redirect back to login activity.	Pass
3	Retrieve correct details of the users	lectID	Successfully display details of specific Users based.	Pass

**Unit Testing 3:** Edit Personal Profile. (Admin, Lecturer, Student)

**Testing Objective:** To make sure users successfully edit their personal details.  
(Admin, Lecturer, Student)

**Table 6.4.3.: Edit Personal Profile (Admin, Lecturer, Student)**

No	Test Case	Attribute and Value	Expected Result	Result
1	Edit personal details with correct data provided.	Example: Phone No: 03004133085	Personal details successfully edited and saved to database.	Pass
2	Edit personal details with invalid data provided.	Example: Phone No: 016abc4817	Personal details amendment failed And validation message shown.	Pass
3	Edit personal details with null data provided.	Example: Phone No:	Personal details amendment failed and required field validation message shown.	Pass

**Unit Testing 4:** Create User Profile.(Admin)

**Testing Objective:** To create user profile for lecturer and student.

**Table 6.4.4.: Create User Profile (Admin)**

No	Test Case	Attribute and Value	Expected Result	Result
1	Create lecturer profile by insert their email.	Example: Lecturer ID: teacher1 Email: t@gamil.com	Email contains loginID and temporary password sent to lectureremail.	Pass
2	Create student profile by insert their email.	Example: Lecturer ID: student11 Email: <a href="mailto:s@gamil.com">s@gamil.com</a>	Email contains loginID and temporary password sent to studentemail.	Pass

**Unit Testing 5: Create New Classroom.(Admin)****Testing Objective:** To create new classroom details.**Table 6.4.5.: Create New Classroom (Admin)**

No	Test Case	Attribute and Value	Expected Result	Result
1	Create new classroom by insert the capacity.	Section : A Room Number: 1-10	Classroom successfully created and stored into database.	Pass
2	Section is based on last Alphabet stored in the database.	Previous Section : A Current Section :A	Classroom ID automatically generated without duplication.	Pass
3	Auto-refresh the page once classroom created to make sure Section of the classroom refreshed.	Auto-refresh after classroom creation.	Activity auto refresh after every new classroom created.	Pass

**Unit Testing 6: Create Student and Class Enrollment.(Admin)****Testing Objective:** To enroll student to specific class session, subject, and class type.**Table 6.4.6.: Create Student and Class Enrollment (Admin)**

No	Test Case	Attribute and Value	Expected Result	Result
1	Enroll student to specific class with lecturer, class Sect, and etc.	LecturerID: teacher1 LecturerPass:teacher1 Class Type: Lecture Time Start: 09:00:00 Time End: 11:00:00	Student successfully enrolled into a specific class.	Pass
2	Allow admin to view the details of student	Details fill to mobile control on row click.	Details of specific student displayed on mobile control based on the row clicked.	Pass
3	All the mobile control such as Listview bind with correct data read from database.	Subject Name Lecturer Name Stud Lists	All the mobile control display the proper data based on the query statement assigned to them.	Pass

**Unit Testing 7:** Past class details together with student details.(Lecturer)

**Testing Objective:** To view the details of past class together with student enrolled in the class.

**Table 6.4.7.: Class Details with Student Details(Lecturer)**

No	Test Case	Attribute and Value	Expected Result	Result
1	Retrieve data of class.	Subject Name	Successfully display the wanted details to List view selection.	Pass
2	Classify the details of attended student and absent student.	Student Attendance Status: Attended Student Attendance Status:Absent	Successfully classify the student attendance based on their attendance status.	Pass
3	Allow lecturer to edit specific student attendancestatus.	Change absent status of specific student to attended.	Successfully change the attendance status of specific student.	Pass

## 6.5. Data flow testing

Data flow testing is a family of test strategies based on selecting paths through the program's control flow in order to explore sequences of events related to the status of variables or data objects. Dataflow Testing focuses on the points at which variables receive values and the points at which these values are used.

## Advantages of Data Flow Testing:

Data Flow testing helps us to pinpoint any of the following issues:

- A variable that is declared but never used within the program.
- A variable that is used but never declared.
- A variable that is defined multiple times before it is used.
- Deallocating a variable before it is used

## 6.6. Integration testing[6]

### 6.6.1. Test app component integrations

If your app uses components that users do not directly interact with, such as a Service or Content Provider, you should validate that these components behave in a correct way with your app MAAS.

When developing such components, we should get into the habit of writing integration tests in order to validate the component's behavior when your app runs on a device or an emulator.

#### 6.6.1.1. Test MAAS app service

Your integration test should be written as a JUnit 4 test class

Next, create a `ServiceTestRule` instance in your test by using the `@Rule` annotation.

The following example shows how you might implement an integration test for a service. The test method `testWithBoundService` verifies that the app binds successfully to a local service and that the service interface behaves correctly.

You can run integration tests from Android Studio or from the command-line. Make sure to specify `AndroidJUnitRunner` as the default instrumentation runner in your project.

### 6.6.1.2. Test your content provider

If you are implementing a content provider to store and retrieve data or to make data accessible to other apps, you should test your provider to ensure that it doesn't behave in an unexpected way.

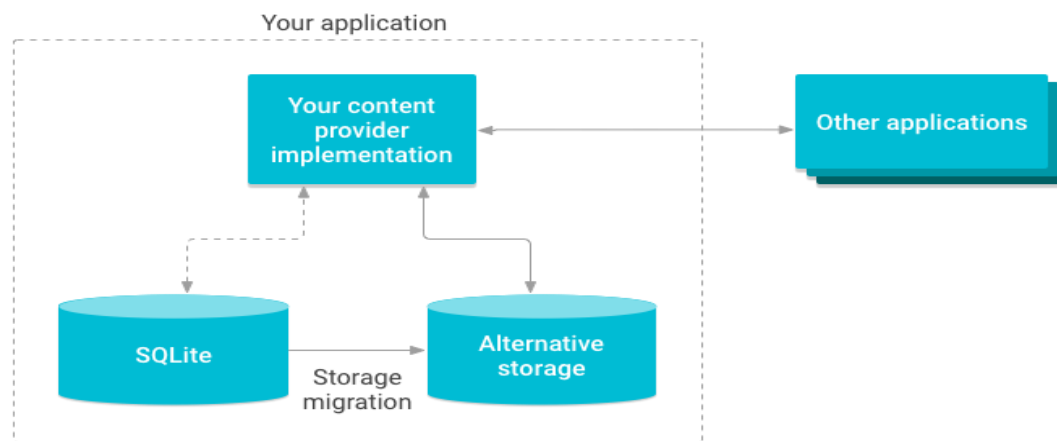

Figure 6.6.1.2.Content Provider

A number of other classes rely on the `ContentProvider` class:

1. `AbstractThreadedSyncAdapter`
2. `CursorAdapter`
3. `CursorLoader`

## 6.7. Performance testing

### 6.7.1.Reduce resource count and size of MAAS

#### Remove unused resources

The lint tool, a static code analyzer included in Android Studio, detects resources in your res/ folder that your code doesn't reference.

Libraries that you add to your code may include unused resources. Gradle can automatically remove resources on your behalf if you enable shrinkResources in your app's build.gradle file.

```
android {  
    buildTypes {  
        release {  
            minifyEnabled true  
            shrinkResources true  
            proguardFiles getDefaultProguardFile('proguard-android.txt'), 'proguard-rules.pro'  
        }  
    }  
}
```

### 6.7.2. Use drawable objects in MAAS

Some images don't require a static image resource; the framework can dynamically draw the image at runtime instead. Drawable objects <shape> in XML can take up a tiny amount of space in your APK. In addition, XML Drawable objects produce monochromatic images compliant with material design guidelines.

### **6.7.3. Reduce Java code**

There are several methods you can use to reduce the size of the Java and native codebase in your app.

Remove unnecessary generated code

Make sure to understand the footprint of any code which is automatically generated. For example, many protocol buffer tools generate an excessive number of methods and classes, which can double or triple the size of your app.

Avoid enumerations

A single enum can add about 1.0 to 1.4 KB of size to app's file. These additions can quickly accumulate for complex systems or shared libraries. ProGuard to strip enumerations out and convert them to integers. This type conversion preserves all of the type safety benefits of enums.

### **6.7.4. Use enhanced for loop syntax in MAAS**

With an ArrayList, a hand-written counted loop is about 3x faster.

Keeping your app responsive

## **6.8. Stress Testing**

Here is a more typical command line, which launch MAAS application and send 500 pseudo-random events to it

```
$ adb shell monkey -p your.package.name -v 500
```

# Chapter 7

## Summary, Conclusion and Future Enhancements

## **Chapter 7: Summary, Conclusion & Future Enhancements**

### **7.1. Project Summary**

This project is about to study and develop a student attendance system that based on mobile-based attendance of student in directive to verify their attendance with mobile application. In this system, mobile application-based attendance system is be developed for a purpose to validate their attendance in all classes. At the same time, mobile application-based attendance system is be developed for admin and lecturer to view and analyze student attendance by produce the attendance report. The main purpose to develop this project is to replace the existing traditional attendance system by provide faster, accurate, and efficient system. With this new mobile-based attendance method, it can remove some problems such as buddy signing, loss of attendance sheet, and control student miss class rate. In developing this project, evolutionary prototyping had been applied as methodology that guides the direction of whole project development. Other than that, system analysis and design technique is used to demonstrate necessary diagrams for purpose to demonstrate the whole system in more clear way. Lastly, the application of this system is absolutely provide more efficient, reliable, and accurate way to accomplish the student attendance data by sharing attendance record to Admin and Parents with google drive and WhatsApp respectively.

### **7.2. Achievements and Improvements**

In evolving this system, some project purposes had been specified. The main purpose of this project is to advance the current existing student attendance system that in use by most of the schools/colleges by develop a mobile application-based student attendance management system. Some objectives of this project had been famous and listed below.

- Now MAAS app is functioned to replace the current existing student attendance system process to fully-mobilized and automated student attendance structure.
- Now MAAS app is functioned to develop a mobile application-based student attendance system in showing every student attendance results efficiently.
- Now MAAS app is functioned To generate reports regarding to the student attendance in order to help the lecturer/staff in examine and tracing the student attendance by sharing attendance record to Admin and Parents with google drive and WhatsApp respectively.

### **7.3. Lessons Learnt**

1. Android application development
2. SQLite database deployment
3. Login controls for Admin
4. How can Admin Controls Teachers and Students credentials?
5. Time Deployment for classes
6. Documentation for Real time Project
7. Testing Phases in android
8. Requirement Analysis for targeted project

### **7.4. Future Enhancements/Recommendations**

1. To eliminate the risks for student to ask their buddy sign attendance for them through the implementation of photo comment in attendance system.
2. Firstly Deploy this system in nearest school of our university then targets all schools of Lahore.

3. The MAAS Student Attendance Management System is only developed for the use of single faculty. In future, it is assumed that this system is to be enhanced to be used by all faculties in a university, school, or college.
4. Other than that, the system developed is more focus on admin role as well as lecturer role which result in fewer features provided to the student role. Student only allowed viewing if they had been barred from certain class.
5. Other than that, the report generated is only be in the excel format. There is no other available option for lecturer to generate the report. Besides that, the system developed only can be used on mobile based but laptop is not recommended for this system.
6. Last but not least, MAAS Student Attendance Management System is still have a lot to improve in order to meet every roles requirement. However, current version is good enough to be implemented to the real life to be used

# Reference and Bibliography

# References

- [1] M. D., "<http://intuitiveedesign.wordpress.com/2011/06/05/review-of-literature-for-improving-attendance-in-secondary-schools/>," 2018. [Online]. [Accessed 17 December 2018].
- [2] D. Marvia, "<http://intuitiveedesign.wordpress.com/2011/06/05/review-of-literature-for-improving-attendance-in-secondary-schools/>," [www.intuitiveedesign.wordpress.com](http://www.intuitiveedesign.wordpress.com/), 1 January 2018. [Online]. Available: [http://intuitiveedesign.wordpress.com](http://intuitiveedesign.wordpress.com/). [Accessed 1 January 2018].
- [3] F. e. a. Ivanilson, "[https://www.academia.edu/4079035/Developing\\_an\\_automatic\\_attendance\\_register\\_system/](https://www.academia.edu/4079035/Developing_an_automatic_attendance_register_system/)," [www.academia.edu](http://www.academia.edu/), 4 January 2018. [Online]. Available: [https://www.academia.edu](https://www.academia.edu/). [Accessed 4 January 2018].
- [4] M. Hasnieza, "[http://library.utem.edu.my/index2.php?option=com\\_docman&task=doc\\_view&gid=3756&Itemid=113](http://library.utem.edu.my/index2.php?option=com_docman&task=doc_view&gid=3756&Itemid=113)," [library.utem.edu.my](http://library.utem.edu.my/), 10 January 2018. [Online]. Available: [www.library.utem.edu.my](http://www.library.utem.edu.my/). [Accessed 10 January 2018].
- [5] C. Nanmal, "<https://www.scribd.com/doc/160477252/srs-for-attendance-management-system/>," [www.scribd.com](http://www.scribd.com/), 17 March 2018. [Online]. Available: [https://www.scribd.com](https://www.scribd.com/). [Accessed 17 March 2018].
- [6] summit, "[developer.android.com](http://developer.android.com/)," Android Developer, 27 08 2018. [Online]. Available: <https://developer.android.com/topic/performance/reduce-apk-size>. [Accessed 27 August 2018].