

Design and Development of a Smart Patient Health Monitoring System for COVID-19 Diagnosis



B.Sc. ELECTRICAL ENGINEERING

Saif-Ur-Rehman

BEEM-F19-014

Muhammad zayyad Abbasi

BEEM-F18-019

Session: 2019 – 2023

Thesis Supervisor:

Dr. Mustafa Shakir

Thesis Co-Supervisor:

Engineer. Sohaib Aslam

DEPARTMENT OF ELECTRICAL ENGINEERING

SUPERIOR UNIVERSITY

LAHORE, PAKISTAN



Design and Development of a Smart Patient Health Monitoring System for COVID-19 Diagnosis

Submitted to Superior University, Lahore in
Partial fulfillment of the requirements
for the award of a degree of

B.SC ELECTRICAL ENGINEERING

Saif-Ur-Rehman

BEEM-F19-014

Muhammad Zayyad Abbasi

BEEM-F18-019

Session: 2019-23

Supervisor:

Dr. Mustafa Shakir

Co-Supervisor:

Engineer. Sohaib Aslam

DECLARATION

This statement report is an arrangement of our creative study task. Moreover, additions of other peoples are elaborate, every determination is made to empower this clearly, with due reference to the literature, and acknowledgment of combined research and discussions. We also assure you that this work is the output of our research, except was identified by references and free from plagiarism of the work of other people.

Signature:

Saif-Ur-Rehman

Muhammad Zayyad Abbasi

Date:

RESEARCH COMPLETION CERTIFICATE

It is certified that the research work contained in this dissertation titled “ **Design and Development of Smart Patient Health Monitoring System for COVID-19 Diagnosis**” has been investigated and carried out by Saif-ur-Rehman and Muhammad Zayyad Abbasi for the degree of Bachelor of Science in Electrical Engineering.

Dr. Mustafa Shakir

Chairman, Electrical Engineering Department

Dr. Manzoor Ellahi

Thesis Committee Member

Dr. M. Rehan Usman

Thesis Committee Member

Dr. Saif-Ur-Rehman

Thesis Committee Member

ACKNOWLEDGEMENTS

In the name of God, who is most beneficial and most merciful?

We thank Allah Almighty who helps us to obtain our target. We are grateful to our parents, who always motivated us and provided us with the ultimate help, love, and care. We would also want to thank our supervisor Dr. Mustafa Shakir and co-supervisor Engineer. Sohaib Aslam for their support and encourage our motivation to work diligently and intelligently. When addressing the classification problem in this research project, We found them very supportive. Undoubtedly, their constructive remarks on our project require us to think of innovative methods and concepts in the area of the Internet of Things and AI. We also want to express our appreciation to all instructors who were very helpful and offered valuable assistance, support, and guidance.

Thank you,

Saif-Ur-Rehman

Muhammad Zayyad Abbasi

DEDICATION

We dedicate this work to our last prophet Hadhrat Muhammad (peace be upon him), my great hero and messenger of Allah Almighty. One of the most influential people, that humanity has ever witnessed.

List of Acronyms

AI	Artificial Intelligence
AmI	Ambient Intelligence
ANN	Artificial Neural Network
ECG	Electrocardiogram
FIS	Fuzzy Inference System
FRBS	Fuzzy Rule-Based System
GUI	Graphical User Interface
IoT	Internet of Things
MICS	Medical Implant Communication Service
NLP	Natural Language Processing
PHMS	Patient Health Monitoring System
PPG	Photoplethysmography
SARS	Severe Acute Recovery Syndrome Corona virus 2
SDGs	Sustainable Development Goals

Table of Contents

LIST OF TABLES	xii
LIST OF FIGURES	xiii
ABSTRACT	xiv
CHAPTER 01	1
INTRODUCTION	1
1.1 Background of COVID-19	1
1.1.1 Innovative Method for COVID-19 in Pakistan	1
1.1.2 Fuzzy Logic Development	2
1.2 Problem Statement	2
1.3 Objectives	2
1.4 Methodology	2
1.4.1 Health parameter sensors	4
1.4.2 Artificial Intelligence (AI)	4
1.5 Work Division	6
1.6 Conclusion	6
CHAPTER 02	8
BACKGROUND OF PATIENT MONITORING SYSTEM	8
2.1 Literature Review	8
2.1.1 Artificial Intelligence	9
2.1.2 Fuzzy Logic	9
2.1.3 Vital Signs Parameters	10
2.2 Proposed work	12
2.3 Advantages of the proposed system	12
2.4 Conclusion	13
CHAPTER 03	14
SIMULATION & RESULTS	14
3.1 Introduction	14
3.2 Methodology	14
3.3 Main components	15
3.4 Sensors Mathematical calculations	15
3.5 Algorithm Flowchart	16

3.6 Simulation Results	17
3.6.1 Body temperature and SpO ₂ monitoring	18
3.7 Graphical representation of Sensors data	18
3.8 Importing Data from the Cloud	20
3.9 Conclusion	20
CHAPTER 04	21
HARDWARE IMPLEMENTATION	21
4.1 Introduction	21
4.2 Block Diagram	21
4.3 Schematic Diagram	21
4.3 List of Components	22
4.3.1 DS18B20	22
4.3.2 LCD	24
4.3.3 ESP-32	25
4.3.4 Pulse rate and blood oxygen sensor (MAX30102)	26
4.3.5 Vero Board	27
4.4 Development of Prototype	27
4.4.1 Front page	27
4.4.2 Dashboard of the proposed project	28
4.4.3 Hardware implementation	29
4.5 Design Calculation	30
4.5.1 DS18B20	30
4.5.2 MAX30102	31
4.6 Conclusion	31
Chapter 05	33
FUZZY LOGIC FOR RELIABILITY OF COVID-19 PREDICTION	33
5.1 Introduction	33
5.2 Fuzzy Collections/ Sets	33
5.3 Fuzzy Logic System Design	33
5.3.1 Input / Output Variables	33
5.4 Fuzzification and Membership Functions	34
5.4 Fuzzy Control Rules	38
5.5 Defuzzification	41

5.5.1 Mean of maximum method (MOM)	41
5.5.2 Centre of Gravity (COG) method	41
5.6 Conclusion	42
CHAPTER 06	43
BUSINESS DESCRIPTION	43
6.1 Form of Business	43
6.1.1 Team/Organization Structure	43
6.1.2 Vision	43
6.1.3 Mission	43
The mission of the project is to	43
6.1.4 Goals and objectives	44
6.2 Industry and Marketing Analysis	44
6.2.1 Industry Analysis	44
6.2.2 Competitive analysis	45
6.2.3 Purpose	45
6.3 SWOT Analysis	45
6.3.1 Strengths	45
6.3.2 Weaknesses	45
6.3.3 Opportunities	45
6.3.4 Threats	46
6.3.5 Marketing Flow	46
6.4 Marketing Communication	46
6.4.1 Advertising	46
6.4.2 Personal Selling	46
6.4.3 Direct Marketing	47
6.5 Financial Plan	47
6.6 Notes	48
6.6.1 Note-1	48
6.6.2 Note-2	48
6.6.3 Note-3	48
6.6.4 Note-4	49
6.6.5 Note-5	49
6.6.6 Note-6	49

6.6.7 Note-7.....	49
6.7 Conclusion.....	49
CHAPTER 07.....	50
CONCLUSION & FUTURE WORK.....	50
7.1 Conclusion.....	50
7.2 Future Work.....	51
REFERENCES.....	52

LIST OF TABLES

Table 1.1: Work division between group members	6
Table 2.1: Literature review summary	10
Table 2.2: Techniques enhancement using smart patient health monitoring system	12
Table 2.3: Key benefits of the patient monitoring system	13
Table 4.1: List of Equipment's	22
Table 4.2: Specifications of Body Temperature sensor	23
Table 4.3: Properties of 20x4 LCD	24
Table 4.4: Specifications of EP32 Controller	26
Table 5.2: Fuzzy Rules	39
Table 6.1: Initial Budget expenses	47
Table 6.2: Statement of Comprehensive Income	48

LIST OF FIGURES

Figure 1.1: Project block diagram	3
Figure 1.2: Applications of AI in COVID-19	5
Figure 1.3: Fuzzy logic vs Boolean logic	6
Figure 3.1: Flowchart of the procedure of COVID monitoring system using Fuzzy logic	16
Figure 3.2: Implemented circuit diagram in Proteus software	17
Figure 3.3: Interfacing of sensors with updating parameters values	17
Figure 3.4: Body temperature and SpO ₂ interfacing	18
Figure 3.5: Graphical representation of patient's body temperature	19
Figure 3.6: Graphical representation of patient's heart rate	19
Figure 3.7: Graphical representation of patient's blood oxygen level (SpO ₂)	20
Figure 3.8: Real-time data obtained from the interfaced cloud	20
Figure 4.1: Block diagram of hardware	21
Figure 4.2: schematic diagram of the proposed system	22
Figure 4.3: DS18B20 temperature sensor	23
Figure 4.4: LCD Configuration	24
Figure 4.5: ESP32 Controller	25
Figure 4.6: MAX30102 sensor	26
Figure 4.7: Front page of Dashboard	27
Figure 4.8: Dashboard	28
Figure 4.9: Graphical content of vital signs on Dashboard	29
Figure 4.10: Prototype of circuit diagram	29
Figure 4.11: LCD result when no temperature and heart rate/SpO ₂ is measured	30
Figure 4.12: LCD result when a person's temperature and heart rate/SpO ₂ is measured	30
Figure 5.1: Input variables of the proposed systems	34
Figure 5.2: Output variable of the proposed system	34
Figure 5.3: Defining membership function for each variable	36
Figure 5.4: Membership graph of body temperature	37
Figure 5.5: Membership graph of blood saturation level	37
Figure 5.6: Membership graph of heart rate	37
Figure 5.7: Membership graph of COVID risk	38
Figure 5.8: Membership graph of COVID risk with indicating level	38
Figure 5.9: Defining the Fuzzy rules	40
Figure 5.10: Fuzzy inference system	40

ABSTRACT

In the past few years, the world pandemic disease COVID-19 has caused a vast number of deaths and struck the way of living of many people. Fast and early detection of Covid-19 is a very crucial task for the doctor and other health-care community, but it is also critical in preventing the spread of the SARS-CoV-2 virus. In recent years, Wireless technology and AI have grown in popularity to overcome the needs of various industries. Artificial intelligence has controlled the industrial organizations, especially in the areas of observation, high technology, and control systems. The technological advancements in the field of sensors, data acquisition, and artificial intelligence (AI) has given an opportunity for early detection and diagnosis of COVID-19 through vital parameters such as body temperature, heart rate, and blood oxygen level.

Therefore, design and development of a smart patient monitor capable of detecting Covid-19 disease will be done in this project. Here, medical sensors will be used to acquire the vital signs of the patient and the data will be processed on the Arduino micro-controller to display it on HDMI LCD. Moreover, the AI branch, Fuzzy Logic Controller (FLC), will be used to detect Covid-19 symptoms based on the fuzzy rules. The Fuzzy logic technique is used in the algorithm and coding to display the results of the patient's vital signs graphically and accurately. Patient health monitoring system contains the benefits such as; a convenient way of accessing patient data, monitoring the COVID-19 virus in the affected patients in real-time, ability to give high-quality care to the patients. The system will not only detect the COVID-19 symptoms in the affected person but will also show the corresponding graphical results on the smart monitor at real-time.

Key index: Artificial Intelligence (AI), Arduino micro-controller, COVID-19 virus, Fuzzy Logic Controller (FLC).

CHAPTER 01

INTRODUCTION

This chapter describes the background of the Smart Health Patient Monitoring system in terms of scientific research. Moreover, we explain the aims of this thesis and our main participation, infrastructure, and the environment used for this work.

1.1 Background of COVID-19

Good health is very important for the people to live a better life. It contains full fitness of physical, mental, and social well-being and not merely a lack of illness. Presently, the COVID-19 crisis is one of the main worldwide problems identified by the health caring associations. On November 2020, the amount of individuals overall estimated to have been tainted with SARS-COVID-2 virus is more than fifty six million, while the absolute deaths from this virus is greater than one and half million, along these lines demonstrating that COVID-19 cases are spreading in overall world [1]. In Bangladesh, there is an addition of 0.4 million positive COVID-19 cases, while the COVID casualty cost is six thousand as of November 21, 2020 [2]. For very few years, the government of Pakistan has taken hard steps to stop the spread of Covid-19 by implementing a smart and complete lockdown in order to control this pandemic situation as early as possible [3].

1.1.1 Innovative Method for COVID-19 in Pakistan

A high value of COVID-19 was observed across the country which created fear among the people after the removal of the first lockdown. This situation of spreading COVID-19 cases is continuing still now. This worldwide pandemic situation produces a situation in which all the health-care resources such as identification kits, medicine, and basic health-care infrastructures were in short amount throughout the era, along with a negative impact on the social and economic system. So, by keeping these issues in view, one of the most admired and innovative methods to help the public to take care of their health in an easy way is the patient monitoring system. Therefore, the design and development of smart patient monitors will be done. Here, the vital signs of the person will be continuously acquired through the sensors and the real-time sensors data will be processed on an Arduino micro-controller to make it compatible with the display on the LCD.

1.1.2 Fuzzy Logic Development

To transform the conventional patient monitor into a smart monitor the FLC will be used. The FLC will use the vital signs as membership input variables and diagnosis of disease as the output variable. Based on the fuzzy rule engine and membership functions, the fuzzy inference system will detect the presence of the COVID-19 virus in a person. However, to increase the detection accuracy a detailed study will be done on the quality of sensors and their interfacing mechanism. Moreover, the cost will also be considered a key focus area of the project.

1.2 Problem Statement

The COVID-19 pandemic situation has fully exposed the current healthcare infrastructure throughout the world and specifically in underdeveloped countries like Pakistan. The healthcare system in Pakistan is facing several challenges. One of them is the limited number of health professionals and their unjustified distribution therefore, a high value serious condition of COVID-19 patients has been observed. Moreover, the situation becomes highly challenging for screening and monitoring a large number of infected or susceptible individuals. A smart patient monitoring system needs to be developed to acquire the vital parameters of the patient through medical sensors and display them on the HDMI LCD. This vital data will be used by the FLC to identify the presence of the COVID-19 virus in a patient.

1.3 Objectives

As Covid-19 disease has spread all over the world and a large number of people die in a day and most of the patients are in hospitals in ICU situations. So, our goal is to prepare a smart monitoring system based on artificial intelligence and fuzzy logic system. The solution to overcome this issue is to monitor or detect the symptoms of Covid-19 in the person which is done using sensors and a smart monitor.

The solution is not only based on the detection of the disease in the affected person but the system will also be proposed to recommend and also show the corresponding medicine on the smart monitor.

1.4 Methodology

To develop the system the following methodology will be used:

The smart patient health monitoring system will be developed in two phases:

In the first phase, various medical sensors detecting the body temperature of a person, heart rate, and oxygen level in the blood will be used to measure the body’s physiological signs i.e., heart rate, body temperature, and blood oxygen level. The acquired data will be processed and displayed on the LCD. In the second phase, smartness will be brought to the patient monitor by introducing Artificial Intelligence (AI) through Fuzzy Logic for an early prediction of COVID-19.

The system model used for developing the system is as follows:

1. Patient monitoring system
2. Controllers and Fuzzy logic.
3. Development of an Intelligently controlled monitoring system.
4. Development of Artificial Intelligence (AI) through Fuzzy logic, and deep learning for remote access to the proposed system.
5. Testing.

Here is the complete block diagram of the proposed project.

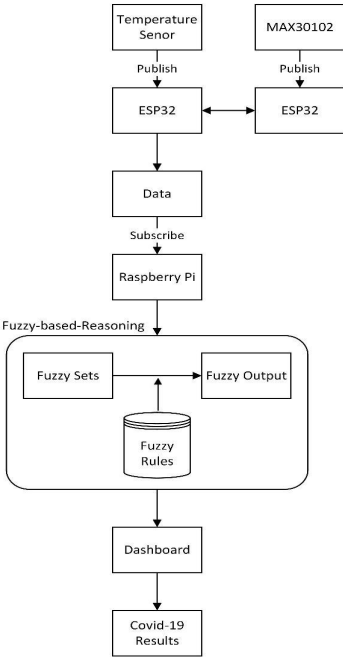

Figure 1.1: Project block diagram

Figure 1.1 shows the block diagram of the patient health surveillance system including health vital sign parameter such as sensors, micro-controller, fuzzy logic, and smart monitor.

1.4.1 Health parameter sensors

1.4.1.1 Body Temperature Sensor (DS18B20)

Body temperature is an essential sign used to measure how well the body produces and releases heat. The DS18B20 is used to measure the degree of hotness of a person's body. The output voltage of the temperature sensor is temperature-dependent. It is a small, inexpensive IC that can determine temperatures between 55 and 150 degrees Celsius. Any ADC or development platform, such as an Arduino micro controller, can easily be interfaced with it [1].

The DS18B20 is an accurately optimized temperature sensor that provides the output voltage, which is linearly proportional to the temperature in degree centigrade ($^{\circ}$ C). The DS18B20 has an advantage over Kelvin's temperature sensors, as a practical centigrade scaling does not allow the consumer to delete the large constant voltage from the display.

1.4.1.2 Pulse-Rate sensor

In the heart cycle, the left sided heart part (ventricles) shrinking causes the blood to flow in the artery, which is the heart rate. Typically, the adults have pulse rates between 60 and 100 beats per minute.

The sensor used to measure the pulse rate is a pulse oximeter (MAX30102), which can be powered by a 1.8V or 2.3V power supply. MAX30102 subsystem consists of the ALC, a 19-bit sigma-delta ADC and a time filter.

1.4.1.3 LCD Display

The Liquid Crystal Display (LCD) module is integrated into the evolved prototype intelligent health monitoring system. The LCD is used to show the values, observations, and results of the vital signs of the patient measured by the sensors.

This Liquid Crystal Display (LCD) is also used to display the saved data of the patients such as and heart patients which are required to be monitored again and again by the doctors and check the previous data of such patients.

1.4.2 Artificial Intelligence (AI)

Artificial intelligence (AI) is the process of technique of intelligence like human, which is controlled by machines, especially computer systems. In today's life, the significant objectives of AI contain

technology-enhanced learning, reasoning, and perception. AI is being utilized today across various industries from finance to healthcare systems.

Weak AI techniques seem to be simple and one-task purposes while strong AI carries on tasks that are more complex, hard, and human-like. In healthcare systems, Natural language processing (NLP) is a type of artificial intelligence technique in computer science that concentrates on assisting the computers to understand the way that humans speak and write. In healthcare systems, artificial intelligence uses NLP applications that can understand and sort medical documentation as shown in Figure 1.2. NLP systems can study unstructured medical notes on patients, giving fabulous insight into understanding quality, improving methods, and a better outcome for patients.

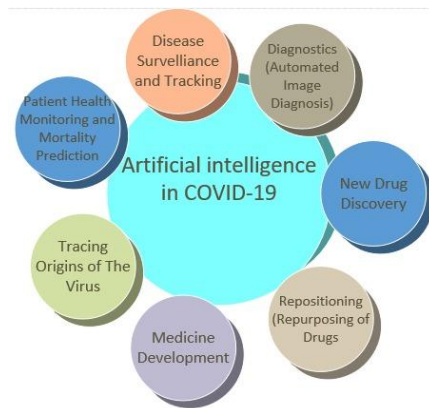

Figure 1.2: Applications of AI in COVID-19

1.4.2.1 Fuzzy logic

The Fuzzy logic is a proper way to give support to the doctors in handling linguistic concepts and get rid of the loss of precised data. Fuzzy logic is applicable in every field of medicine, and this AI technique has been proven to be successful. Fuzzy Logic is similar to how humans perform decision-making. And it involves all intermediate possibilities between YES and NO. Fuzzy logic is the superset of Boolean logic. It tells about the degree of variables. Variables are considered as hot, and cold and the degree of variables includes moderate hot, very hot, and extremely hot and are called membership functions. Similarly, this pattern will repeat for the cold case. The above mentioned scenario is shown in figure 1.3.

In our project, we use this logic for elaborating the intensity of disease i.e., in the case of blood pressure, the degree of blood pressure will be high, very high, moderately high, and low. Similarly for other patients' vital signs.

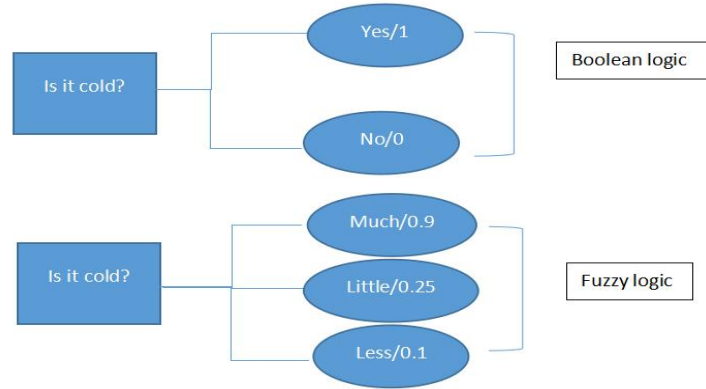

Figure 1.3: Fuzzy logic vs Boolean logic

1.5 Work Division

Table 1.1: Work division between group members

Sr.no	Name	Allocated task
1	Saif-Ur-Rehman	Software logic development and Hardware integrated design.
2	Muhammad Zayyad Abbasi	Software-based simulation, Documentation.

1.6 Conclusion

This chapter describes the development and design of an AI-based medical surveillance system based on human temperature, heart rate, and blood oxygen level for COVID-19 detection. The developed system can also display human body temperature, blood oxygen level, and heart rate on LCD and external source such as laptop, mobile etc., which has been developed so that the patient can get medical care even if the doctor is physically absent. A doctor needs the patient's temperature, oxygen level and heart rate to help a Covid-19 patient for recovery. By utilizing the proposed system, patients can give information to the doctors about their health conditions. Therefore, through an application like mobile and laptop, patients can study the measured oxygen saturation level, pulse rate, and body temperature to avoid severe health conditions. The patient and medical expert can read the data throughout the day by using their application source. This system can also measure

temperature, heart beat, and SpO₂ in real time by showing the results graphically providing us with complete data of the patient's health.

CHAPTER 02

BACKGROUND OF PATIENT MONITORING SYSTEM

2.1 Literature Review

In present years, AI and Wireless technology has become very popular to compete the needs of different industries. Artificial intelligence has played a vital role in controlling the industrial sector, especially in the areas of monitoring, high technology, and control systems. AI technology has brought advancements not only in hospitals but also show impact in personal healthcare services. In presence of smart monitor, various parameters such as heart rate, blood oxygen, and temperature can be monitored. A patient monitoring system consists of devices that are used to monitor and observe a patient's vital signs and generate alerts to healthcare providers if there is an abnormal situation [3].

These systems are required in situations where the patient is in a life-threatening or critical condition or has chronic diseases such as diabetes, high blood pressure, and asthma. [4-5].

Occasional monitoring of diabetic patients is detailed in [6] and monitoring of patients with specific diseases such as Parkinson's disease is also described in [7].

To provide reliable wireless transmission of data, wearable systems have been developed. In [8], the authors developed an IoT-based health caring system to monitor the health state of the patient, and generated alerts will be sent about the patient. In this paper, there was no record keeping of the patient's previous health.

In [9], the authors proposed a patient health monitoring system using IoT with machine learning. The health condition data is collected through the sensors using the IoT framework along with artificial intelligence. The real-time Graphical user interface was missing.

Therefore, based on the deficiencies in the previous works, in this project, a prototype of a smartly controlled AI-based health monitoring system will be developed [10]. This system provides a platform for monitoring the health of patients. The design system consists of various sensors which will be used to monitor the real-time data and all the parameters will be stored in a database for record-keeping [11].

The gathered data will be displayed on the dashboard and a GUI also have been designed to generate alerts against the parameters of the patient's health. Moreover, the parameters will be collected from sensors, and analysis of data saved in the Cloud to check for abnormalities in health conditions [12].

2.1.1 Artificial Intelligence

Despite integrating, health monitoring systems based on artificial intelligence there are many other scopes of patient monitoring systems including industrial management, and physical education [13]. A patient is monitored by using fuzzy logic with the help of sensors and data is also processed by special algorithms to decide on the real-time condition of a patient's health [14]. In [15], Artificial intelligence has been applied in health areas. However, there are many application of AI in health, particularly in narrating the negative results of COVID-19. The recent investigation gives the instruction that we are learning on the 4.0 industrial revolution and the corresponding SDGs. AI plays a vital role in challenging the negative results of COVID-19. Artificial intelligence has been proven helpful in care and health assessment of COVID-19 patients. This technique has been implemented in tracing the COVID-19 at various standards such as surgical applications. AI has been helpful in COVID-19 research by providing the data analysis, and medicine improvement.

2.1.2 Fuzzy Logic

In [16], the fuzzy logic system is designed to improve the healthcare system through accurate and less time diagnosis. In [17], health care systems based on various kinds of technology are discussed and mainly focused on the benefits and limitations of the technologies used in health caring systems. The word fuzzy means ambiguous things. Sometimes, we face the circumstances when we are uncertain about whether the data is appropriate or not, wherein fuzzy logic provides thinking for such data conditions. It is a strategy based on the rules. Fuzzy Rule-Based System (FRBS) is a rarely used technique in healthcare that works with the help of Fuzzy Inference Systems (FIS). FRBS applies if-then rules for data depiction [18]. Besides this, clump and categorization methods are also used in the medical area. Also, in the area of health systems, Fuzzy inference system and FDSS are determined as the most common techniques [19]. One of the main characteristics of fuzzy logic is that it has ability to improve the mistakes and uncertainties of any situation. Fuzzy logic is not used for the logic of absolute correct and absolute incorrect vale, but it is used for partially true and partially false values.

2.1.3 Vital Signs Parameters

A movables temperature quantification can be used in health care applications [20]. For the protection of different diseases, internet of things (IoT) could be used for medical care assistant [18]. A proposed study was made to display the health of students through IoT based cordless architecture that has the ability that data can be sent to the parents at the real time. [21]. In the same way, an health detection system based on AI was developed by some seeker that integrated the measurement of the body's vital parameters such as Photoplethysmography, Echocardiogram, and body hotness for identifying the patient's health status. In addition to these, the consideration about the issues related to safety concerned in IoT-based smart health systems. It found out the cordless health monitoring system for ill persons having a real-time tracking characteristic for location detection with the integrated GPS system. The system is connected to a Wi-Fi system interface through Application Programming Interface (API) to indicate the recovery and health status of the patient. The same structure design used for detection of Covid-19 patients that could help in identifying Covid-19 [22]. The developed system consists of three levels i.e. information taking level, data division level, and application level. Most of the health systems dipped in a few problems such as delays in communication, time interval, etc. To solve these problems, a fog computing system is implemented along with data extracting coding [23]. Therefore, based on these deficiencies in the previous works, in this project, a prototype of a smart patient health monitoring system will be developed. So, different sensors will be deployed to monitor the vital parameters of the patients as well as COVID-19 prediction. The gathered data will be displayed on the LCD and an AI check the sentence. Moreover, the system's-controlled parameters will be changed according to the health of the patient. Data from the patient will be monitored bring real-time and results will be shown on the LCD.

Table 2.1: Literature review summary

Sr. No	Author	year	Proposed work	Limitation
1	Hong-Tan	2020	Ambient Intelligence automated health monitoring in post-pandemic life	Real-time Graphical User Interfacing was missing

2	S.S. Vedaie	2020	Surveillance monitoring system in post-pandemic life	No record of keeping previous patient health
3	O. Taiwo	2020	Smart healthcare patient monitoring during Covid-19 quarantine	Medicine recommendation on the smart monitor was missing
4	Jeddi	2021	Smart sensors inpatient monitoring using artificial intelligence.	Real-time monitoring criteria were missing
5	Zied Kechaou	2021	Multi-agent-based fuzzy logic healthcare decision support system	No method of discarding unnecessary information
6	Rahaman	2021	Different kinds of AI based health caring systems were developed but mainly focused on the merits and demerits of the method used in these systems.	Real-time monitoring of patients' criteria was missing
7	Huang	2022	A temperature measuring band was used in medical systems.	No result satisfaction of patient data
8	Albahri	2022	An IoT-based telemedicine system was for disease detection and health promotion system	No record of previous patient data
9	Bassam	2022	cordless health monitoring system for ill persons having a real-time tracking characteristic for location detection with the integrated GPS system	Not any concept of diagnosing a COVID-19 scenario

10	Paganelli	2023	A conceptual IoT-based system for warning alerts for remote detection of COVID-19 patients in hospitals and at home.	Vital signs used in this experiment are so limited.
----	-----------	------	--	---

2.2 Proposed work

This project will include the following outcomes according to techniques presented in Table 2.2.

Table 2.2: Techniques enhancement using smart patient health monitoring system

Sr.	feature	technique
1	Local control	Manual control for users
2	Automatically control	System controlled by sensors
3	Semi-automatic	Controlling from the internet cloud
4	Monitoring and controlling	Analysis and varying parameters
5	Graphical interface	Data visualization

2.3 Advantages of the proposed system

The health monitoring system provides benefits by analyzing the health conditions of the patients. It is used for monitoring the real-time data of the patients. This system is used for measuring the oxygen level in the blood, heart beat rate, and temperature of the human and also display the results on LCD and web-based platform. This system gives a number of benefits to the patients by providing more possibilities for communication, thereby powering the relationship and improving patient satisfaction and commitment. A satisfied perception is provided to the patients so that their assistant is regularly taking care of them. The key benefits of the proposed system are shown in Table 2.3.

Table 2.3: Key benefits of the patient monitoring system

Sr.	Key benefits
1	Automatic record of patient's vital signs
2	Provision of alarms in monitoring screens
3	Real-time data monitoring
4	Graphical display of data of the patients
5	Enhance the health care system.

2.4 Conclusion

In this chapter, a prototype of an intelligently controlled AI-based patient monitoring system will be developed. Here, various sensors will be deployed to monitor vital signs such as body temperature, heart rate, and blood oxygen level. The collected data will be displayed on the dashboard and a GUI is also designed to control the parameters of the vital signs of the patients. Moreover, the system's-controlled parameters will be changed automatically as per the requirements. We proposed this project by overcoming above limitations so that it can only be based on the latest technology and anyone can use it.

CHAPTER 03

SIMULATION & RESULTS

3.1 Introduction

The optimized and controlled environment for the advancement of the Patient Health Monitoring System (PHMS) is implemented. The simulation of the proposed project is accomplished in Proteus. All the parameters of PHMS are being monitored and controlled. Arduino is an open-source circuit board with input and output pins and micro controller for communication and controlling LED, and buttons, etc. Arduino controller is used for the interfacing of sensors to analyze vibrant scenarios. The AI-based technique, Fuzzy logic is developed for users to analyze the patient's data in graphical form. The flowchart and Proteus results are presented in the following sessions.

3.2 Methodology

In the simulation, the vital signs of the patients are measured by interfacing the sensors and the graphical representation of data is also shown by using the Fuzzy logic technique. The following steps are followed.

- ◆ Fetching the data from sensors to analyze vibrant scenarios.
- ◆ Sending Data to the serial port for serial communication.
- ◆ A virtual Serial Port Driver (VSPD) use for creating serial ports.
- ◆ Monitoring and controlling of scenarios.
- ◆ ThingSpeak cloud is importing data from VSCODE for Graphical representation.
- ◆ Data can be exported from the cloud in the form of a CSV file for further analysis.
- ◆ ThingSpeak cloud is a platform that is used as GUI for users.
- ◆ The graphs are updated on the cloud as sensors value are getting changed in Proteus.
- ◆ The Real-Time data is uploaded from Proteus to the cloud.

3.3 Main components

The main parts of the project contain:

- ◆ Arduino UNO
- ◆ Body Temperature Sensor
- ◆ Heart Rate Sensor
- ◆ SpO₂ sensor
- ◆ LCD Display Module
- ◆ Com port

3.4 Sensors Mathematical calculations

MAX30102 is utilized to detect the blood oxygen level and heart rate in the patient's body. In case of blood saturation level, the Red light and Infrared lights are absorbed by oxygenated blood molecules and remaining light will transmit and absorbed by the photo-diode sensor. λ_1 is wavelength of red light. λ_2 is the wavelength of infrared light The Blood saturation level (SpO₂) is calculated by using the following equations:

$$r = \lambda_{1r} / \lambda_{2r} \quad (3.1)$$

where

λ_{1r} = wavelength of red light absorbed by the oxygenated blood molecules

λ_{2r} = wavelength of light transmitted by oxygenated blood molecules

Heart rate is also detected by the MAX30102. Heart rate is the ratio of upper peak (crest) of oxygenated blood to the lowest peak (trough) of de-oxygenated blood.

$$\text{BPM} = \text{HB}_c / \text{HB}_t \quad (3.2)$$

Where

HB_c = Peak value of oxygenated blood

HB_t = Peak value of de-oxygenated blood

c = crest

t = trough

3.5 Algorithm Flowchart

Esp-32 controller is used here as a platform to sense the parameters through sensors and to control the vibrant scenario of the Patient Monitor. The controller collects the values from sensors. According to threshold limits the controller will implement the commands. DS18B20 is sensing the body temperature. The body temperature of a person ranges from 98F to 104F. If the temperature of the body is greater than 100 F then the person is suffering from fever and values are shown on LCD and graphically. Oxygen level ranges from 90% to 100%. If a person has blood oxygen level value less than 90 the person could quickly lead to serious decline. The heart rate of a healthy person ranges from 50 bpm-99 bpm. If a person has a heart rate less than this range, then it may lead to bradycardia. Figure 3.1 shows the simulation's flowchart.

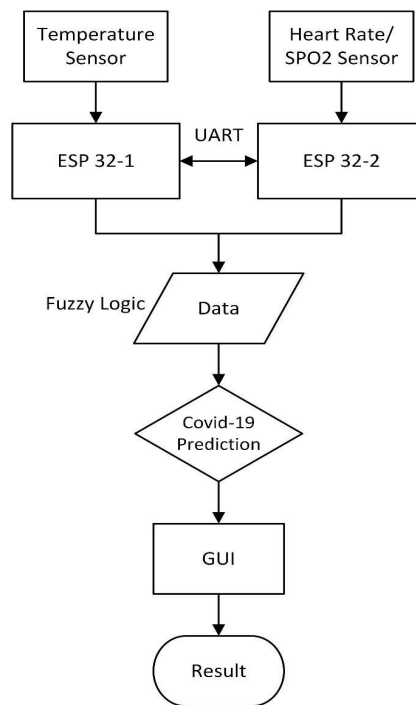

Figure 3.1: Flowchart of the procedure of COVID monitoring system using Fuzzy logic

Moreover, for different people, the vital parameters are changed according to the health condition of the patients. Meanwhile, the advantage of this technique is that virtual data is fetched from Proteus, sent onto the cloud and GUI is developed.

3.6 Simulation Results

The implemented Proteus circuit diagram of the project is shown in Figure.3.2. In our project simulation, real-time data of vital sign parameters is displayed on Cloud Dashboard. The controller gathers data from sensors and observes the output results to optimize the environment.

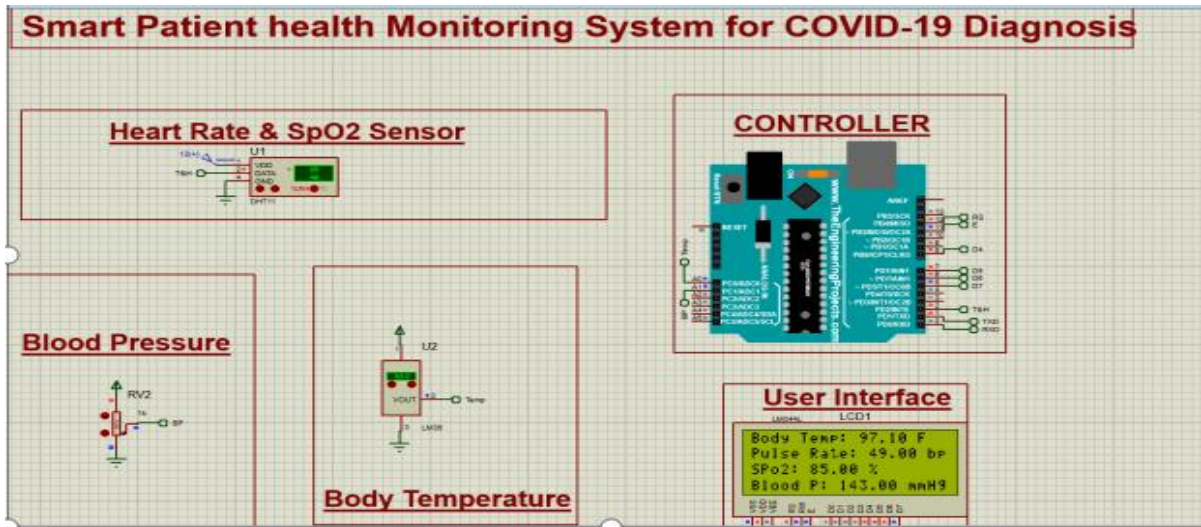

Figure 3.2: Implemented circuit diagram in Proteus software

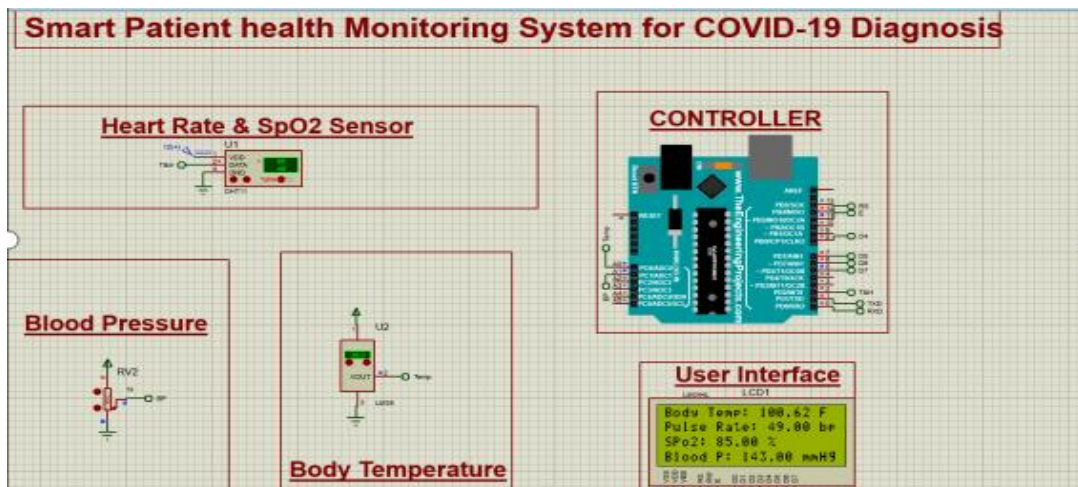

Figure 3.3: Interfacing of sensors with updating parameters values

Figure 3.3 describes the patient monitor parameters. The changing values of the vital signs will show corresponding change in results on the LCD. The simulation result has been presented in four scenarios given below.

1. Body temperature monitoring.

2. Oxygen level monitoring.
3. Heart rate monitoring.

3.6.1 Body temperature and SpO₂ monitoring

DS18B20 senses the body temperature of a human. The changing values of temperature vary from the normal range shown on the LCD. When the value of temperature increases from the normal range, an alert on the LCD is displayed. The increasing value of the temperature also includes the symptoms of the person suffering from COVID-19 disease. Figure 3.4 describes the values of body temperature and oxygen level of a patient for COVID-19 prediction.

MAX30102 sensor is used to find out the level of blood oxygen in the blood. The varying values of the haemoglobin in the blood can be monitored on the LCD and also on the ThingSpeak platform. The value of oxygen level ranges from 90% to 100%. If the patient's SpO₂ value is less than 90 percent then an alarm is alerted on the LCD. The patient suffering from COVID-19 also has a blood oxygen level of less than 90 percent.

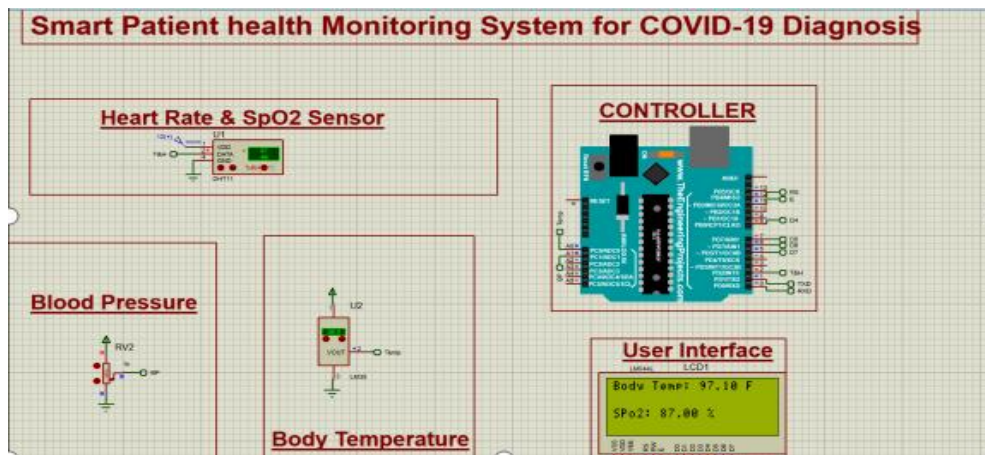

Figure 3.4: Body temperature and SpO₂ interfacing

3.7 Graphical representation of Sensors data

The data collected from the Proteus is serially sent to Cloud through serial communication protocol. Data is graphically represented on the cloud in the three different fields. Field 1 represents Body Temperature, Field 2 represents Heart Rate and Field3 is represents SpO₂ . Moreover, the data can be fetched in the CSV file for analysis. Meanwhile, the fetched data can be used to enhance the monitoring strategy using artificial intelligence (AI) The results are shown in Figure 3.5.

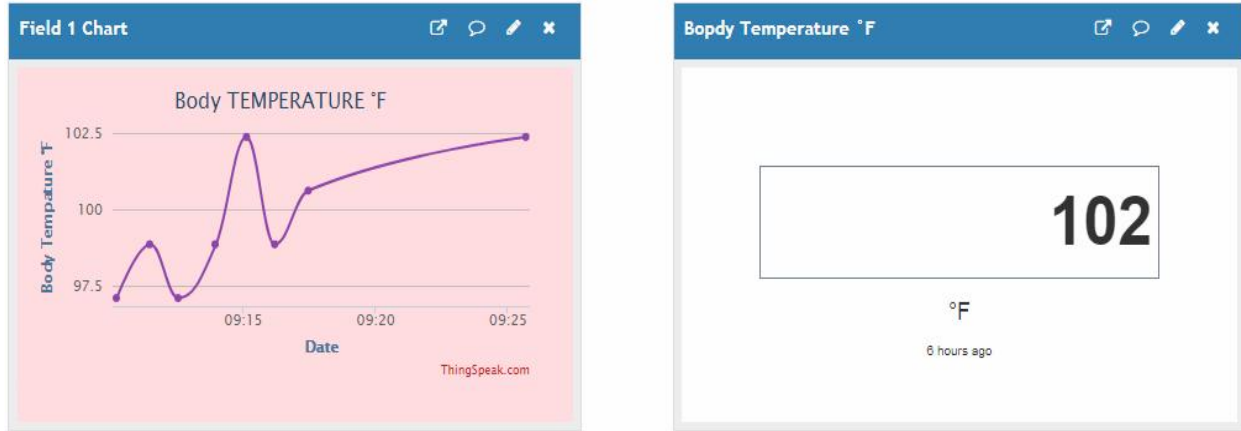

Figure 3.5: Graphical representation of patient's body temperature

In Figure 3.6, heart rate of a human heart is shown. This is the real-time data of the heart rate of the patient. We can check the results whenever we want.



Figure 3.6: Graphical representation of patient's heart rate

In Figure 3.7, a graphical representation of Blood Oxygen level (SpO₂) is shown below. This shows the real-time data of blood oxygen levels in the blood.

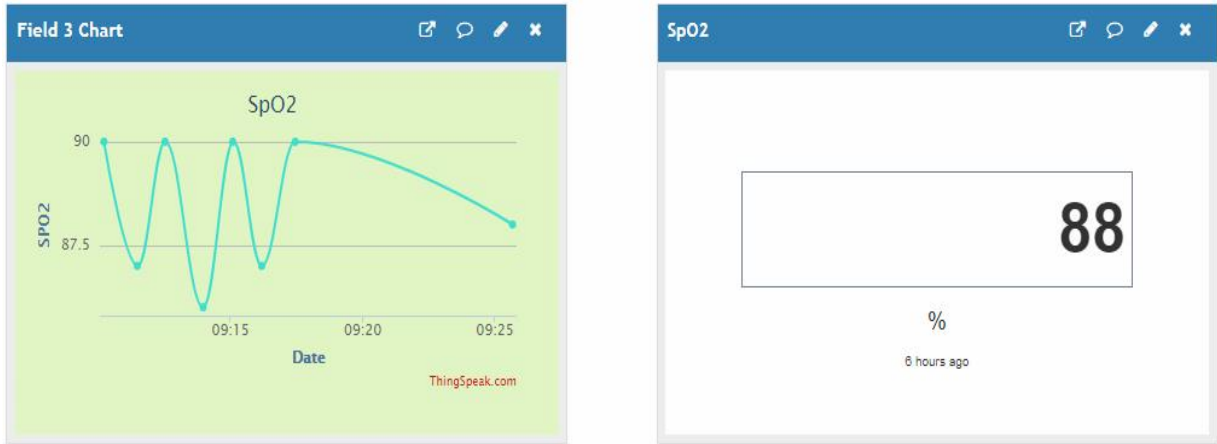

Figure 3.7: Graphical representation of patient's blood oxygen level (SpO₂)

3.8 Importing Data from the Cloud

The data obtained from the cloud-stored in the excel data sheet, furthermore this data can be used in AI technique to improve performance. This excel sheet shows the values of vital signs of a patient at real time and time wise changing scenarios as shown in Figure 3.9.

	A	B	C	D	E	F
1	created_at	sr. no	Temperature	Heart Rate	SpO2	Blood Pressure
2	Date: 2023-02-21T09 Time: 10	1	97.1	50	90	123
3	Date: 2023-02-21 time: 09:11	2	98.1	48	87	133
4	Date: 2023-02-21 Time 09:12:	3	99.1	50	90	143
5	Date: 2023-02-21 Time: 09:13	4	100.1	45	86	133
6	Date: 2023-02-21 Time:09:15	5	101.1	50	90	143
7	Date: 2023-02-21 Time:09:16	6	102.1	47	87	113
8	Date: 2023-02-21 Time: 09:17	7	103.1	50	90	143
9	Date: 2023-02-21 Time: 09:25	8	104.1	48	88	143

Figure 3.8: Real-time data obtained from the interfaced cloud

Data of the patient is uploaded concerning date and time.

3.9 Conclusion

In this chapter, the main focused is on the simulation of the smart Patient Monitoring System. It provides an optimized and controlled system for monitoring the patients at real time. Moreover, the system is designed to send data serially on the ThingSpeak Cloud and is shown as GUI. Meanwhile, the simulation is designed according to the vital parameters. Furthermore, the data was obtained in the form of CSV files.

CHAPTER 04

HARDWARE IMPLEMENTATION

4.1 Introduction

By integrating advanced sensors and wearable devices, the hardware components of the project enable continuous detection of vital signs, including temperature of the body, heart rate, and blood oxygen level. This innovative system is purposed to facilitate early detection and diagnosis of COVID-19 symptoms, allowing for prompt medical interference. The hardware implementation ensures logical data collection, transmission, and analysis for effective patient care and management in the fight against the pandemic. The development of mechanical structure of the patient monitor is explained in following sections.

4.2 Block Diagram

To real time develop this project, the proposed block diagram is presented in figure 4.1.

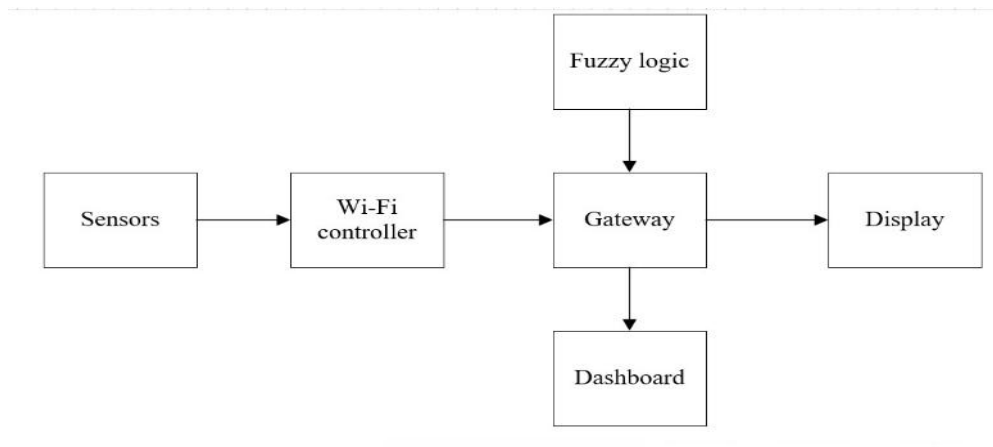

Figure 4.1: Block diagram of hardware

4.3 Schematic Diagram

The proposed schematic diagram is shown in figure 4.2.

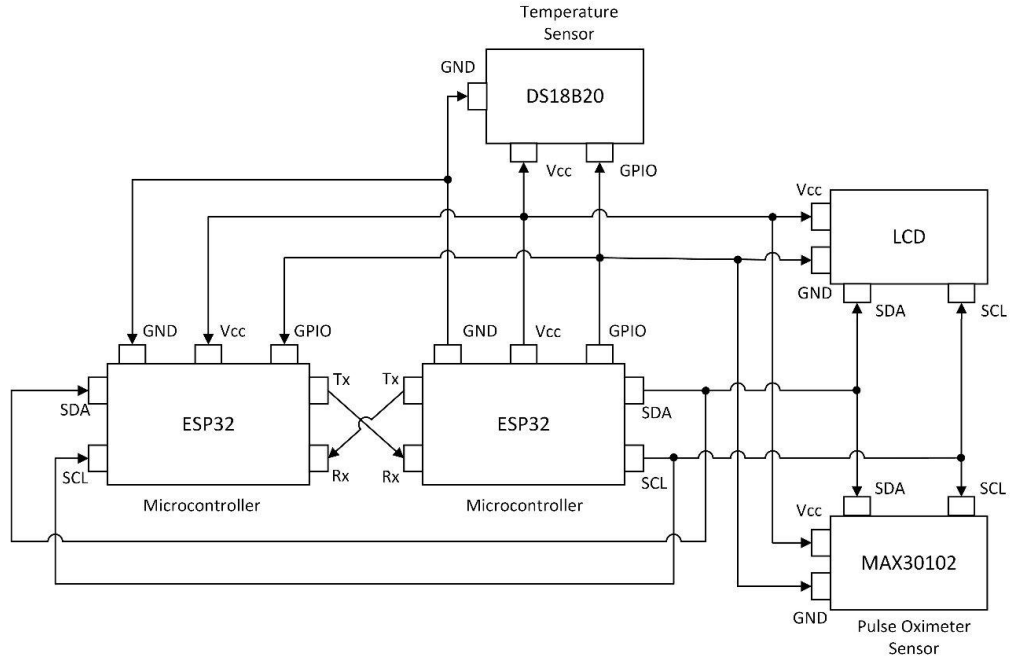

Figure 4.2: schematic diagram of the proposed system

4.3 List of Components

Table 4.1: List of Equipment's

Sr. No	Equipment's	Amount
1	DS18B20	1
2	LCD(20x4)	1
3	ESP-32	2
4	MAX30102	1
5	Vero Board	1

4.3.1 DS18B20

DS18B20 temperature sensor is a digital sensor that can be used to measure hotness of body in various applications [23] as shown in figure 4.2. A single wire interface is used in the DS18B20 temperature sensor for communication purposes, which simplifies the wiring and reduces the number of pins required. The sensor is capable of detecting temperature changes as small as 0.0625°C and provides accurate temperature readings with a maximum error of $\pm 0.5^{\circ}\text{C}$. The sensor

has a large temperature range of -55°C to 125°C . Its conversion time for a 12-bit resolution reading is 750ms, which is relatively fast compared to other temperature sensors.

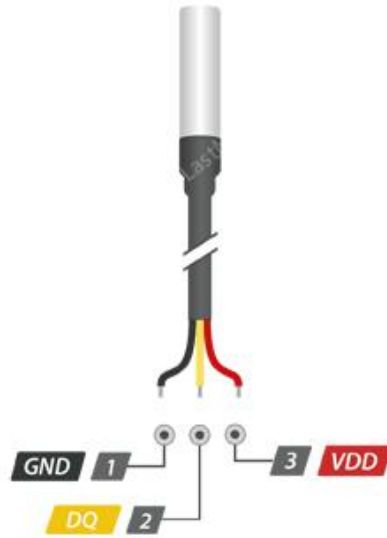

Figure 4.3: DS18B20 temperature sensor

Specifications:

The specifications of Body temperature sensor are presented in the Table 4.2.

Table 4.2: Specifications of Body Temperature sensor

Sr. No	Parameters	Values
1	Accuracy	$\pm 0.5^{\circ}\text{C}$ in the range of -10°C to 85°C
2	Temperature's range	-55°C to 125°C
3	Supply voltage	3V to 5.5V
4	Resolution	9 to 12 bits selectable
5	Current consumption	1mA max (during temperature conversion)
6	Output	Digital, 1-wire interface
7	Conversion time	750ms (12-bit resolution)

4.3.2 LCD

In a 20×4 LCD module, there are four rows in display and in one column twenty pins can be shown and in a single presentation 80 characters may be proven. This fluid gem module makes use of HDD44780 (It is a regulator used to expose monochrome textual content suggests) identical speaking. The fluid gem display communicating code is efficiently available. We just required eleven facts and result pin outs for the communicating of the LCD screen shows in figure

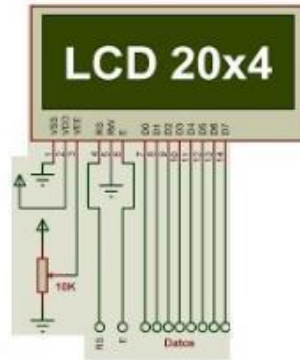

Figure 4.4: LCD Configuration

Features:

Features of the LCD (20×4) are:

- ◆ The main component of this module is that it can show 80 characters all at once.
- ◆ The cursor of this module has 5x8 (40) dabs.
- ◆ On this module previously collected the controller of RW1063.
- ◆ This module works on the in addition to five volts input supply and can likewise deal with the in addition to three volts.

20*4 LCD Pinout:

These are some pin outs of the LCD (20×4) modules that are explained in table 4.3

Table 4.3: Properties of 20x4 LCD

Pin No	Pin Name	Parameters
1	VSS	It is ground pinout which is zero.

2	VDD	5 Volts are provided
3	VO	Set the contrast of screen
4	RS	Used for H/L selected signal
5	R/W	Used for H/L Read and Write
6	E	Used for H/L Enable Signal
7	DB0	Used for H/L data bus for 4 or 8 bit mode
8	LED+	Set back light anode
9	LED-	Set back light cathode

4.3.3 ESP-32

The job of Wi-Fi regulator here is to get information from the sensors and send that information to passage. In this undertaking two ESP32 regulators are utilized. In this project, ESP-32 is used for data acquisition, data processing, and real-time monitoring. The elements of this regulator are given beneath:

ESP32 assumes a significant part in AI applications. It comprises of Wi-Fi module and Bluetooth module. It is for the most part utilized for inserted framework project. Its features are given below:

The pin configuration of ESP32 controller is shown in Figure .

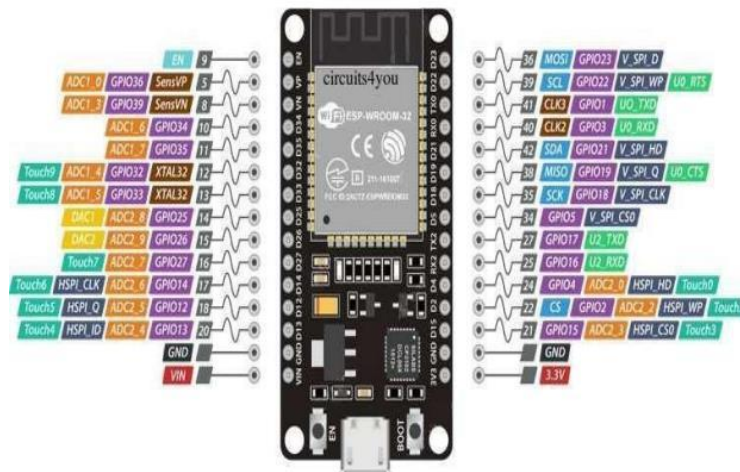

Figure 4.5: ESP32 Controller

The specifications of Esp32 are presented in table 4.4.

Table 4.4: Specifications of EP32 Controller

Sr. No	Specifications	ESP32
1	CPU	Dual Core
2	SRAM	520 KB
3	ROM	488KB
4	USB	None
5	CAP Touch	10
6	12s	12
7	Wi-fi	802.11
8	Raspberry pi	Pi 4 model A

4.3.4 Pulse rate and blood oxygen sensor (MAX30102)

The pulse rate and blood oxygen measuring sensor is an integrated pulse oximeter and heart-rate monitor module. It is designed to accurately find out the oxygen saturation level in the blood and heart rate in various applications.

The sensor contains a combination of red and infrared LEDs along with a photo-detector to detect the absorption of light by oxygenated and de-oxygenated blood. By analyzing the reflected light intensity, the sensor can determine heart beat rate and SpO₂ (blood oxygen) levels. The MAX30102 [24] is shown in the figure 4.5.



Figure 4.6: MAX30102 sensor

4.3.5 Vero Board

Vero board, which is also known as strip-board, is a type of prototyping board commonly used in electronics and electrical engineering. It provides an easy platform for soldering electronic components and creating custom circuit designs. This board provides a cost-effective and accessible option for prototyping and experimenting with electronic circuits. It allows for the construction of circuit designs without the need for specialized equipment or PCB fabrication.

4.4 Development of Prototype

Basically, in the development phase of prototype, The temperature and SpO₂ sensor are connected to one of the input pins of the ESP32 module, typically using digital or analog interfaces such as I2C , ADC or UART . ESP-32 modules are connected with each other through UART, that enables serial communication between both modules. After acquiring data from the temperature sensor and heart rate/SpO₂ sensor, the ESP32 module performs data processing tasks. This includes analyzing, filtering, and interpreting the sensor data to extract meaningful information.

Fuzzy logic technique is implemented in the data processing stage. It is used for handling uncertain or imprecise data by defining linguistic variables and rules. Fuzzy logic can be used to make decisions or draw conclusions based on the processed sensor data, enhancing the accuracy and adaptability of the monitoring system .By using this technique, COVID detection is accurately and easily monitored. The graphical user interface (GUI) provides a user-friendly interface to interact with the health monitoring system. It displays the real-time sensor data, vital signs, and COVID results.

4.4.1 Front page

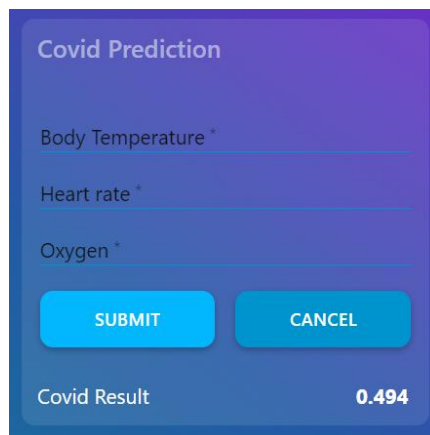

Figure 4.7: Front page of Dashboard

4.4.2 Dashboard of the proposed project

A dashboard is a optical representation of all the data. It can be used in different ways, its primary purpose is to provide information. In dashboard, we can see real time data of our sensors which is shows in Figure 4.8. With the help of dashboard we can control field devices. In dashboard there are four keys point which are below:

Front page

Field Device Control

API Setting

Profile setting

In overview we can see temperature, SpO₂, heart rate value and COVID prediction at the output of our project. All data of our sensors are stored in dashboard as per the requirement of the patient we can check whenever we want.

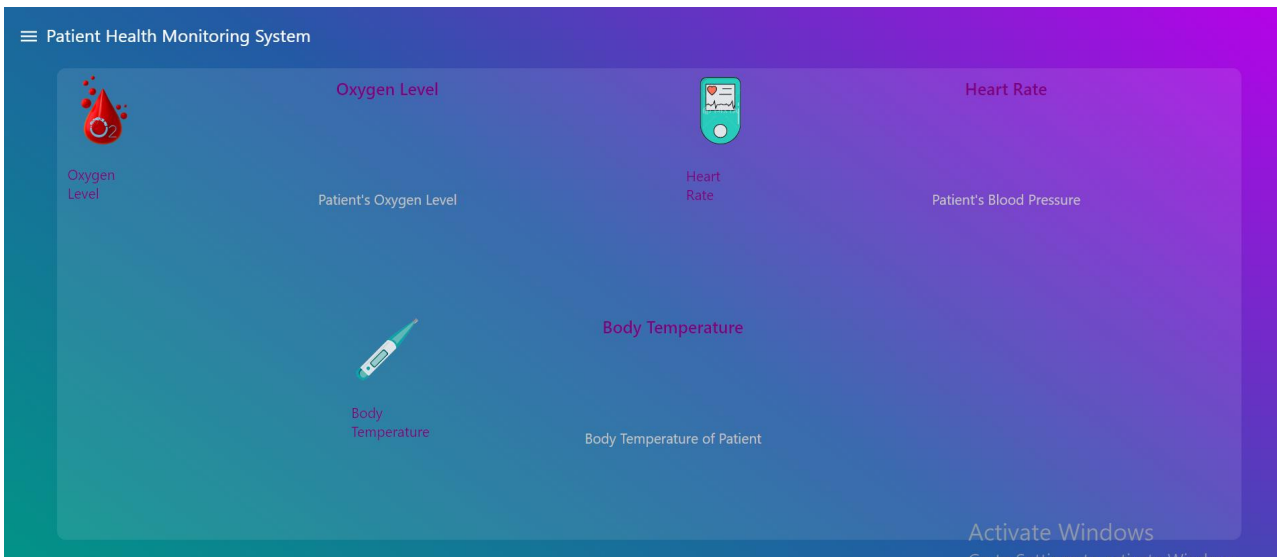

Figure 4.8: Dashboard

Figure 4.9 shows the graphical content of sensors in real-time.

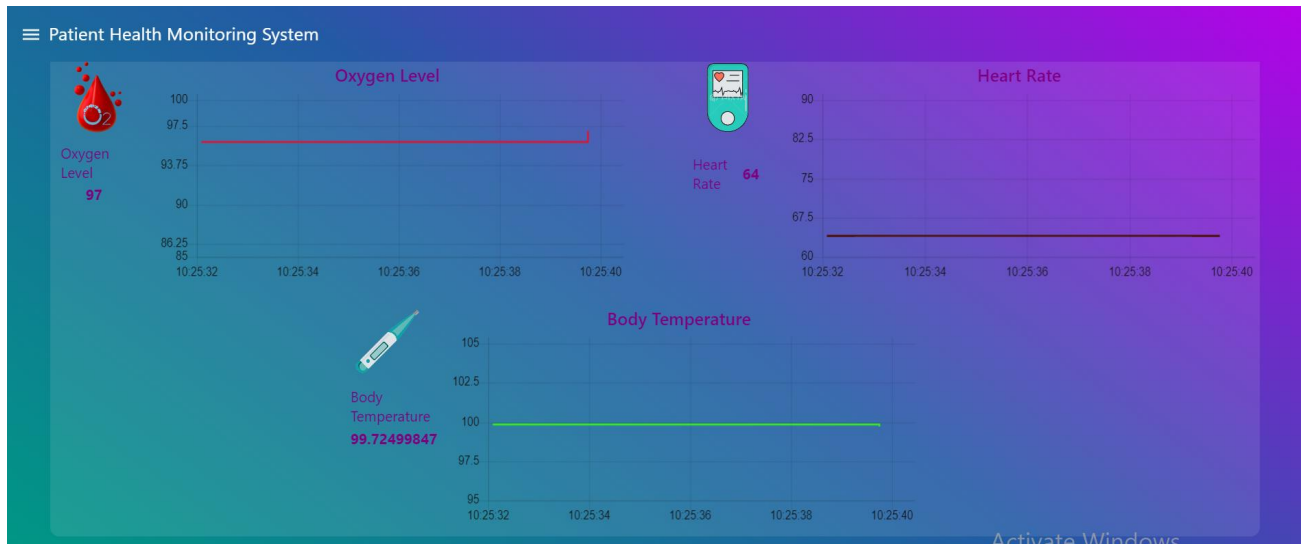

Figure 4.9: Graphical content of vital signs on Dashboard

4.4.3 Hardware implementation

The prototype of patient health monitoring system is given below in figure 4.6.



Figure 4.10: Prototype of circuit diagram

The above figure shows the hardware implementation circuit diagram of the proposed system. This system describes the working of a patient monitoring system for COVID detection.

4.4.1.1 When person's temperature and heart rate/SpO₂ is not measured

When the finger is not placed on the MAX30102 sensor the LCD shows zero values of heart rate and blood saturation level. And when the body temperature of a person is not detected by the temperature sensor then LCD shows a random value for body temperature as shown in Figure 4.7.

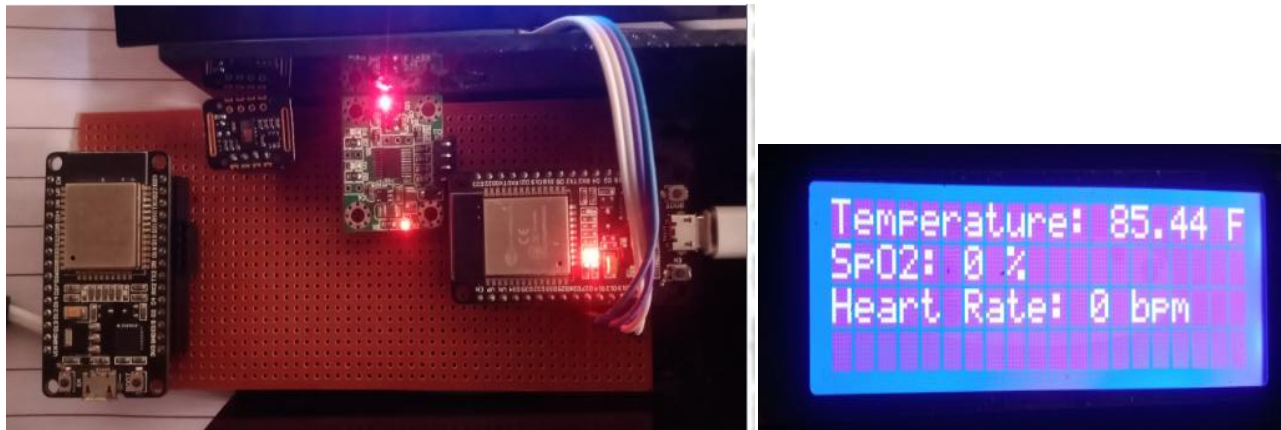

Figure 4.11: LCD result when no temperature and heart rate/SpO₂ is measured

4.4.1.2 When person's temperature and heart rate/spO₂ are measured

The output of the circuit, when a person's body temperature and heart rate / SpO₂ are measured, is shown in Figure 4.8.

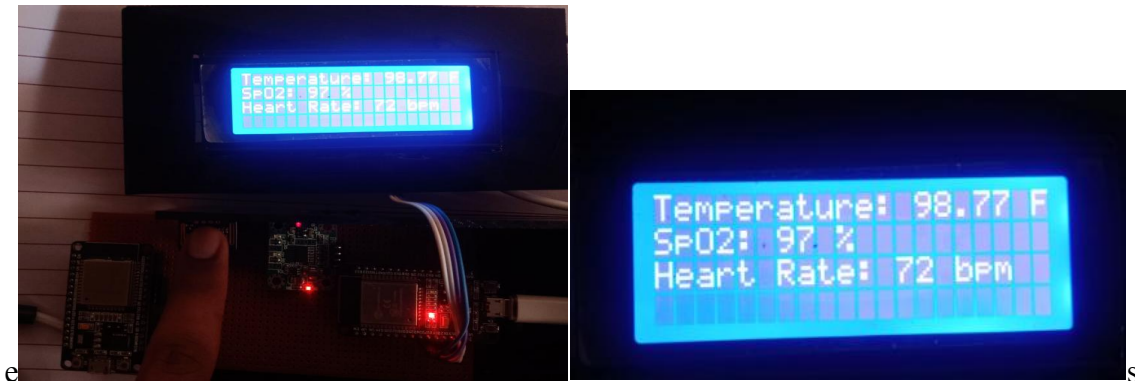

Figure 4. 12: LCD result when a person's temperature and heart rate/SpO₂ is measured

4.5 Design Calculation

4.5.1 DS18B20

This sensor is used to detect the person's body temperature. This sensor contains three pins, Vin pin , where input voltage are applied, ground and Vout pin, which is connected to the GPIO pin of the ESP-32. when the heat is increased, resistance of the sensor increased due to which current reduce and voltages increase. The ratio or output and input voltages are converted from analogue to digital converter through ADC converter.

$$T = V_{out} / V_{in} \quad (4.1)$$

V_{in} = input voltages of the sensor

V_{out} = output voltages of the sensor

4.5.2 MAX30102

MAX30102 is used to detect the blood saturation level and heart rate in the patient's body. In case of blood saturation level, the Red light and Infrared lights are absorbed by oxygenated blood molecules and remaining light will transmit and absorbed by the photo-diode sensor. λ_1 is wavelength of red light. λ_2 is the wavelength of infrared light The Blood saturation level (SpO2) is calculated by using the following equations:

$$r = \lambda_{1r} / \lambda_{2r} \quad (4.2)$$

where

λ_{1r} = wavelength of red light absorbed by the oxygenated blood molecules

λ_{2r} = wavelength of light transmitted by oxygenated blood molecules

Heart rate is also detected by the MAX30102. Heart rate is the ratio of upper peak (crest) of oxygenated blood to the lowest peak (trough) of de-oxygenated blood.

$$\text{BPM} = \text{HB}_c / \text{HB}_t \quad (4.3)$$

Where

HB_c = Peak value of oxygenated blood

HB_t = Peak value of de-oxygenated blood

c = crest

t = trough

4.6 Conclusion

This chapter comprises of implementation of the hardware and the discussion of the components used and the specifications of the components along with their experimental realization. Basically, connectivity between the sensors and the COVID-19 prediction using Fuzzy logic is provided by the AI-based framework. In this project, we have not only proposed project of an intelligent health monitoring system for COVID-19 detection but will also display it on a digital platform. Moreover,

the hardware implementation is done by interfacing ESP-32 with sensors and serially communicating with CloudSpeak to send data to the gateway where the server of the application access this real-time data and displays it on the dashboard.

Chapter 05

FUZZY LOGIC FOR RELIABILITY OF COVID-19 PREDICTION

5.1 Introduction

Fuzzy logic is an artificial intelligence technique that plays a critical role in the development of patient health monitoring system projects. Fuzzy logic allows us to handle uncertainty and imprecise data, which is often encountered in diagnosis and prediction.

In the context of COVID-19, fuzzy logic is used to develop a predictive model that can estimate the probability of an individual being infected with the virus. Traditional binary classification models may struggle to capture the complexities and uncertainties associated with COVID-19 due to its symptoms. By implementing fuzzy logic, the smart patient health monitoring system incorporates a more significant approach to COVID-19 prediction. It takes into account multiple input variables such as temperature, heart beat rate, blood oxygen level, and other relevant parameters to assess the possibility of infection.

By utilizing fuzzy logic, the project aims to improve the accuracy and reliability of COVID-19 predictions, helping healthcare experts in making more accurate decisions and enabling early detection and intervention. It provides a more comprehensive approach to diagnosing and monitoring COVID-19 patients, contributing to effective disease management and control.

5.2 Fuzzy Collections/ Sets

Fuzzy sets work on the concept of crisp or actual value. These sets tell the number of the degree of membership such a “0” or “1” or a range of data with limited degree of membership. For example, by considering the high temperature, its range must be between 100 F and higher and it has not any concern with a single value. But the fuzzy set will describe a much bold range for this temperature.

5.3 Fuzzy Logic System Design

The design and development of a fuzzy logic system for COVID-19 detection typically include the input variables, membership functions, rule base, fuzzy inference, and defuzzification.

5.3.1 Input / Output Variables

Input variables used in the project for COVID-19 detection are

- ◆ Body Temperature
- ◆ Heart beat Rate
- ◆ Blood oxygen Level

Output variable for the proposed system include COVID risk.

The input variables [25] are given in the Figure 5.1.

```
import numpy as np
import skfuzzy as fuzz
from skfuzzy import control as ctrl
import matplotlib.pyplot as plt

# Define the input variables (antecedents)
body_temp = ctrl.Antecedent(np.arange(91, 107, 1), 'body_temp')
heart_rate = ctrl.Antecedent(np.arange(20, 131, 1), 'heart_rate')
spo2 = ctrl.Antecedent(np.arange(75, 101, 1), 'spo2')
```

Figure 5.1: Input variables of the proposed systems

The output variable is shown in the Figure 5.2.

```
# Define the output variable (consequent)
covid_risk = ctrl.Consequent(np.arange(0, 1.1, 0.1), 'covid_risk')
```

Figure 5.2: Output variable of the proposed system

The linguistic terms associated with each input variable are

- ◆ Very low
- ◆ Low
- ◆ Normal
- ◆ High

5.4 Fuzzification and Membership Functions

Fuzzification consists of two mechanisms, construct the membership functions for input and output variables and express them with linguistic variables. This process is same as to map the classical set to fuzzy set of varying degrees.

In fuzzification, membership functions describe the degree to which an input value relates with a specific linguistic term within a fuzzy logic system as mentioned earlier. They map the crisp input values to fuzzy values, indicating the degree of membership to a particular linguistic term. Here is a brief explanation of membership functions for each linguistic term of the input variables

5.4.1 Body Temperature

Linguistic terms include in body temperature membership functions are very *low*, *Low*, *Normal*, *High*. Membership Functions used in the proposed system is Triangular or Trapezoidal functions. The representation of membership functions are given as:

Low: The membership function for "Low" starts with a low value and increases gradually towards the center.

Normal: The membership function for "Normal" has a peak at the center, indicating the range of typical body temperatures.

High: The membership function for "High" starts with a high value and decreases slowly towards the center.

Very High: The membership function for "Very High" starts with a very high value and decreases slowly.

5.4.2 Heart Rate

Linguistic Terms includes in heart rate are *low*, *Normal*, *High*. Triangular or Trapezoidal functions are typically used. Membership functions are explained below:

Low: This membership function starts with a high value and decreases slowly towards the center.

Normal: This membership function has a peak at the center, representing the range of heart rates.

High: This membership function starts with a low value and increases gradually towards the center.

5.4.3 Blood Saturation Level

Linguistic Terms includes *Critical*, *Low*, *Normal*. Triangular or Trapezoidal functions are commonly employed here.

Critical: The membership function for "Critical" starts with a low value and increases gradually towards the center.

Normal: The membership function for "Normal" has a peak at the center, representing the range of typical oxygen levels.

High: The membership function for "High" starts with a high value and decreases slowly towards the center.

Table 5.1: Membership functions of Fuzzy sets

Parameter	Range	Membership function range
Blood Oxygen Level	$75 \% \leq \text{Blood Oxygen level} \leq 99 \%$	$75 \% \leq \text{Critical} \leq 90 \%$ $87 \% \leq \text{Low} \leq 95 \%$ $94 \% \leq \text{Normal} \leq 99 \%$
Body Temperature	$91 \text{ F} \leq \text{Body Temperature} \leq 106 \text{ F}$	$91 \text{ F} \leq \text{Low} \leq 97 \text{ F}$ $96 \text{ F} \leq \text{Normal} \leq 100 \text{ F}$ $98 \text{ F} \leq \text{High} \leq 102 \text{ F}$ $100 \text{ F} \leq \text{Very high} \leq 106 \text{ F}$
Heart Rate	$20 \text{ bpm} \leq \text{Heart Rate} \leq 130 \text{ bpm}$	$20 \text{ bpm} \leq \text{Low} \leq 70 \text{ bpm}$ $60 \text{ bpm} \leq \text{Normal} \leq 100 \text{ bpm}$ $95 \text{ bpm} \leq \text{High} \leq 130 \text{ bpm}$
Covid Risk	$0\% - 100\%$	$0\% \leq \text{Low} \leq 30\%$ $20 \% \leq \text{Normal} \leq 50\%$ $70 \% \leq \text{High} \leq 100\%$

All above membership functions are created using the python coding as shown in Figure 5.3.

```
# Define the membership functions for each variable
body_temp['low'] = fuzz.trimf(body_temp.universe, [91, 94, 97])
body_temp['normal'] = fuzz.trimf(body_temp.universe, [96, 98, 100])
body_temp['high'] = fuzz.trimf(body_temp.universe, [98, 100, 102])
body_temp['very-high'] = fuzz.trimf(body_temp.universe, [100, 103, 106])

heart_rate['low'] = fuzz.trimf(heart_rate.universe, [20, 45, 70])
heart_rate['normal'] = fuzz.trimf(heart_rate.universe, [60, 80, 100])
heart_rate['high'] = fuzz.trimf(heart_rate.universe, [95, 112.5, 130])

spo2['critical'] = fuzz.trimf(spo2.universe, [75, 83, 90])
spo2['low'] = fuzz.trimf(spo2.universe, [87, 91, 95])
spo2['normal'] = fuzz.trimf(spo2.universe, [94, 97, 100])

covid_risk['abnormal'] = fuzz.trimf(covid_risk.universe, [0, 0.1, 0.3])
covid_risk['normal'] = fuzz.trimf(covid_risk.universe, [0.2, 0.3, 0.5])
covid_risk['high'] = fuzz.trimf(covid_risk.universe, [0.4, 0.6, 0.8])
covid_risk['Risk-Very-High'] = fuzz.trimf(covid_risk.universe, [0.7, 0.8, 1])
```

Figure 5.3: Defining membership function for each variable

The membership function plots of the the vital signs are shown below.

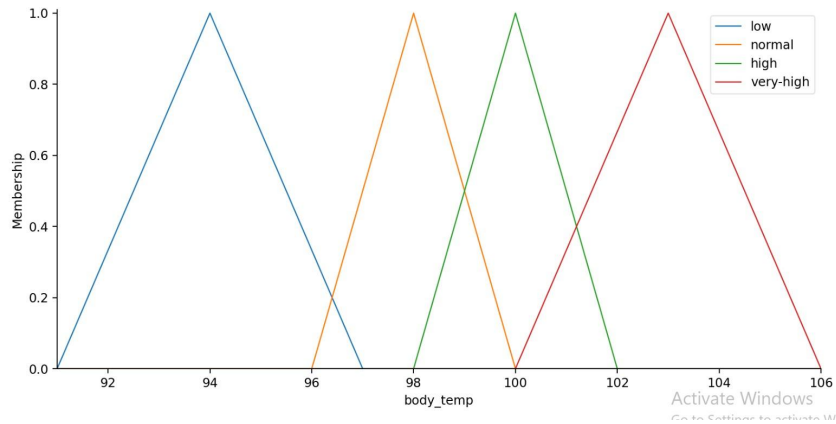

Figure 5.4 Membership graph of body temperature

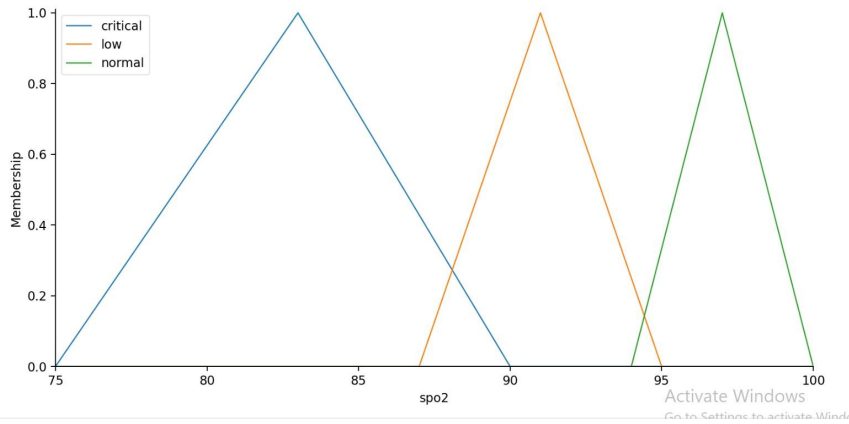

Figure 5.5: Membership graph of blood saturation level

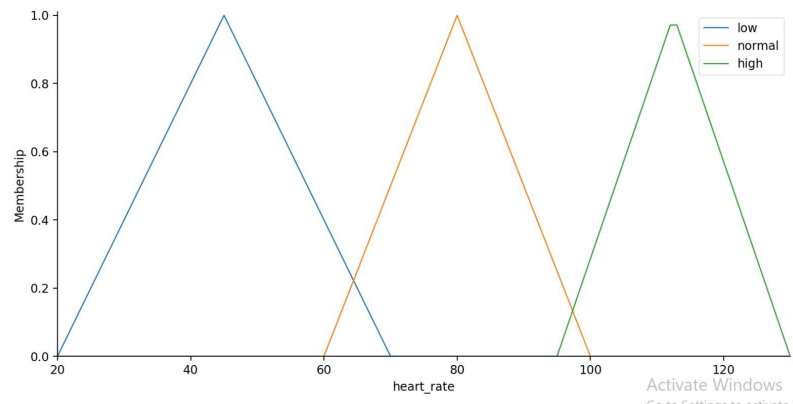

Figure 5.6: Membership graph of heart rate

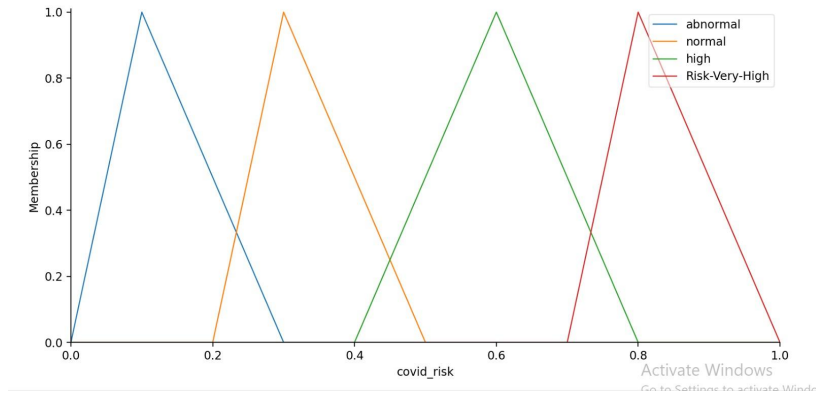

Figure 5.7: Membership graph of COVID risk

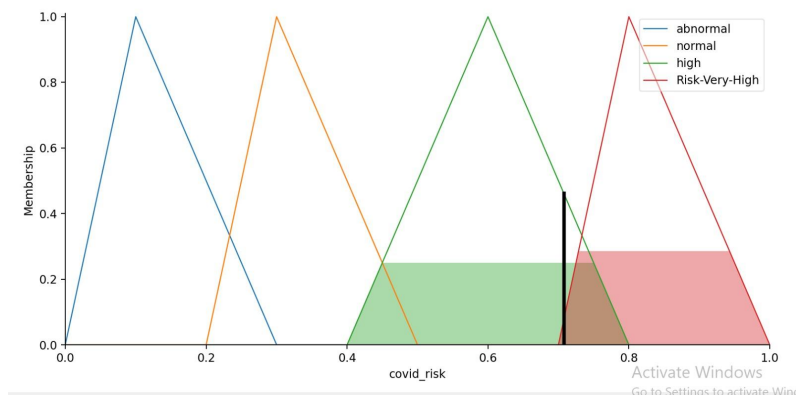

Figure 5.8: Membership graph of COVID risk with indicating level

5.4 Fuzzy Control Rules

The fuzzy inference system is an essential part of fuzzy logic that processes fuzzy inputs, applies fuzzy rules, and produces fuzzy outputs. It mimics decision-making based on imprecise and uncertain information.

In a fuzzy system, the rule base consists of a set of rules that describe the relationships between the input variables and the output (COVID-19 risk detection) in a linguistic form. Each rule in the fuzzy logic system represents a specific combination of input conditions and assigns a corresponding output value or linguistic term.

Figure 5.4 shows the fuzzy rules define for the proposed project according to the fuzzy input variables for COVID -19 detection.

Table 5.2: Fuzzy Rules

Body temperature	Heart Rate	SpO₂	COVID-19 Risk
Low	Low	Low	Abnormal
Low	Low	Normal	Abnormal
Low	Low	Critical	Abnormal
Low	Normal	Low	Abnormal
Low	Normal	Normal	Normal
Low	Normal	Critical	Abnormal
Low	High	Low	Abnormal
Low	High	Normal	Abnormal
Low	High	Critical	Abnormal
Normal	Low	Low	Abnormal
Normal	Low	Normal	Normal
Normal	Low	Critical	Abnormal
Normal	Normal	Low	Normal
Normal	Normal	Normal	Normal
Normal	Normal	Critical	Abnormal
Normal	High	Low	High
Normal	High	Normal	High
Normal	High	Critical	High
High	Low	Low	High
High	Low	Normal	Abnormal
High	Low	Critical	Abnormal
High	Normal	Low	Normal
High	Normal	Normal	Normal
High	Normal	Critical	Abnormal
High	High	Low	High
High	High	Normal	High
High	High	Critical	High
Very high	Low	Low	High
Very high	Low	Normal	High
Very high	Low	Critical	High
Very high	Normal	Low	High
Very high	Normal	Normal	High
Very high	Normal	Critical	Very high risk
Very high	High	Low	High
Very high	High	Normal	High
Very high	High	Critical	Very high risk

```

# Define the rules
rule1 = ctrl.Rule(body_temp['low'] & heart_rate['low'] & spo2['low'], covid_risk['abnormal'])
rule2 = ctrl.Rule(body_temp['low'] & heart_rate['low'] & spo2['normal'], covid_risk['abnormal'])
rule3 = ctrl.Rule(body_temp['low'] & heart_rate['low'] & spo2['critical'], covid_risk['abnormal'])
rule4 = ctrl.Rule(body_temp['low'] & heart_rate['normal'] & spo2['low'], covid_risk['abnormal'])
rule5 = ctrl.Rule(body_temp['low'] & heart_rate['normal'] & spo2['normal'], covid_risk['normal'])
rule6 = ctrl.Rule(body_temp['low'] & heart_rate['normal'] & spo2['critical'], covid_risk['abnormal'])
rule7 = ctrl.Rule(body_temp['low'] & heart_rate['high'] & spo2['low'], covid_risk['abnormal'])
rule8 = ctrl.Rule(body_temp['low'] & heart_rate['high'] & spo2['normal'], covid_risk['abnormal'])
rule9 = ctrl.Rule(body_temp['low'] & heart_rate['high'] & spo2['critical'], covid_risk['abnormal'])

rule10 = ctrl.Rule(body_temp['normal'] & heart_rate['low'] & spo2['low'], covid_risk['abnormal'])
rule11 = ctrl.Rule(body_temp['normal'] & heart_rate['low'] & spo2['normal'], covid_risk['normal'])
rule12 = ctrl.Rule(body_temp['normal'] & heart_rate['low'] & spo2['critical'], covid_risk['abnormal'])
rule13 = ctrl.Rule(body_temp['normal'] & heart_rate['normal'] & spo2['low'], covid_risk['normal'])
rule14 = ctrl.Rule(body_temp['normal'] & heart_rate['normal'] & spo2['normal'], covid_risk['normal'])
rule15 = ctrl.Rule(body_temp['normal'] & heart_rate['normal'] & spo2['critical'], covid_risk['abnormal'])
rule16 = ctrl.Rule(body_temp['normal'] & heart_rate['high'] & spo2['low'], covid_risk['high'])
rule17 = ctrl.Rule(body_temp['normal'] & heart_rate['high'] & spo2['normal'], covid_risk['high'])
rule18 = ctrl.Rule(body_temp['normal'] & heart_rate['high'] & spo2['critical'], covid_risk['high'])

rule19 = ctrl.Rule(body_temp['high'] & heart_rate['low'] & spo2['low'], covid_risk['high'])
rule20 = ctrl.Rule(body_temp['high'] & heart_rate['low'] & spo2['normal'], covid_risk['abnormal'])
rule21 = ctrl.Rule(body_temp['high'] & heart_rate['low'] & spo2['critical'], covid_risk['abnormal'])
rule22 = ctrl.Rule(body_temp['high'] & heart_rate['normal'] & spo2['low'], covid_risk['normal'])
rule23 = ctrl.Rule(body_temp['high'] & heart_rate['normal'] & spo2['normal'], covid_risk['normal'])
rule24 = ctrl.Rule(body_temp['high'] & heart_rate['normal'] & spo2['critical'], covid_risk['abnormal'])
rule25 = ctrl.Rule(body_temp['high'] & heart_rate['high'] & spo2['low'], covid_risk['normal'])
rule26 = ctrl.Rule(body_temp['high'] & heart_rate['high'] & spo2['normal'], covid_risk['normal'])
rule27 = ctrl.Rule(body_temp['high'] & heart_rate['high'] & spo2['critical'], covid_risk['high'])

rule28 = ctrl.Rule(body_temp['very-high'] & heart_rate['low'] & spo2['low'], covid_risk['high'])
rule29 = ctrl.Rule(body_temp['very-high'] & heart_rate['low'] & spo2['normal'], covid_risk['high'])
rule30 = ctrl.Rule(body_temp['very-high'] & heart_rate['low'] & spo2['critical'], covid_risk['high'])
rule31 = ctrl.Rule(body_temp['very-high'] & heart_rate['normal'] & spo2['low'], covid_risk['high'])
rule32 = ctrl.Rule(body_temp['very-high'] & heart_rate['normal'] & spo2['normal'], covid_risk['high'])
rule33 = ctrl.Rule(body_temp['very-high'] & heart_rate['normal'] & spo2['critical'], covid_risk['Risk-Very-High'])
rule34 = ctrl.Rule(body_temp['very-high'] & heart_rate['high'] & spo2['low'], covid_risk['high'])
rule35 = ctrl.Rule(body_temp['very-high'] & heart_rate['high'] & spo2['normal'], covid_risk['high'])
rule36 = ctrl.Rule(body_temp['very-high'] & heart_rate['high'] & spo2['critical'], covid_risk['Risk-Very-High'])

```

Figure 5.9: Defining the Fuzzy rules

The control system of fuzzy architecture is shown in the Figure 5.10.

```

# Create the control system
covid_ctrl = ctrl.ControlSystem([rule1, rule2, rule3, rule4, rule5, rule6, rule7, rule8, rule9, rule10,
rule11, rule12, rule13, rule14, rule15, rule16, rule17, rule18, rule19, rule20,
rule21, rule22, rule23, rule24, rule25, rule26, rule27, rule28, rule29, rule30,
rule31, rule32, rule33, rule34, rule35, rule36])

# Create the simulation
covid_simulation = ctrl.ControlSystemSimulation(covid_ctrl)

# Set the input values
covid_simulation.input['body_temp'] = 105
covid_simulation.input['heart_rate'] = 129
covid_simulation.input['spo2'] = 78

# Run the simulation
covid_simulation.compute()

# Print the output
print(covid_simulation.output['covid_risk'])

# Show the membership functions
body_temp.view()
heart_rate.view()
spo2.view()
covid_risk.view()
covid_risk.view(sim=covid_simulation)
plt.show(block=False)
plt.pause(30)
plt.close()

```

Figure 5.10: Fuzzy inference system

5.5 Defuzzification

Defuzzification is actually the conversion of the fuzzy value into a crisp/actual value. The value obtained after applying the fuzzy inference system and fuzzy rules is then de-fuzzify to get actual or crisp value. For defuzzification, we have chosen the weighted average method to obtain the COVID risk detection at the output. The defuzzification process determines the final COVID-19 detection result based on the fuzzy output.

Different methods to defuzzify the fuzzy output values are mentioned below.

5.5.1 Mean of maximum method (MOM)

This method calculate the average of fuzzy results that have the highest degrees. For example, the fuzzy result is : the temperature (x) is HIGH. So the mean of maximum method is expressed as;

$$\text{MOM (HIGH)} = \frac{\sum_{x \in T} x}{T} \quad T = \{x \mid \mu_{\text{HIGH}} = \text{Support } \mu_{\text{HIGH}}\} \quad (4.1)$$

T is the output set x that has the highest degree in the set HIGH.

5.5.2 Centre of Gravity (COG) method

This is also a defuzzification technique used to calculate the weighted average of the membership function of the area enclosed by the curve of the membership function.

If x is consider to be a continuous variable, then

$$\text{COG} = \frac{\int \mu(x) \times x \, dx}{\int \mu(x) \, dx} \quad (4.2)$$

If x is consider to be a discrete value, then

$$\text{COG} = \frac{\sum_x \mu(x) \times x}{\sum_x \mu(x)} \quad (4.3)$$

Where

$\mu(x)$ = Average value of membership function

x = Area of membership function

5.6 Conclusion

Fuzzy logic is used to detect the COVID-19 risk at the output depending on the specific design and rules describe in the fuzzy logic system. The result of the fuzzy logic system shows the COVID-19 risk level based on the fuzzy inputs and the defined rule base. The output is expressed as a linguistic term or a numerical value that indicates the degree of COVID-19 risk. The result determined is based on the combination of input variables (e.g., body temperature, blood oxygen level, heart rate) and their linguistic terms, along with the rule base that defines the relationships between these inputs and the COVID-19 risk.

This process is essential in assessing the COVID-19 risk for individuals in real-time. It provides a quantifiable measure of the risk level based on the available input data. This information can be utilized for further decision-making, such as determining the appropriate actions, interventions, or recommendations based on the assessed risk level.

CHAPTER 06

BUSINESS DESCRIPTION

6.1 Form of Business

Our business will be a private business.

6.1.1 Team/Organization Structure

Every business begins from a small scale and eventually starts to grow up. Similarly, we will start our company on a small scale by producing a fewer number of products but attempting to sell them within a specific time period. After some time our business will start to grow and will surely make a reasonable profit. The following are the positions that will be assigned to the members of the company:

Saif-Ur-Rehman will be the Possessor and Director of the company.

Muhammad Zayyad Abbasi will be the manager of company and marketing.

6.1.2 Vision

Our vision is to promote the smart patient health monitoring system for COVID-19 detection in Pakistan. To sort out this starving problem, an AI based patient health monitoring will be developed to monitor the COVID-19 risk by condition of a patient vital signs at real time. The real data achieved will be sending to the controller through wireless module to calculate the body temperature, heart rate and blood oxygen level.

6.1.3 Mission

The mission of the project is to

- ◆ Create an AI-based and comprehensive system that can monitor the health of patients and symptoms associated with COVID-19. Real time monitoring of patient vital parameters.
- ◆ Provide decision support to healthcare professionals for timely interventions.
- ◆ Real-time monitoring of patient health parameters.

6.1.4 Goals and objectives

The main goals and objectives of smart patient health monitoring system are

- ◆ Develop a health based monitoring system by using the vital parameters of human body such as temperature, heart rate, blood oxygen level (SpO₂).
- ◆ Bring smartness to the developed health monitoring system by integrating AI to the system through fuzzy logic technique for the early detection of COVID-19.

Here are the potential objectives of the smart patient health monitoring system. These are

Reduced exposure risk: Patient monitoring can reduce the exposure risk for healthcare workers as it reduces the need for frequent physical contact with the patient. This is particularly important during a pandemic when healthcare workers are at increased risk of infection.

Improved patient outcomes: A smart patient monitor that can detect COVID-19 can help monitor a patient's vital signs and alert healthcare providers of any changes in the patient's condition. This can help in timely intervention and potentially improve patient outcomes.

Efficient resource utilization: With a smart patient monitor, healthcare providers can monitor multiple patients remotely, which can help in efficient resource utilization.

6.2 Industry and Marketing Analysis

6.2.1 Industry Analysis

After the healthcare industrial visit, we came to know about the demand for advanced patient monitoring systems due to the COVID pandemic. The need for early detection and remote monitoring of patients has become crucial. No patient monitor has developed in Pakistan that can detect COVID-19 in the patients. So we took help from different sites from where we get information about our product. we came to observe that no industry is working on the development of intelligent patient monitor for COVID-19 detection.

In technological surveys, the technology industry plays a vital role in developing solutions for healthcare challenges. Smartness in the developed patient monitoring system can be brought by implementing the advanced AI and IoT techniques. Including Pakistan, no research has been made on the process of intelligent patient observation systems for Covid detection. So, by using advanced

analytics and AI algorithms in healthcare. These technologies can analyze large amounts of health data and provide valuable insights for the diagnosis and treatment of COVID detection.

6.2.2 Competitive analysis

As we have discussed that there is not much scope for this product in Pakistan but the developing countries such as Japan and American industries are very much in this market but we use the scamper technique to complete this product so we are at the top of the list. This experiment is not much done by our industries so we should avail of this opportunity and have to fulfill the requirements of the market. With continued growth, to serve the people and especially healthcare industries, the company will provide easy and cost-effective services to the companies of Pakistan and all others which are existing on the globe.

6.2.3 Purpose

Our purpose is to develop a patient monitoring system which addresses the following problems:

- ◆ Early detection and timely intervention of COVID-19
- ◆ Remote and real time monitoring
- ◆ Efficient resource utilization

6.3 SWOT Analysis

6.3.1 Strengths

- ◆ Advanced technological solution for early detection of COVID-19.
- ◆ Real-time data monitoring.
- ◆ Customized healthcare and individualized treatment approaches

6.3.2 Weaknesses

- ◆ High development and implementation cost.
- ◆ Dependency on reliable internet connectivity
- ◆ For user training for adaption of new technology

6.3.3 Opportunities

- ◆ Introduction of new technology will attract the people.
- ◆ The primary concern is to introduce modern ways in the field of especially healthcare systems.

- ◆ Industry 4.0 revolution

6.3.4 Threats

- ◆ Data security and privacy concerns.
- ◆ Competition from existing monitoring systems.
- ◆ Rapidly changing technological environment.

6.3.5 Marketing Flow

- ◆ Social media is very much affective, powerful and economical source of advertisement now a days.
- ◆ Electronic media (News Channel) is also very much attractive and convincing source to advertise our product.
- ◆ We will mainly target healthcare sectors, families for our project promotion.

6.4 Marketing Communication

In the next aspects of the public communications spectrum, the inherent strengths and shortcomings are taken into consideration and what they are incorporated, and how they are applied in this situation. By using social and electronic media which are nowadays considered as the most powerful and effective source of promotion and advertisement.

6.4.1 Advertising

It is an informal and sponsored means of educating the consumers through, radio, news media, online portals, etc. about their goods and services. Advertising is one of the most commonly used marketing tactics in which the information about the goods and services of the business can be effectively conveyed to the vast target audience.

6.4.2 Personal Selling

Marketing involves the selling of our project through videos and portals. Telling our customers how our system can fulfill their needs and how this bus can help them in making their work more easy, convenient, and more economical.

6.4.3 Direct Marketing

The efficacy of direct marketing can be directly calculated. Through inventing the technology, businesses use emails, faxes, and cell phones to connect with potential clients directly without including someone else.

6.5 Financial Plan

Following resources are required:

- ◆ To begin a business, all the basic resources must be required (i.e. Machinery, electronic equipment, a proper place etc.)
- ◆ Legal requirements
- ◆ Human resources
- ◆ Electricity (etc.)

Table 6.1: Initial Budget expenses

Sr. No	Capital Expenses	Amount (Rs.)
1	Laptop (40,000 x 1)	40,000.00
2	Equipment (18,000 x 1)	18,000.00
	Revenue Expenses	
3	Internet (4000 x12)	48000.00
4	Misc. Expenses (1500 x 12)	18000.00
5	Electricity (14,000 x 12)	168,000.00
6	Material Purchase (15,000 x 10)	150,000.00
	Total: initial Expenses	442,000.00

Table 6.2: Statement of Comprehensive Income

Sr. No		1st year	2nd year	3rd year	4th year	5th year
1	revenue	300,000/ -	315,000/-	330,000/-	380,000/-	430,000/-
2	Cost of production	60,000	80,000	130,000	170,000	200,000
3	Other operation expenses	100,000	100,000	104,000	110,000	140,000
4	depreciation	5,000	5,000	5,000	5,000	5,000
5	Misc.	4500	4500	4500	4500	4500
6	Marketing expenses	10000	16000	13000	15000	20000
7	Profit before commission	60,000/-	103,000/-	140,000/-	190000/-	270,000/-
s8	commission	15,000	20,200	25,000	52,100	109,300
9	Profit after commission	45,000/-	82,800/-	115,000/-	137,900/-	160,700/-

6.6 Notes

6.6.1 Note-1

All revenue and expenses are estimate.

6.6.2 Note-2

15% annually devaluation is provided to all non-current assets using the straight line method.

6.6.3 Note-3

10% commission will be paid on the basis of profit earned every year.

6.6.4 Note-4

As per “Income Tax Ordinance, 2001”, the income in all years is below than the minimum prescribed limit. So, no provision for tax is obligated.

6.6.5 Note-5

Raw material used in production consists of sensors i.e. body temperature, blood oxygen level, Esp-32, Wi-Fi controllers and other electrical components.

6.6.6 Note-6

Electricity is considered as a changing overhead price whose fluctuation is based on the factors such as production, number of unit generated over time.

6.6.7 Note-7

The all calculations are based on assumptions. So, there is a chance of imparity in these calculations.

6.7 Conclusion

In this chapter, the total business strategy is portrayed exhaustively alongside the five-year monetary arrangement. The undertaking's qualities and different highlights are additionally portrayed exhaustively. The design is to make it simple for the peruse to comprehend the financial worth and social remaining of this venture.

CHAPTER 07

CONCLUSION & FUTURE WORK

7.1 Conclusion

In this thesis, we are representing an AI-based smart health monitoring system that monitors infectious diseases, particularly in the context of a global pandemic like COVID-19, and gives us real-time data from our sensors. In the past few years, the world pandemic disease COVID-19 has caused a vast number of deaths and struck the way of living of many people. Fast and advance detection of Covid-19 is a very crucial task for the health-care community, but it is also critical in preventing the spread of the SARS- CoV- 2 virus. In recent years, Wireless technology and AI have grown in popularity to overcome the needs of various industries. Recently, Artificial intelligence has controlled the industrial organizations, especially in the areas of observation, high technology, and control systems. The technological advancements in the field of sensors, data acquisition, and artificial intelligence (AI) has given an opportunity for fast detection and diagnosis of COVID-19 through vital parameters such as body temperature, heart rate, and blood oxygen level.

Therefore, in this project, design and development of a smart health monitor capable of detecting COVID-19 disease has been done. Here, medical sensors have been used to acquire the vital signs of the patient and the data will be processed on the ESP-32 micro controller to display it on HDMI LCD. Moreover, the AI capability of Fuzzy Logic has been used to detect COVID-19 symptoms based on fuzzy rules. The fuzzy variables have been assigned to the vital signs and membership values have been given based on how closely a parameter is associated with the disease i.e., high fever is given high membership value, and moderate fever is given a lower degree of membership. Based on fuzzy rules and membership values, the defuzzification process provides the detection of COVID-19.

The aim of this project is split into three phases: simulation and logic construction, AI-based device development, and, eventually, implements the hardware. At the very first step simulation of sensors, control is presented on Proteus software. For simulation development, the Arduino controller is utilized here as a platform to sense the vital parameters such as body temperature, heart rate, and blood oxygen level through sensors and to control the vibrant scenario of the patient. Here, various sensors will be deployed to monitor the vital parameters of a patient. The gathered data will be

displayed on the dashboard and a GUI will also have designed to control the parameters of the patient monitor remotely. The system is designed to send data serially on the ThingSpeak Cloud and is shown as GUI. Meanwhile, the simulation is designed according to the parameters required for the detection of COVID-19. Furthermore, the Data was obtained in the form of CSV files. The mechanical development of the patient monitor includes the selection of sensors like BS18B20 and MAX30102, ESP-32 having Wi-Fi and Bluetooth capabilities.

The end comprises of implementation of the hardware and the discussion of the components used and the specifications of the components along with their experimental realization. In this project, we have proposed project an AI-based data system for the detection of COVID-19 and will not only acquire data but will also display it on a digital platform. The hardware implementation is done by interfacing ESP-32 with the Patient monitor using sensors and serially communicating with CloudSpeak where the server of the application access this real-time data and displays it on the dashboard.

7.2 Future Work

Future patient monitors will use sophisticated technologies such as advanced vital signs sensors, the Internet of Things, telemedicine and mobile health Blockchain technology, etc. These advanced devices and the technological system will improve accuracy, early detection, personalized care in the patient monitors and leading to better health results and enhancing patient well-being and will also allow patient monitors to be more profitable.

REFERENCES

- [1] M. Chen, Y. Hao, K. Hwang, L. Wang, and L. Wang, "Disease prediction by machine learning over big data from healthcare communities," *IEEE Access*, vol. 5, pp. 8869–8879, 2017.
- [2] Z. Zhiao, Chnaowei, and z. Nakdahira, "Healthcare application based on Internet of Things," in *Proc. IEEET Int.ConfE. on. Technology. Application. , Nov.2013*, pp. 661662.
- [3] Sujith, A. V. L. N. "Systematic review of smart health monitoring using deep learning and Artificial intelligence." *Neuroscience Informatics* 2.3 (2022): 100028.
- [4] S.S. Vedaiei, et al, A. Fotovvat, M.R. Mohebbian, G.M.E. Rahman, K.A. Wahid, P. Babyn, H.R. Marateb, M. Mansourian, R. Sami, COVID-SAFE: an IoT-based system for automated health monitoring and surveillance in post-pandemic life, *IEEE Access* 8 (2020) 188538–188551
- [5] Jeddi, Zineb, and Adam Bohr. "Remote patient monitoring using artificial intelligence." *Artificial Intelligence in Healthcare*. Academic Press, 2020. 203-234.
- [6] O. Taiwo, A.E. Ezugwu, Smart healthcare support for remote patient monitoring during Covid-19 quarantine, *Inform. Med. Unlock*. 20 (2020) 100428.
- [7] Briganti, Giovanni, and Olivier Le Moine. "Artificial intelligence in medicine: today and tomorrow." *Frontiers in medicine* 7 (2020): 27.
- [8] Li Hong-Tan, "Big data and ambient intelligence in IoT-based wireless student health monitoring system." *Aggression and Violent Behavior* (2021): 101601
- [9] T. Phan, and G. Chen, Some Applications of fuzzy Logic in Rule-Based Expert Systems, *Expert Systems*, vol.19, No.4, pp.208-223, 2018.
- [10] M. Jayalakshmi "Fuzzy logic-based health monitoring system for covid'19 patients." *Cmc-Computers Materials & Continua* (2021): 2430- 2446.
- [11] Mhlanga, David. "The role of artificial intelligence and machine learning amid the COVID-19 pandemic: What lessons are we learning on 4IR and the sustainable development goals." *International Journal of Environmental Research and Public Health* 19.3 (2022): 1879.
- [12] Jemal, Hanen, Zied Kechaou, and Mounir Ben Ayed. "Multi-agent based intuitionistic fuzzy logic healthcare decision support system." *Journal of Intelligent & Fuzzy Systems* 37.2 (2019): 2697-2712.

- [13] A. Rahaman , et al. Developing IoT based smart health monitoring systems: a review. *Rev d'Intell Artif.* 2019;33(6):435–40
- [14] L. A. Zadeh *et al*, “Fuzzy sets,” *Inf. Control*, vol. 8, no. 3, pp. 338–353, Jun. 2021.
- [15] N. H. Phuong and V. Kreinovich, "Fuzzy logic and its applications in medicine," *Int. J. Med. Informat.*, vol. 62, nos. 2–3, pp. 165–173, 2021.
- [16] M. Huang, Wearable thermometry for core body temperature measurement and its experimental verification. *IEEE J Biomed Health Inform.* 2019;21(3):708–14.
- [17] Albahri AS, et al. IoT-based telemedicine for disease prevention and health promotion: State-of-the-Art. *J Netw Comput Appl.* 2021;173:102873.
- [18] Hong-tan L, et al. Big data and ambient intelligence in IoT-based wireless student health monitoring system. *Aggress Violent Behav.* 2021. <https://doi.org/10.1016/j.avb.2021.101601>.
- [19] N. Sharma , et al. A smart ontology-based IoT framework for remote patient monitoring. *Biomed Signal Process Control.* 2021;68:102717.
- [20] N. Al Bassam. IoT-based wearable device to monitor the signs of quarantined remote patients of COVID-19. *Inform Med Unlocked.* 2021;24:100588.
- [21] AI. Paganelli, A conceptual IoT-based early-warning architecture for remote monitoring of COVID-19 patients in wards and at home. *Internet Things.* 2021. <https://doi.org/10.1016/j.iot.2021.100399>.
- [22] E. Moghadas, J Rezazadeh, A Farahbakhsh . An IoT patient monitoring based on fog computing and data mining: cardiac arrhythmia use case. *Internet Things.* 2020;11:100251.
- [23] <https://lastminuteengineers.com/ds18b20-arduino-tutorial/>
- [24] <https://lastminuteengineers.com/max30102-pulse-oximeter-heart-rate-sensor-arduino-tutorial/>
- [25] Mohamed A., Madkour, and Mohamed Roushdy. "Methodology for medical diagnosis based on fuzzy logic." *Egyptian Computer Science Journal* 26.1 (2022).